

Solid drilling and bore machining

- 1 HSS drilling
- 2 Solid carbide drilling
- 3 Indexable insert drilling
- 4 Reaming and Countersinking
- 5 Spindle Tooling

Threading

- 6 Taps and thread formers
- 7 Circular and Thread Milling
- 8 Thread turning

Turning

- 9 Turning Tools
- 10 Multifunctional Tools – EcoCut and FreeTurn
- 11 Grooving Tools
- 12 Miniature turning tools

Milling

- 13 HSS Milling Cutters
- 14 Solid Carbide milling cutters
- 15 Milling tools with indexable inserts

Clamping technology

- 16 Adaptors and Accessories
- 17 Workpiece clamping

- 18 Material examples

Table of contents

Symbol explanation	4
Toolfinder	5
List of contents	6+7
Product programme	8-31
Technical Information:	
Cutting Data	32-40
Formula for cutting data calculation	40
Version description	41
Differences between the milling cutter types	41
Coating	41

WNT \ Performance

Premium quality tools for high performance.

The premium quality tools from the **WNT Performance** product line have been designed for specific applications and are distinguished by their outstanding performance. If you make high demands on the performance of your production and want to achieve the very best results, we recommend the Premium tools in this product line.

Symbol explanation

Shank



Shank type



Length: extra short / short / medium / long / extra long

Cutting edge preparation



Sharp



Corner chamfer (CHW = chamfer width in mm)



Full Radius



Application



Machining example



The red arrows describe the possible feed directions



Cutting geometry
 $\lambda_s = 30^\circ$ = helix angle
 $\gamma_s = 12^\circ$ = rake angle

ZFP = Number of flutes

● = Main Application

○ = Extended application

Toolfinder

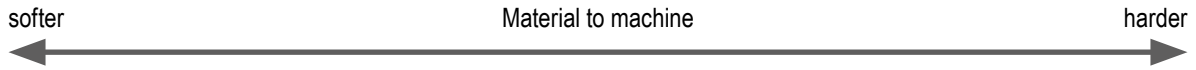

Finish milling

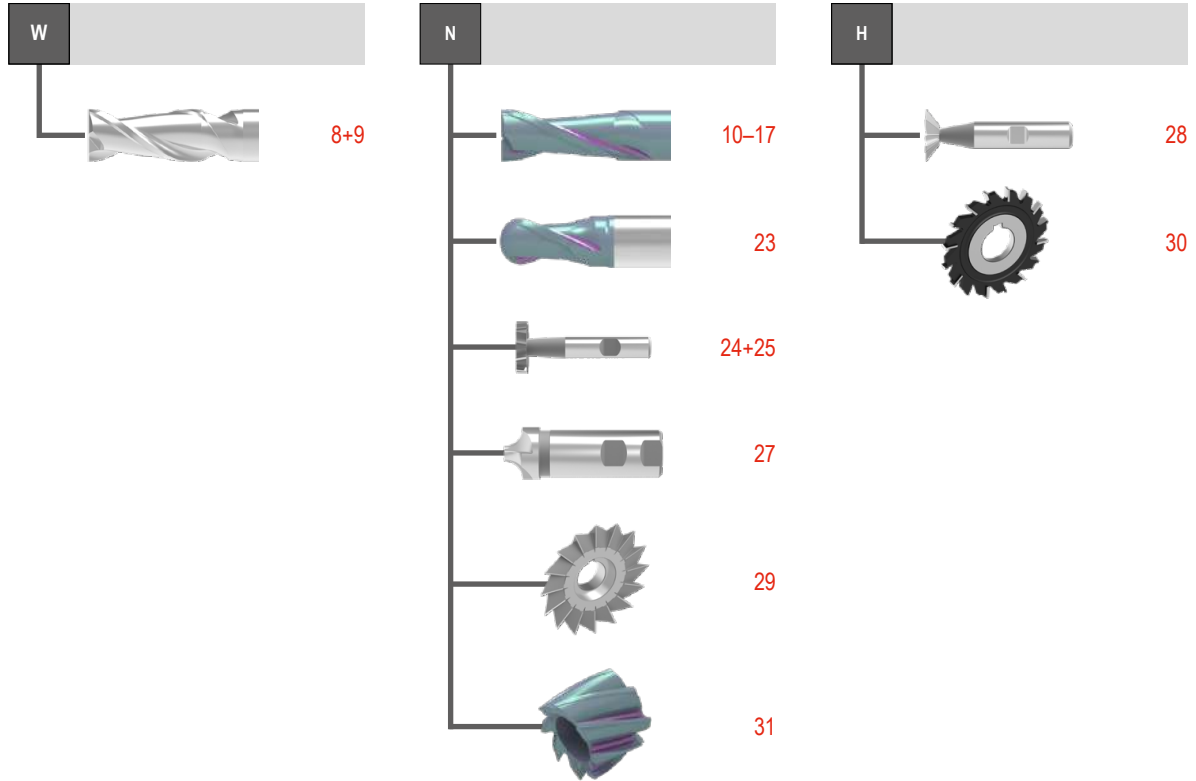

Rough and finish machining

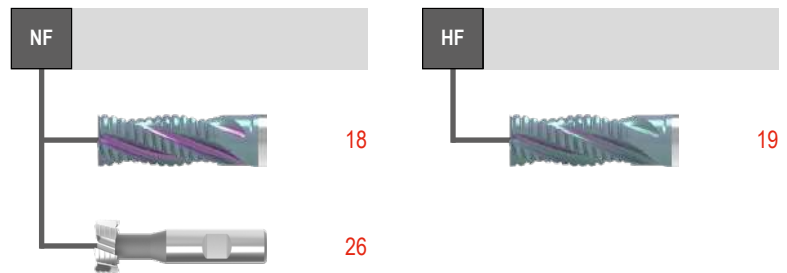

Rough machining

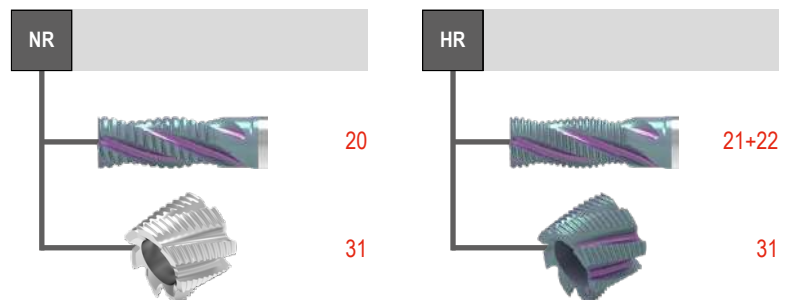

Overview HSS milling cutters

Tool type	ZEFP	Number of flutes	Diameter in mm	Material							Sharp	Corner chamfer	Corner radius	Full Radius	Length	Material, e.g. PM = Powdersteel	coated	uncoated	WNT \ Performance
				Steel	Stainless steel	Cast iron	Non-ferrous metals	Heat-resistant	Tempered steel	Non-metal materials									
Finishing cutter																			
	W	2	2-20	●	●	●	●	●	●	●	●	■					HSS-E	<input type="checkbox"/>	8
	W	3-4	2-32	●	●	●	●	●	●	●	●	■					HSS-E	<input type="checkbox"/>	9
	N	2	1-26	●	●	●	○	○	○	○	○	■					HSS-E	<input type="checkbox"/>	10+11
	N	3	1-10	●	●	●	○	○	○	○	○	■					HSS-E	<input type="checkbox"/>	12
	N	3	1,8-22,0	●	●	●	○	○	○	○	○	■					HSS-E	<input type="checkbox"/>	13+14
	N	4	4-20	○	○	○	●	●	●	●	●	■					HSS-E	<input type="checkbox"/>	15
	N	4-8	2-50	●	●	●	○	○	○	○	○	■					HSS-E	<input type="checkbox"/>	16+17
Rough and finish milling cutters																			
	NF	4	6-25	●	○	○	○	○	○	○	○	■					HSS-E	<input type="checkbox"/>	18
	HF	4	6-20	●	○	○	○	○	○	○	○	■					PM	<input type="checkbox"/>	19
Rough milling cutters																			
	NR	3	6-25	●	○	○	○	○	○	○	○	■	■				HSS-E	<input type="checkbox"/>	20
	HR	4-6	6-32	●	○	○	○	○	○	○	○	■	■				PM	<input type="checkbox"/>	21
	HR	3-6	4-32	●	○	○	○	○	○	○	○	■	■				HSS-E	<input type="checkbox"/>	22
Ball nose end milling cutters																			
	N	2	2-30	●	○	○	○	○	○	○	○	■		■		HSS-E	<input type="checkbox"/>	23	

Overview HSS milling cutters

Tool type	ZEFP	Number of flutes	Diameter in mm	Ø DC	Material							Form				Length	Material, e.g. PM = Powdersteel	coated	uncoated	Price
					P	M	K	N	S	H	O	Sharp	Corner chamfer	Corner radius	Full Radius					
	N	6-10	11-60		●	○	●	○	○	○	○	○					HSS-E	<input type="checkbox"/>	24	
	N	6-12	10,5-45,5		●	○	●	○	○	○	○	○					HSS-E	<input type="checkbox"/>	25	
	NF	6-8	21-45		●	○	●	○	○	○	○	○					HSS-E	<input type="checkbox"/>	26	
	N	4-6	6-16		●	○	●	○	○	○	○	○					HSS-E	<input type="checkbox"/>	27	
	H	10	16-25		●	○	●	○	○	○	○	○					HSS-E	<input type="checkbox"/>	28	
	N	14-28	40-125		●	○	●	○	○	○	○	○					HSS-E	<input type="checkbox"/>	29	
	H	16-48	50-160		●	○	●	○	○	○	○	○					HSS-E	<input type="checkbox"/>	30	
		7-10	40-80		●	○	●	○	○	○	○	○					HSS-E	<input type="checkbox"/>	<input type="checkbox"/>	31

Slot milling cutter HSS-E Co 8

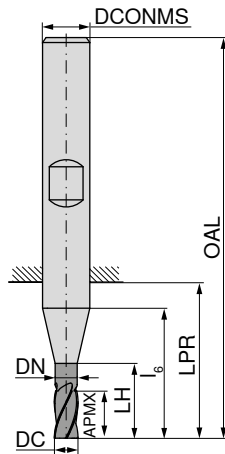
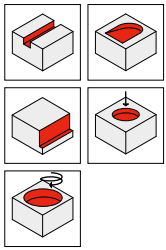
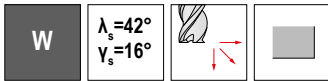

DIN 844



50 144 ...

DC _{e8} mm	APMX mm	DN mm	LH mm	l ₆ mm	LPR mm	OAL mm	DCONMS _{h6} mm	ZEFP
2.0	7		7	13	15	51	6	2
2.5	8		8	14	16	52	6	2
3.0	8		8	14	16	52	6	2
4.0	11		11	17	19	55	6	2
5.0	13		13	19	21	57	6	2
6.0	13		13	19	21	57	6	2
6.5	16	6.0	22	24	26	66	10	2
8.0	19	7.5	25	27	29	69	10	2
10.0	22	9.5	30	30	32	72	10	2
12.0	26	11.5	36	36	38	83	12	2
14.0	26	11.5	36	36	38	83	12	2
16.0	32	15.0	42	42	44	92	16	2
18.0	32	15.0	42	42	44	92	16	2
20.0	38	19.0	52	52	54	104	20	2

£	
U6	
35.29	020
33.66	025
32.85	030
33.66	040
34.52	050
34.52	060
46.87	065
39.65	080
48.17	100
55.39	120
64.24	140
70.66	160
89.87	180
110.32	200

P	
M	
K	
N	●
S	
H	
O	●

→ v_c/f_z Page 33-35

End milling cutter HSS-E Co 8

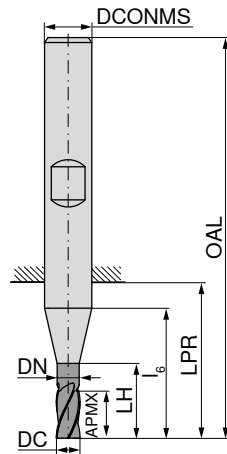
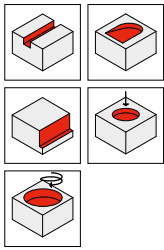
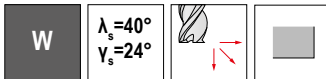

DIN 69844



DIN 844



DC _{k10} mm	APMX mm	DN mm	LH mm	l ₆ mm	LPR mm	OAL mm	DCONMS _{h6} mm	ZEFP
2	7		7	13	15	51	6	3
3	8		8	14	16	52	6	3
3	12		12	18	20	56	6	3
4	11		11	17	19	55	6	3
4	19		19	25	27	63	6	3
5	13		13	19	21	57	6	3
5	24		24	30	32	68	6	3
6	13	5.5	19	19	21	57	6	3
6	24	5.5	30	30	32	68	6	3
7	16	6.5	22	24	26	66	10	3
7	30	6.5	36	38	40	80	10	3
8	19	7.5	25	27	29	69	10	3
8	38	7.5	44	46	48	88	10	3
9	19	8.5	26	27	29	69	10	3
9	38	8.5	45	46	48	88	10	3
10	22	9.5	30	30	32	72	10	3
10	45	9.5	53	53	55	95	10	3
12	26	11.5	36	36	38	83	12	3
12	53	11.5	63	63	65	110	12	3
14	26	11.5	36	36	38	83	12	3
14	53	11.5	63	63	65	110	12	3
16	32	15.0	42	42	44	92	16	3
16	63	15.0	73	73	75	123	16	3
18	32	15.0	42	42	44	92	16	3
18	63	15.0	73	73	75	123	16	3
20	38	19.0	52	52	54	104	20	3
20	75	19.0	89	89	91	141	20	3
22	38	19.0	52	52	54	104	20	3
22	75	19.0	89	89	91	141	20	3
24	90	23.0	106	108	110	166	25	3
25	45	24.0	63	45	65	121	25	4
25	90	24.0	108	108	110	166	25	4
28	90	24.0	108	108	110	166	25	4
30	90	24.0	108	108	110	166	25	4
32	106	31.0	123	123	126	186	32	4

50 120 ...		50 121 ...	
£		£	
U8		U8	
42.55	020		
33.21	030	41.15	030
		40.89	040
34.27	050	40.89	050
		42.40	060
36.59	070	53.69	070
		45.62	080
39.31	080	61.06	090
		50.35	100
43.15	100	56.83	120
		65.10	140
48.17	120	66.06	160
		114.38	180
55.92	140		
		107.72	200
56.46	160	148.88	220
		204.77	240
93.21	180		
		194.25	250
91.87	200	235.20	280
126.93	220	279.66	300
		306.98	320
165.85	250		

P		
M		
K		
N	•	•
S		
H		
O	•	•

→ v_c/f_z Page 33-35

Slot milling cutter HSS-E Co 8

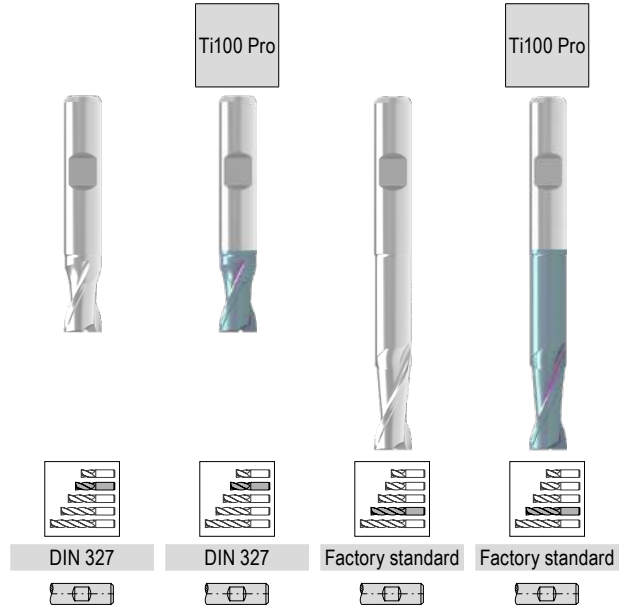
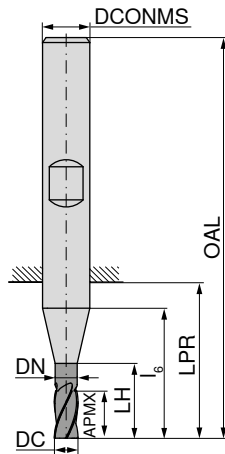
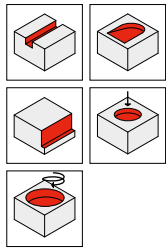
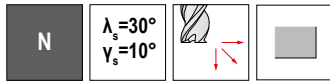

DC mm	DC Tol.	APMX mm	DN mm	LH mm	l ₆ mm	LPR mm	OAL mm	DCONMS _{h6} mm	ZEFP	50 100 ...		54 025 ...		50 122 ...		54 020 ...	
										£ U8	010 ¹⁾	£ U8	010 ¹⁾	£ U8	030	£ U8	030
1.0	h10	2.5		2.5	9	11	47	6	2	29.53	010 ¹⁾	29.17	010 ¹⁾				
1.5	h10	3.0		3.0	9	11	47	6	2	27.88	015 ¹⁾	28.04	015 ¹⁾				
1.8	h10	4.0		4.0	10	12	48	6	2	19.85	018	36.91	018				
2.0	e8	4.0		4.0	10	12	48	6	2	17.35	020	32.71	020				
2.5	e8	5.0		5.0	11	13	49	6	2	17.35	025	32.71	025				
3.0	e8	5.0		5.0	11	13	49	6	2	17.35	030	26.43	030				
3.0	e8	8.0		8.0	18	20	56	6	2					27.94	030	51.67	030
3.5	h10	6.0		6.0	12	14	50	6	2	17.35	035	24.72	035				
4.0	e8	7.0		7.0	13	15	51	6	2	17.35	040	22.40	040				
4.0	e8	11.0		11.0	25	27	63	6	2					29.32	040	34.81	040
4.5	h10	7.0		7.0	13	15	51	6	2	19.76	045	24.72	045				
5.0	e8	8.0		8.0	14	16	52	6	2	17.75	050	25.21	050				
5.0	e8	13.0		13.0	30	32	68	6	2					29.32	050	34.81	050
5.5	h10	8.0		8.0	14	16	52	6	2	19.76	055	26.34	055				
6.0	e8	8.0	5.50	14.0	14	16	52	6	2	17.75	060	24.85	060				
6.0	e8	13.0	5.50	30.0	30	32	68	6	2					31.28	060	36.54	060
6.5	h10	10.0	6.00	16.0	18	20	60	10	2	23.73	065	32.37	065				
7.0	e8	10.0	6.50	16.0	18	20	60	10	2	22.82	070	32.37	070				
7.0	e8	16.0	6.35	36.0	38	40	80	10	2					39.65	070	46.25	070
7.5	h10	10.0	7.00	16.0	18	20	60	10	2	24.63	075	32.47	075				
8.0	e8	11.0	7.50	17.0	19	21	61	10	2	23.18	080	34.57	080				
8.0	e8	19.0	7.35	44.0	46	48	88	10	2					34.61	080	43.43	080
8.5	h10	11.0	8.00	18.0	19	21	61	10	2	29.90	085	36.54	085				
9.0	h10	11.0	8.50	18.0	19	21	61	10	2	27.59	090	51.77	090				
9.0	h10	19.0	8.35	45.0	46	48	88	10	2					43.15	090	70.94	090
9.5	h10	11.0	9.00	18.0	19	21	61	10	2	29.49	095	52.84	095				
10.0	e8	13.0	9.50	21.0	21	23	63	10	2	28.67	100	34.33	100				
10.0	e8	22.0	9.35	53.0	53	55	95	10	2					37.95	100	45.98	100
10.5	h10	13.0	10.00	21.0	23	25	70	12	2	52.21	105	55.22	105				
11.0	h10	13.0	10.50	21.0	23	25	70	12	2	38.38	110	49.93	110				
11.0	h10	22.0	10.50	53.0	55	57	102	12	2					49.44	110	55.58	110
11.5	h10	13.0	11.00	21.0	23	25	70	12	2	53.25	115	56.10	115				
12.0	e8	16.0	11.50	26.0	26	28	73	12	2	35.51	120	44.91	120				
12.0	e8	26.0	11.50	63.0	63	65	110	12	2					43.06	120	52.76	120
13.0	h10	16.0	11.50	26.0	26	28	73	12	2	60.43	130	71.45	130				
14.0	e8	16.0	11.50	26.0	26	28	73	12	2	44.27	140	59.90	140				
14.0	e8	26.0	11.50	63.0	63	65	110	12	2					54.32	140	70.84	140
15.0	h10	16.0	11.50	26.0	26	28	73	12	2	56.10	150	66.43	150				
15.0	h10	26.0	11.50	63.0	63	65	110	12	2					68.25	150	117.73	150
16.0	e8	19.0	15.00	29.0	29	31	79	16	2	54.45	160	64.46	160				
16.0	e8	32.0	15.00	73.0	73	75	123	16	2					65.01	160	78.45	160

P	●	●	●	●
M	○	●	○	●
K	●	●	●	●
N	○	○	○	○
S	○	○	○	○
H				
O	○	○	○	○

1) Factory standard

Slot milling cutter HSS-E Co 8

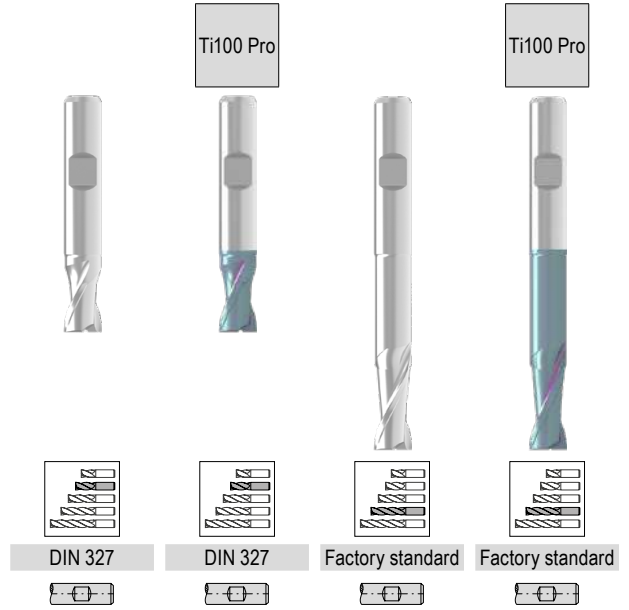
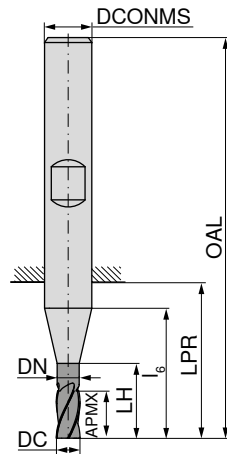
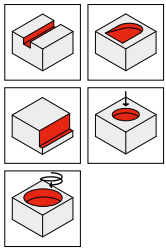
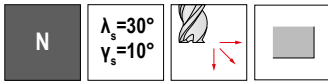

DC	DC Tol.	APMX	DN	LH	l ₆	LPR	OAL	DCONMS	h ₆	ZEFP	50 100 ...	54 025 ...	50 122 ...	54 020 ...
mm		mm	mm	mm	mm	mm	mm	mm			£	£	£	£
											U8	U8	U8	U8
17.0	h10	19.0	15.00	29.0	29	31	79	16	2		88.04	102.95		
18.0	e8	19.0	15.00	29.0	29	31	79	16	2		67.14	78.62		
18.0	e8	32.0	15.00	73.0	73	75	123	16	2				87.28	107.23
19.0	h10	19.0	15.00	29.0	29	31	79	16	2		103.85	109.96		
20.0	e8	22.0	19.00	36.0	36	38	88	20	2		78.06	94.71		
20.0	e8	38.0	19.00	89.0	89	91	141	20	2				85.58	109.06
22.0	e8	22.0	19.00	36.0	36	38	88	20	2		98.02	145.01		
24.0	e8	26.0	23.00	42.0	44	46	102	25	2		109.38	180.65		
25.0	e8	26.0	24.00	44.0	44	46	102	25	2		107.72	181.78		
26.0	h10	26.0	24.00	44.0	44	46	102	25	2		134.29	201.79		

P	●	●	●	●
M	○	●	○	●
K	●	●	●	●
N	○	○	○	○
S	○	○	○	○
H				
O	○	○	○	○

1) Factory standard

→ v_c/f_z Page 33-35

Throw-away milling cutter, HSS-E Co 8

▲ Shank similar to DIN 1835 B

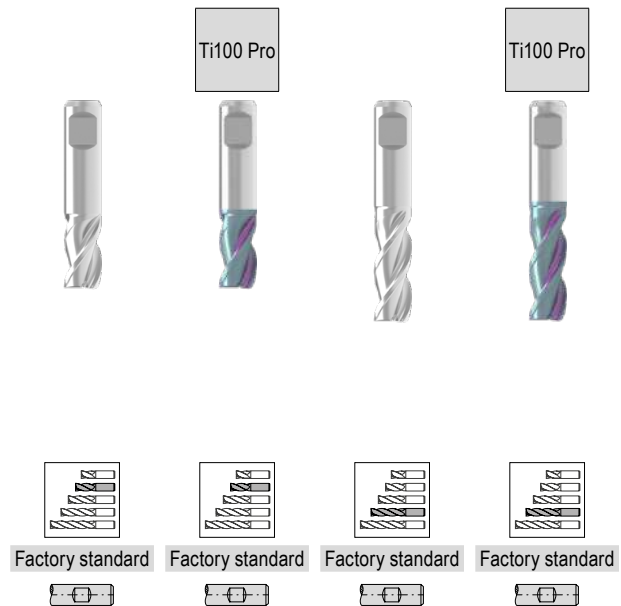
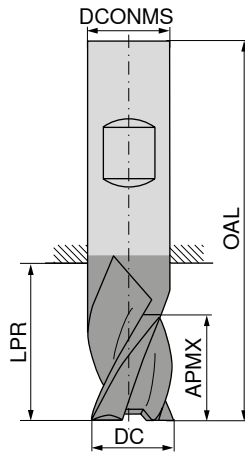
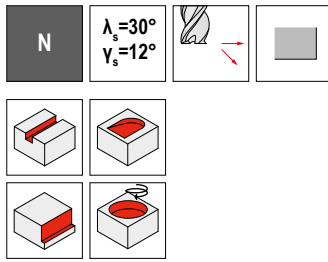

DC _{e8} mm	APMX mm	LPR mm	OAL mm	DCONMS _{h6} mm	ZEPF
1.00	2	8	34	6	3
1.50	3	8	34	6	3
1.50	4	10	35	6	3
1.80	3	8	34	6	3
2.00	4	9	35	6	3
2.00	7	12	38	6	3
2.30	4	9	35	6	3
2.50	5	10	36	6	3
2.50	8	13	39	6	3
2.80	5	10	36	6	3
3.00	5	10	36	6	3
3.00	8	13	39	6	3
3.30	6	11	37	6	3
3.50	6	11	37	6	3
3.50	10	15	41	6	3
3.80	7	12	38	6	3
4.00	7	12	38	6	3
4.00	11	16	42	6	3
4.30	7	12	38	6	3
4.50	7	12	38	6	3
4.50	11	16	42	6	3
4.80	8	13	39	6	3
5.00	8	13	39	6	3
5.00	13	18	44	6	3
5.30	8	13	39	6	3
5.50	8	13	39	6	3
5.50	13	18	44	6	3
5.75	8	13	39	6	3
6.00	8	13	39	6	3
6.00	13	18	44	6	3
6.50	10	14	42	8	3
6.50	16	20	48	8	3
7.00	10	14	42	8	3
7.00	16	20	48	8	3
7.50	10	14	42	8	3
7.50	16	20	48	8	3
8.00	11	15	43	8	3
8.00	19	23	51	8	3
8.50	11	16	48	10	3
8.50	19	24	56	10	3
9.00	11	16	48	10	3
9.00	19	24	56	10	3
9.50	11	16	48	10	3
9.50	19	24	56	10	3
10.00	13	18	50	10	3
10.00	22	27	59	10	3

50 092 ...		54 014 ...		50 093 ...		54 042 ...	
£		£		£		£	
U6	010	U8	010	U6	015 ¹⁾	U8	015 ¹⁾
15.37	015	19.76	015			21.85	
15.37		19.76		17.69		21.85	
15.37	018	19.76	018	17.69	020 ¹⁾	21.85	020
15.37	020	19.76	020			21.85	025
15.37		19.76		17.69	025 ¹⁾	21.85	
15.37	023	19.76	023	17.69	030 ¹⁾	21.85	030
15.37	025	19.76	025			21.85	035
15.37		19.76		17.69	035 ¹⁾	21.85	
15.37	028	19.76	028	17.69	040 ¹⁾	21.85	040
15.37	030	19.76	030			21.85	045
15.37		19.76		17.69	045 ¹⁾	21.85	
15.37	033	19.76	033	17.69	050 ¹⁾	21.85	050
15.37	035	19.76	035			21.85	055
15.37		19.76		17.69	055 ¹⁾	21.85	
15.37	038	19.76	038	17.69	060 ¹⁾	21.85	060
15.37	040	19.76	040			21.85	065
15.37		19.76		17.69	065 ¹⁾	21.85	
15.37	043	19.76	043	17.69	070 ¹⁾	21.85	070
15.37	045	19.76	045			21.85	075
15.37		19.76		17.69	075 ¹⁾	21.85	
15.37	048	19.76	048	17.69	080 ¹⁾	21.85	080
15.37	050	19.76	050			21.85	085
15.37		19.76		17.69	085 ¹⁾	21.85	
15.37	053	19.76	053	17.69	090 ¹⁾	21.85	090
15.37	055	19.76	055			21.85	095
15.37		19.76		17.69	095 ¹⁾	21.85	
15.37	057	19.76	057	17.69	100 ¹⁾	21.85	100
15.37	060	19.76	060			21.85	
15.37		19.76		17.69	100 ¹⁾	21.85	
17.80	065	26.04	065	21.22	065 ¹⁾	28.98	065
17.80		26.04		21.22	070 ¹⁾	28.98	070
17.80	070	26.04	070			28.98	075
17.80		26.04		21.22	075 ¹⁾	28.98	
17.80	075	26.04	075	21.22	080 ¹⁾	28.98	080
17.80	080	26.04	080			28.98	085
17.80		26.04		21.22	085 ¹⁾	28.98	
23.04	085	30.73	085	26.67	085 ¹⁾	32.87	085
23.04	090	30.73	090			32.87	090
23.04		30.73		26.67	090 ¹⁾	32.87	
23.04	095	30.73	095	26.67	095 ¹⁾	32.87	095
23.04	100	30.73	100			32.87	100
				26.67	100 ¹⁾	32.87	100

P	●	●	●	●
M	○	●	○	●
K	●	●	●	●
N	○	○	○	○
S	○	○	○	○
H				
O	○	○	○	○

1) Shank tolerance -0,025 / -0,0323

End milling cutter HSS-E Co 8

▲ ≤ Ø DC 6 mm, 3 cutting edges to centre

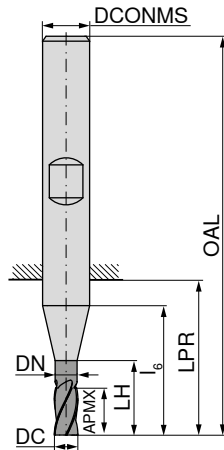
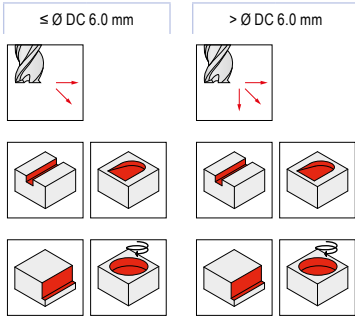
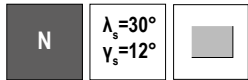

DC mm	DC Tol.	APMX mm	DN mm	LH mm	l ₆ mm	LPR mm	OAL mm	DCONMS _{h6} mm	ZEFP	54 021 ...		54 016 ...	
										£ U8		£ U8	
1.8	h10	4		4	10	12	48	6	3	31.73	018		
2.0	e8	4		4	10	12	48	6	3	28.16	020		
2.5	e8	5		5	11	13	49	6	3	28.16	025		
3.0	e8	5		5	11	13	49	6	3	28.16	030		
3.0	e8	8		8	14	16	52	6	3			34.07	030
3.5	h10	6		6	12	14	50	6	3	32.97	035		
3.5	h10	10		10	16	18	54	6	3			40.97	035
4.0	e8	7		7	13	15	51	6	3	28.16	040		
4.0	e8	11		11	17	19	55	6	3			25.34	040
4.5	h10	7		7	13	15	51	6	3	32.97	045		
4.5	h10	11		11	17	19	55	6	3			28.68	045
5.0	e8	8		8	14	16	52	6	3	28.16	050		
5.0	e8	13		13	19	21	57	6	3			25.34	050
5.5	h10	8		8	14	16	52	6	3	32.97	055		
5.5	h10	13		13	19	21	57	6	3			28.68	055
6.0	e8	8	5.5	14	14	16	52	6	3	28.16	060		
6.0	e8	13	5.5	19	19	21	57	6	3			25.34	060
6.5	h10	10	6.0	16	18	20	60	10	3	39.63	065		
6.5	h10	16	6.0	22	24	26	66	10	3			52.76	065
7.0	e8	10	6.5	16	18	20	60	10	3	43.56	070		
7.0	e8	16	6.5	22	24	26	66	10	3			52.76	070
7.5	h10	10	7.0	16	18	20	60	10	3	45.98	075		
7.5	h10	16	7.0	22	24	26	66	10	3			53.62	075
8.0	e8	11	7.5	17	19	21	61	10	3	43.15	080		
8.0	e8	19	7.5	25	27	29	69	10	3			36.06	080
8.5	h10	11	8.0	18	19	21	61	10	3	45.98	085		
8.5	h10	19	8.0	26	27	29	69	10	3			60.27	085
9.0	h10	11	8.5	18	19	21	61	10	3	45.98	090		
9.0	h10	19	8.5	26	27	29	69	10	3			51.90	090
9.5	h10	11	9.0	18	19	21	61	10	3	45.98	095		
9.5	h10	19	9.0	26	27	29	69	10	3			50.88	095
10.0	e8	13	9.5	21	21	23	63	10	3	43.06	100		
10.0	e8	22	9.5	30	30	32	72	10	3			37.27	100
10.5	h10	13	10.0	21	23	25	70	12	3	58.93	105		
11.0	h10	13	10.5	21	23	25	70	12	3	47.72	110		
11.0	h10	22	10.5	30	32	34	79	12	3			59.90	110
11.5	h10	13	11.0	21	23	25	70	12	3	58.93	115		
11.5	h10	22	11.0	30	32	34	79	12	3			71.70	115
12.0	e8	16	11.5	26	26	28	73	12	3	49.44	120		
12.0	e8	26	11.5	36	36	38	83	12	3			41.57	120

P	●	●
M	●	●
K	●	●
N	○	○
S	○	○
H		
O	○	○

End milling cutter HSS-E Co 8

▲ ≤ Ø DC 6 mm, 3 cutting edges to centre

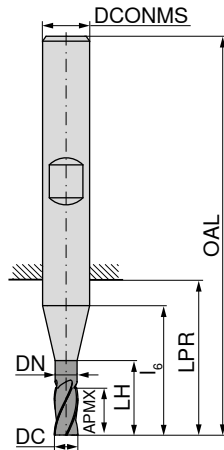
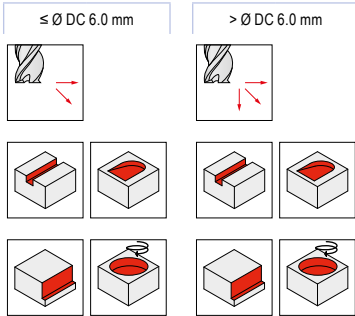
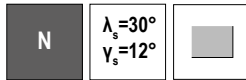

DC mm	DC Tol.	APMX mm	DN mm	LH mm	l ₆ mm	LPR mm	OAL mm	DCONMS _{h6} mm	ZEFP
13.0	h10	16	11.5	26	26	28	73	12	3
13.0	h10	26	11.5	36	36	38	83	12	3
14.0	e8	16	11.5	26	26	28	73	12	3
14.0	e8	26	11.5	36	36	38	83	12	3
15.0	h10	16	11.5	26	26	28	73	12	3
15.0	h10	26	11.5	36	36	38	83	12	3
15.5	h10	32	15.0	42	42	44	92	16	3
16.0	e8	19	15.0	29	29	31	79	16	3
16.0	e8	32	15.0	42	42	44	92	16	3
17.0	h10	19	15.0	29	29	31	79	16	3
17.0	h10	32	15.0	42	42	44	92	16	3
18.0	e8	19	15.0	29	29	31	79	16	3
18.0	e8	32	15.0	42	42	44	92	16	3
19.0	h10	19	15.0	29	29	31	79	16	3
19.0	h10	32	15.0	42	42	44	92	16	3
19.5	h10	38	19.0	52	52	54	104	20	3
20.0	e8	22	19.0	36	36	38	88	20	3
20.0	e8	38	19.0	52	52	54	104	20	3
22.0	e8	38	19.0	52	52	54	104	20	3

54 021 ...		54 016 ...	
£		£	
U8		U8	
66.66	130	83.26	130
60.15	140	50.69	140
78.84	150	86.72	150
		99.99	155
83.36	160	73.80	160
105.88	170	133.30	170
94.46	180	85.84	180
119.54	190	139.22	190
		156.95	195
109.96	200	89.41	200
		192.31	220

P	●	●
M	●	●
K	●	●
N	○	○
S	○	○
H		
O	○	○

→ v_c/f_z Page 33-35

End milling cutter HSS-E Co 8

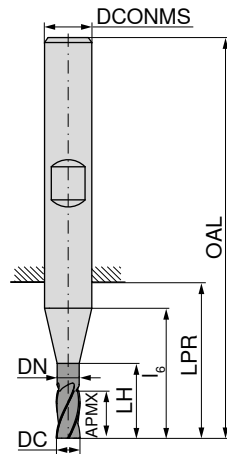
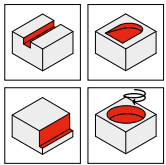
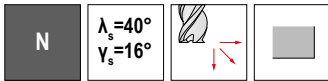

Ti100 Pro



Ti100 Pro



Factory standard



DIN 844



DIN 844



DC mm	DC Tol.	APMX mm	DN mm	LH mm	l ₆ mm	LPR mm	OAL mm	DCONMS _{h6} mm	ZEFP
4	k10	11		11	17	19	55	6	4
5	k10	13		13	19	21	57	6	4
6	e8	8	5.5	14	14	16	52	6	4
6	k10	13	5.5	19	19	21	57	6	4
8	e8	11	7.5	17	19	21	61	10	4
8	k10	19	7.5	25	27	29	69	10	4
10	e8	13	9.5	21	21	23	63	10	4
10	k10	22	9.5	30	30	32	72	10	4
12	e8	16	11.5	26	26	28	73	12	4
12	k10	26	11.5	36	36	38	83	12	4
14	e8	16	11.5	26	26	28	73	12	4
14	k10	26	11.5	36	36	38	83	12	4
15	k10	26	11.5	36	36	38	83	12	4
16	e8	19	15.0	29	29	31	79	16	4
16	k10	32	15.0	42	42	44	92	16	4
20	e8	22	19.0	36	36	38	88	20	4
20	k10	38	19.0	52	52	54	104	20	4

54 017 ...	50 124 ...	54 011 ...
£ U8	£ U8	£ U8
	37.47 040	47.17 040
	37.47 050	49.30 050
22.87 060	40.79 060	50.62 060
31.25 080	45.01 080	60.51 080
32.22 100	49.28 100	60.51 100
39.10 120	56.66 120	79.32 120
54.00 140	75.20 140	108.11 140
	81.36 150	
56.34 160	76.91 160	110.88 160
78.84 200	119.77 200	160.31 200

P	○	○	○
M	●	●	●
K	○	○	○
N	●	●	●
S	●	●	●
H			
O	●	●	●

→ v_c/f_z Page 33-35

End milling cutter HSS-E Co 8

▲ > Ø 28,0 mm recessed centre

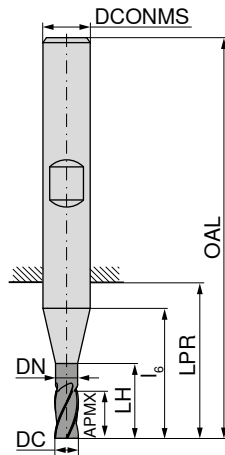
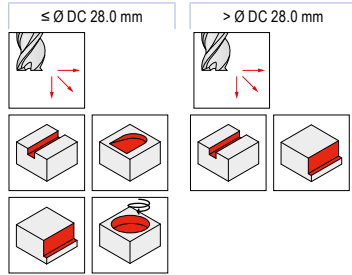
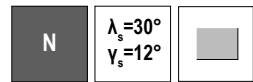

Ti100 Pro

Ti100 Pro

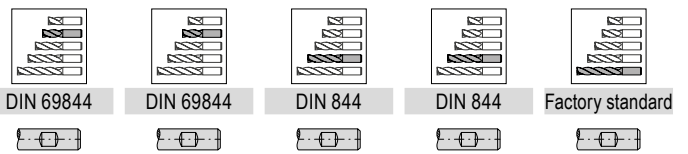

DC _{k10} mm	APMX mm	DN mm	LH mm	lg mm	LPR mm	OAL mm	DCONMS _{h6} mm	ZEFP	50 110 ...		54 018 ...		50 111 ...		54 019 ...		50 104 ...	
									£ U8	020	£ U8	020	£ U8	030	£ U8	030	£ U6	060
2.0	7		7	13	15	51	6	4	19.76	020	28.44	020						
2.5	8		8	14	16	52	6	4	19.76	025	28.44	025						
3.0	8		8	14	16	52	6	4	19.76	030	28.44	030						
3.0	12		12	18	20	56	6	4					32.67	030	37.65	030		
4.0	11		11	17	19	55	6	4	19.76	040	28.12	040						
4.0	19		19	25	27	63	6	4					33.57	040	38.13	040		
5.0	13		13	19	21	57	6	4	19.76	050	28.12	050						
5.0	24		24	30	32	68	6	4					29.49	050	38.13	050		
6.0	13	5.5	19	19	21	57	6	4	19.76	060	28.59	060						
6.0	24	5.5	30	30	32	68	6	4					29.49	060	35.66	060		
6.0	56	5.5	62	62	64	100	6	4									69.67	060
7.0	16	6.5	22	24	26	66	10	4	25.17	070	35.34	070						
8.0	19	7.5	25	27	29	69	10	4	24.42	080	39.62	080						
8.0	38	7.5	44	46	48	88	10	4					43.00	080	50.05	080		
8.0	70	7.5	73	73	75	115	10	4									82.68	080
9.0	19	8.5	26	27	29	69	10	4	27.52	090	47.61	090						
10.0	22	9.5	30	30	32	72	10	4	27.52	100	41.80	100						
10.0	45	9.5	53	53	55	95	10	4					43.00	100	53.51	100		
10.0	75	9.5	79	79	81	121	10	4									99.63	100
11.0	22	10.5	30	32	34	79	12	4	40.94	110	47.46	110						
12.0	26	11.5	36	36	38	83	12	4	37.82	120	45.56	120						
12.0	53	11.5	63	63	65	110	12	4					56.92	120	58.30	120		
12.0	85		85	85	85	130	12	4									108.11	120
13.0	26	11.5	36	36	38	83	12	4	53.69	130	65.03	130						
14.0	26	11.5	36	36	38	83	12	4	48.53	140	53.56	140						
14.0	53	11.5	63	63	65	110	12	4					65.54	140	69.01	140		
14.0	85		85	85	85	130	12	4									131.53	140
15.0	26	11.5	36	36	38	83	12	4	56.46	150	67.55	150						
15.0	53	11.5	63	63	65	110	12	4					59.25	150	93.93	150		
16.0	32	15.0	42	42	44	92	16	4	53.69	160	75.55	160						
16.0	63	15.0	73	73	75	123	16	4					79.61	160	93.57	160		
16.0	90	15.0	95	95	97	145	16	4									143.20	160
18.0	32	15.0	42	42	44	92	16	4	72.70	180	86.75	180						
18.0	63	15.0	73	73	75	123	16	4					97.51	180	112.78	180		
18.0	100	15.0	110	110	112	160	16	5									201.11	180
20.0	38	19.0	52	52	54	104	20	4	80.08	200	95.21	200						
20.0	75	19.0	89	89	91	141	20	4					95.01	200	126.93	200		
20.0	110	19.0	128	128	130	180	20	5									207.35	200

P	●	●	●	●	●
M	○	●	○	●	○
K	●	●	●	●	●
N	○	○	○	○	○
S	○	○	○	○	○
H					
O	○	○	○	○	○

End milling cutter HSS-E Co 8

▲ > Ø 28,0 mm recessed centre

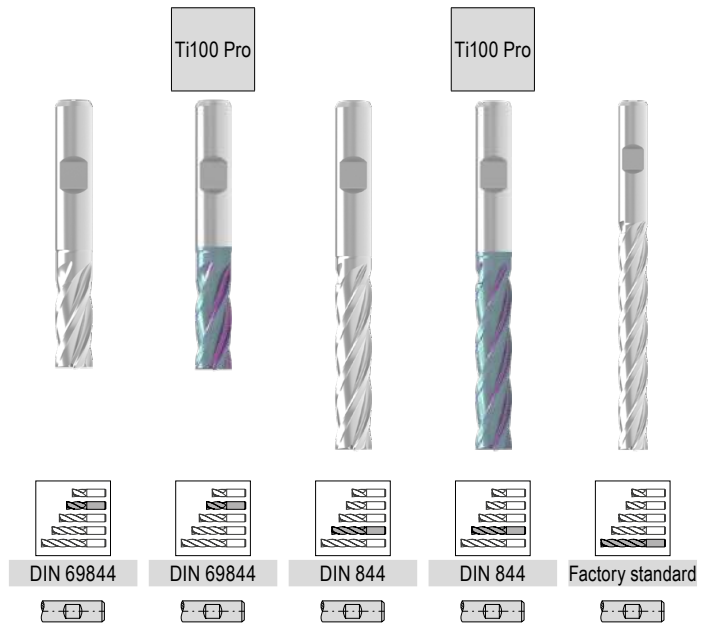
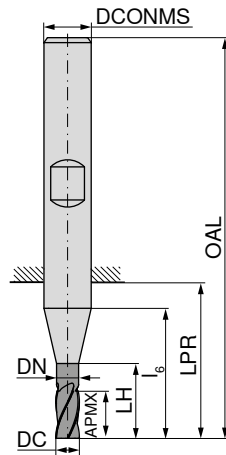
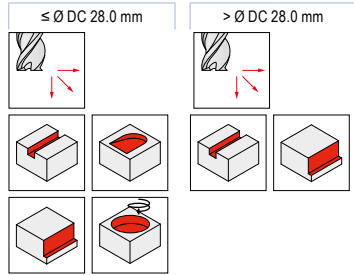
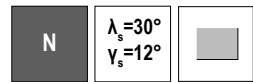

DC _{k10} mm	APMX mm	DN mm	LH mm	lg mm	LPR mm	OAL mm	DCONMS _{hg} mm	ZEFP	50 110 ...		54 018 ...		50 111 ...		54 019 ...		50 104 ...	
									£ U8	220	£ U8	220	£ U8	220	£ U8	220	£ U6	220
22.0	38	19.0	52	52	54	104	20	5	95.01	220	119.08	220						
22.0	75	19.0	89	89	91	141	20	5					124.36	220	182.63	220		
22.0	110	19.0	128	128	130	180	20	5									264.67	220
25.0	45	24.0	63	63	65	121	25	5	119.15	250	146.43	250						
25.0	90	24.0	108	108	110	166	25	5					155.69	250	254.46	250		
25.0	125	24.0	142	142	144	200	25	6									270.93	250
28.0	45	24.0	63	63	65	121	25	5	125.26	280	165.41	280						
28.0	90	24.0	108	108	110	166	25	5					193.18	280	300.94	280		
28.0	140	24.0	147	147	149	205	25	6									373.54	280
30.0	45	24.0	63	63	65	121	25	5	185.21	300	239.28	300						
30.0	90	24.0	108	108	110	166	25	5					216.19	300	329.70	300		
32.0	53	31.0	70	70	73	133	32	5										
32.0	53	31.0	70	70	73	133	32	6	185.21	320	189.95	320						
32.0	106	31.0	123	123	126	186	32	6					227.86	320	363.14	320		
32.0	160	31.0	167	167	170	230	32	6									450.85	320
40.0	63	38.0	80	80	85	155	40	6	309.03	400	375.01	400						
40.0	125	38.0	142	142	147	217	40	6					412.10	400	447.89	400		
40.0	180	31.0	197	197	200	260	32	8									758.50	400
50.0	150	48.0	172	172	172	252	50	8					991.21	500	957.38	500		
P										●	●	●	●	●	●	●	●	●
M										○	●	○	●	○	●	○	○	○
K										●	●	●	●	●	●	●	●	●
N										○	○	○	○	○	○	○	○	○
S										○	○	○	○	○	○	○	○	○
H																		
O										○	○	○	○	○	○	○	○	○

→ v_c/f_z Page 33-35

Roughing-finishing milling cutter HSS-E Co 5

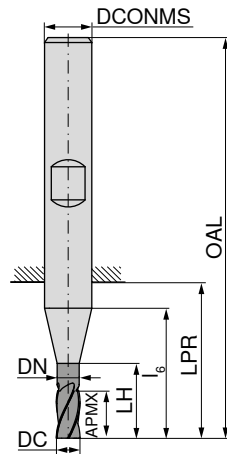
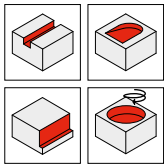
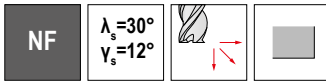

DC _{k12} mm	APMX mm	DN mm	LH mm	l ₆ mm	LPR mm	OAL mm	DCONMS _{h6} mm	ZEFP
6	13	5.5	19	19	21	57	6	4
6	24	5.5	30	30	32	68	6	4
7	16	6.5	22	24	26	66	10	4
8	19	7.5	25	27	29	69	10	4
8	38	7.5	44	46	48	88	10	4
9	19	8.5	26	27	29	69	10	4
10	22	9.5	30	30	32	72	10	4
10	45	9.5	53	53	55	95	10	4
11	22	10.5	30	32	32	79	12	4
11	45	10.5	53	55	57	102	12	4
12	26	11.5	36	36	38	83	12	4
12	53	11.5	63	63	65	110	12	4
13	26	11.5	36	36	38	83	12	4
14	26	11.5	36	36	38	83	12	4
16	32	15.0	42	42	44	92	16	4
16	63	15.0	73	73	75	123	16	4
18	32	15.0	42	42	44	92	16	4
20	38	19.0	52	52	54	104	20	4
20	75	19.0	89	89	91	141	20	4
22	38	19.0	52	52	54	104	20	4
22	75	19.0	89	89	91	141	20	4
25	45	24.0	63	63	65	121	25	4
25	90	24.0	108	108	110	166	25	4

	54 028 ...	54 029 ...
P	●	●
M	○	○
K	●	●
N	○	○
S	○	○
H		
O	○	○

£	060	070	080	090	100	110	120	130	140	160	180	200	220	250
U8														
41.92														
53.51														
51.29														
62.37														
58.44														
71.94														
65.21														
81.30														
74.42														
95.93														
118.81														
128.16														
159.24														
195.92														
59.30														
81.43														
85.25														
102.95														
92.99														
135.03														
177.06														
318.76														
345.31														

Powdersteel roughing finishing cutter

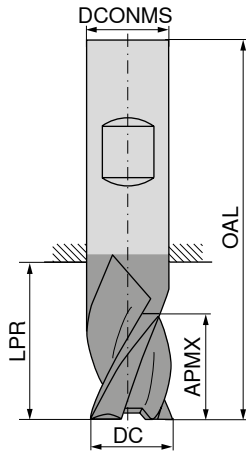
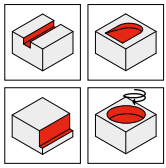
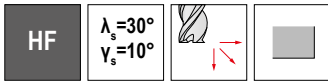

Ti100 Pro



DIN 844



54 034 ...

DC _{k12} mm	APMX mm	LPR mm	OAL mm	DCONMS _{h6} mm	ZFP
6	13	21	57	6	4
8	19	29	69	10	4
10	22	32	72	10	4
12	26	38	83	12	4
16	32	44	92	16	4
20	38	54	104	20	4

£	
U8	
49.04	060
66.82	080
69.58	100
76.85	120
116.09	160
146.95	200

P	●
M	○
K	●
N	○
S	○
H	○
O	○

→ v_c/f_z Page 33-35

Rough milling cutter HSS-E Co 8

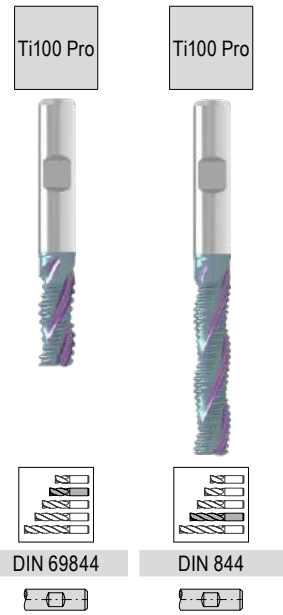
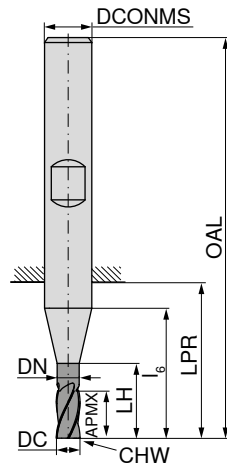
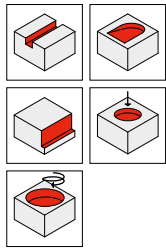

DC _{k12} mm	APMX mm	DN mm	LH mm	l ₆ mm	LPR mm	OAL mm	DCONMS _{h6} mm	CHW mm	ZEFP
6	13	5.5	19	19	21	57	6	0.5	3
6	24	5.5	30	30	32	68	6	0.5	3
8	19	7.5	25	27	29	69	10	0.7	3
8	38	7.5	44	46	48	88	10	0.7	3
10	22	9.5	30	30	32	72	10	0.7	3
10	45	9.5	53	53	55	95	10	0.7	3
12	26	11.5	36	36	38	83	12	0.7	3
12	53	11.5	63	63	65	110	12	0.7	3
14	26	11.5	36	36	38	83	12	0.9	3
14	53	11.5	63	63	65	110	12	0.9	3
16	32	15.0	42	42	44	92	16	0.9	3
16	63	15.0	73	73	75	123	16	0.9	3
18	32	15.0	42	42	44	92	16	0.9	3
18	63	15.0	73	73	75	123	16	0.9	3
20	38	19.0	52	52	54	104	20	0.9	3
20	75	19.0	89	89	91	141	20	0.9	3
25	45	24.0	63	63	65	121	25	0.9	3
25	90	24.0	108	108	110	166	25	0.9	3

	54 026 ...	54 027 ...
P	●	●
M	○	○
K	●	●
N	○	○
S	○	○
H		
O	○	○

	54 026 ...	54 027 ...		
£	U8	£	U8	
	50.80	060	61.25	060
	64.81	080	79.81	080
	65.55	100	83.88	100
	79.08	120	95.81	120
	84.00	140	107.96	140
	112.16	160	145.87	160
	128.91	180	159.75	180
	152.01	200	186.31	200
	221.48	250	284.48	250

→ v_c/f_z Page 33-35

Powdersteel Fine rough milling cutter

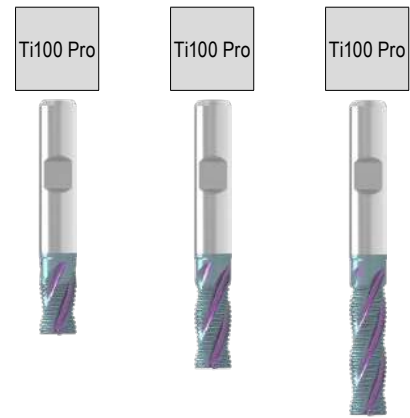
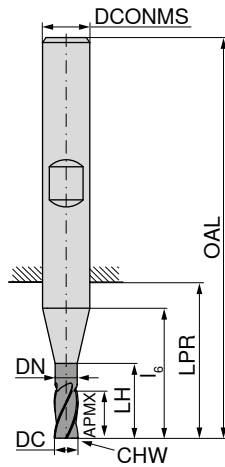
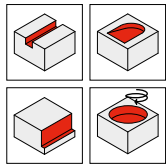
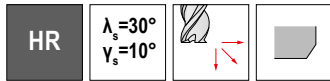

Factory standard

DIN 844

Factory standard



54 031 ...		54 032 ...		54 033 ...	
£		£		£	
U8	060	U8	060	U8	
62.10		45.56			
	080	61.74			
69.16				79.61	080
	100	64.24		98.02	100
70.23				116.25	120
	120	70.84			
83.95				147.46	140
	140	80.76			
107.66				189.62	160
	160	107.29			
116.09				239.17	180
	180	123.96			
140.87				288.55	200
	200	137.79			
156.79				361.83	220
	220	221.66			
211.89				422.59	250
	250	207.72			
247.98					
	320	292.52			
420.31					

DC _{k12} mm	APMX mm	DN mm	LH mm	l ₆ mm	LPR mm	OAL mm	DCONMS _{h6} mm	CHW mm	ZEFP
6	8	5.5	14	14	16	52	6	0.35	4
6	13	5.5	19	19	21	57	6	0.35	4
8	11	7.5	17	19	21	61	10	0.45	4
8	19	7.5	25	27	29	69	10	0.45	4
8	28	7.5	34	36	38	78	10	0.45	4
10	13	9.5	21	21	23	63	10	0.45	4
10	22	9.5	30	30	32	72	10	0.45	4
10	34	9.5	42	42	44	84	10	0.45	4
12	16	11.5	26	26	28	73	12	0.60	4
12	26	11.5	36	36	38	83	12	0.60	4
12	40	11.5	50	50	52	97	12	0.60	4
14	16	11.5	26	26	28	73	12	0.60	4
14	26	11.5	36	36	38	83	12	0.60	4
14	40	11.5	50	50	52	97	12	0.60	4
16	19	15.0	29	29	31	79	16	0.70	4
16	32	15.0	42	42	44	92	16	0.70	4
16	48	15.0	58	58	60	108	16	0.70	4
18	19	15.0	29	29	31	79	16	0.70	4
18	32	15.0	42	42	44	92	16	0.70	4
18	48	15.0	58	58	60	108	16	0.70	4
20	22	19.0	36	36	38	88	20	0.70	4
20	38	19.0	52	52	54	104	20	0.70	4
20	56	19.0	70	70	72	122	20	0.70	4
22	22	19.0	36	36	38	88	20	0.70	4
22	38	19.0	52	52	54	104	20	0.70	4
22	56	19.0	70	70	72	122	20	0.70	4
25	26	24.0	44	44	46	102	25	0.70	4
25	45	24.0	63	63	65	121	25	0.70	4
25	68	24.0	86	86	88	144	25	0.70	4
32	32	31.0	49	49	52	112	32	0.90	6
32	53	31.0	70	70	73	133	32	0.90	6

P	●	●	●
M	●	●	●
K	●	●	●
N	○	○	○
S	○	○	○
H			
O	○	○	○

→ v_c/f_z Page 33-35

Fine profile milling cutter HSS-E Co 8

▲ > Ø 28,0 mm recessed centre

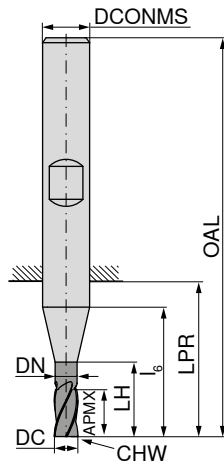
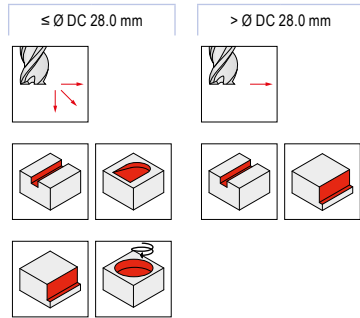
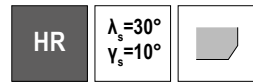

Factory standard



DIN 69844



DIN 844



DC _{k12} mm	APMX mm	DN mm	LH mm	l ₆ mm	LPR mm	OAL mm	DCONMS _{hg} mm	CHW mm	ZEFP
4	11		11	17	19	55	6	0.35	3
5	13		13	19	21	57	6	0.35	3
6	8	5.5	14	14	16	52	6	0.35	4
6	13	5.5	19	19	21	57	6	0.35	4
6	24	5.5	30	30	32	68	6	0.35	4
8	11	7.5	17	19	21	61	10	0.45	4
8	19	7.5	25	27	29	69	10	0.45	4
8	38	7.5	44	46	48	88	10	0.45	4
10	13	9.5	21	21	23	63	10	0.45	4
10	22	9.5	30	30	32	72	10	0.45	4
10	45	9.5	53	53	55	95	10	0.45	4
12	16	11.5	26	26	28	73	12	0.60	4
12	26	11.5	36	36	38	83	12	0.60	4
12	53	11.5	63	63	65	110	12	0.60	4
14	16	11.5	26	26	28	73	12	0.60	4
14	26	11.5	36	36	38	83	12	0.60	4
14	53	11.5	63	63	65	110	12	0.60	4
16	19	15.0	29	29	31	79	16	0.70	4
16	32	15.0	42	42	44	92	16	0.70	4
16	63	15.0	73	73	75	123	16	0.70	4
18	19	15.0	29	29	31	79	16	0.70	4
18	32	15.0	42	42	44	92	16	0.70	4
18	63	15.0	73	73	75	123	16	0.70	4
20	22	19.0	36	36	38	88	20	0.70	4
20	38	19.0	52	52	54	104	20	0.70	4
20	75	19.0	89	89	91	141	20	0.70	4
22	38	19.0	52	52	54	114	20	0.70	4
22	75	19.0	89	89	91	141	20	0.70	4
25	45	24.0	63	63	65	121	25	0.70	4
25	90	24.0	108	108	110	166	25	0.70	4
28	45	24.0	63	63	65	121	25	0.90	5
28	90	24.0	108	108	110	166	25	0.90	5
30	45	24.0	63	63	65	121	25	0.90	5
30	90	24.0	108	108	110	166	25	0.90	5
32	53	31.0	70	70	73	133	32	0.90	6
32	106	31.0	123	123	126	186	32	0.90	6

54 022 ...	54 023 ...	54 024 ...
£ U8	£ U8	£ U8
	58.12	040
	34.87	050
44.40	31.42	060
		60.08
52.02	38.03	080
		83.82
47.59	42.26	100
	46.81	120
56.83		95.93
	62.38	140
		125.76
76.99	67.71	160
		139.24
101.98	89.23	180
		164.34
103.67	93.78	200
	120.83	220
		225.35
	142.37	250
		359.57
	168.58	280
		402.76
	184.29	300
		420.58
	206.91	320
		424.81

P	●	●	●
M	●	●	●
K	●	●	●
N	○	○	○
S	○	○	○
H			
O	○	○	○

→ v_c/f_z Page 33-35

Ball nosed end milling cutter HSS-E Co 8

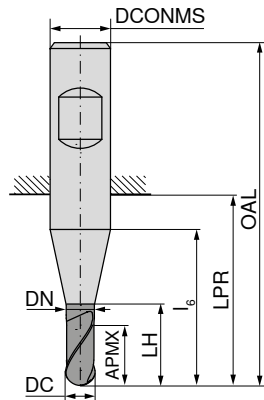
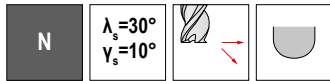

Ti100 Pro

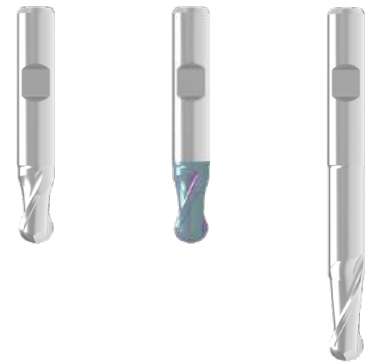

Factory standard

Factory standard

Factory standard



DC _{h10} mm	APMX mm	DN mm	LH mm	l ₆ mm	LPR mm	OAL mm	DCONMS _{h6} mm	ZEFP
2	4		4	10	12	48	6	2
3	5		5	11	13	49	6	2
3	8		8	18	20	56	6	2
4	7		7	13	15	51	6	2
4	11		11	25	27	63	6	2
5	8		8	14	16	52	6	2
5	13		13	30	32	68	6	2
6	8	5.50	14	14	16	52	6	2
6	13	5.50	30	30	32	68	6	2
7	10	6.50	16	18	20	60	10	2
7	16	6.35	36	38	40	80	10	2
8	11	7.50	17	19	21	61	10	2
8	19	7.35	44	46	48	88	10	2
9	11	8.50	18	19	21	61	10	2
9	19	8.35	45	46	48	88	10	2
10	13	9.50	21	21	23	63	10	2
10	22	9.35	53	53	55	95	10	2
11	13	10.50	21	23	25	70	12	2
11	22	10.50	53	55	57	102	12	2
12	16	11.50	26	26	28	73	12	2
12	26	11.50	63	63	65	110	12	2
13	16	11.50	26	26	28	73	12	2
14	16	11.50	26	26	28	73	12	2
14	26	11.50	63	63	65	110	12	2
15	16	11.50	26	26	28	73	12	2
15	26	11.50	63	63	65	110	12	2
16	19	15.50	29	29	31	79	16	2
16	32	15.00	73	73	75	123	16	2
18	19	15.50	29	29	31	79	16	2
18	32	15.00	73	73	75	123	16	2
20	22	19.00	36	36	38	88	20	2
22	22	19.00	36	36	38	88	20	2
24	26	23.00	42	44	46	102	25	2
24	45	23.00	106	108	110	166	25	2
25	26	24.00	44	44	46	102	25	2
25	45	24.00	108	108	110	166	25	2
26	26	24.00	44	44	46	102	25	2
28	26	24.00	44	44	46	102	25	2
30	26	24.00	44	44	46	102	25	2
30	45	24.00	108	108	110	166	25	2

50 320 ...		54 041 ...		50 321 ...	
£		£		£	
U8		U8		U8	
42.35	020	39.96	020		
40.23	030	38.52	030		
				46.87	030
40.23	040	38.52	040		
				46.87	040
40.23	050	38.52	050		
				48.18	050
39.88	060	38.38	060		
				49.28	060
49.44	070	73.25	070		
				58.50	070
44.12	080	68.07	080		
				54.07	080
52.37	090	78.77	090		
				60.81	090
50.28	100	50.88	100		
				60.81	100
58.67	110				
				67.72	110
56.57	120	58.56	120		
				68.80	120
68.16	130	105.32	130		
65.54	140	75.15	140		
				81.75	140
77.15	150	124.91	150		
				103.53	150
80.30	160	127.85	160		
				103.53	160
99.63	180	111.04	180		
				129.86	180
106.29	201	115.62	201		
145.10	220				
138.82	240	230.96	240		
				195.56	240
138.82	250				
				183.38	250
190.29	260				
190.44	280				
208.06	300				
				264.90	300

P	●	●	●
M	○	○	○
K	●	●	●
N	○	○	○
S	○	○	○
H			
O	○	○	○

T-slot milling cutter HSS-E Co 5, cross pitched

▲ For slots according to DIN 650

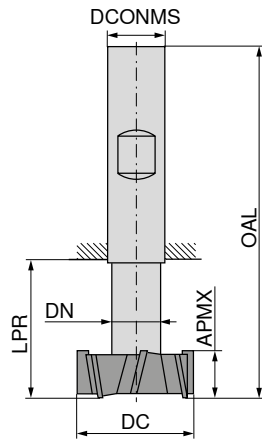
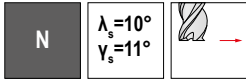

DIN 851 A



50 240 ...

DC _{d11} mm	APMX _{d11} mm	DN _{h12} mm	LPR mm	OAL mm	DCONMS _{h6} mm	ZEFP	£ U6	
11.0	4	4	13.5	53.5	10	6	111.79	110
12.5	6	5	17.0	57.0	10	6	109.01	125
16.0	8	7	22.0	62.0	10	6	123.43	160
18.0	8	8	25.0	70.0	12	6	140.25	180
19.0	9	8	26.0	71.0	12	6	178.78	190 ¹⁾
21.0	9	10	29.0	74.0	12	6	160.51	210
22.0	10	10	30.0	75.0	12	6	208.81	220 ¹⁾
25.0	11	12	34.0	82.0	16	8	188.71	250
28.0	12	13	37.0	85.0	16	8	254.56	280 ¹⁾
32.0	14	15	42.0	90.0	16	8	271.17	320
36.0	16	17	47.0	103.0	25	8	413.57	360 ¹⁾
40.0	18	19	52.0	108.0	25	10	552.70	400
45.0	20	21	57.0	113.0	25	10	588.26	450 ¹⁾
50.0	22	25	64.0	124.0	32	10	706.43	500
60.0	28	30	79.0	139.0	32	10	923.26	600

P	●
M	○
K	●
N	○
S	○
H	
O	○

1) Factory standard

Slot milling cutter HSS-E Co 5, cross-pitched

▲ For slots according to DIN 6888

▲ $CDX = a_{p\max}$

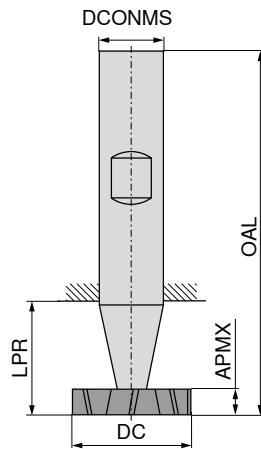
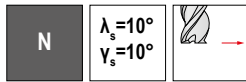

DIN 850



50 234 ...

DC _{h12} mm	APMX _{e8} mm	LPR mm	OAL mm	DCONMS _{h6} mm	CDX mm	ZEFP	£	
10.5	2.0	14	50	6	3.25	6	83.95	100
10.5	2.5	14	50	6	3.15	6	83.95	101
10.5	3.0	14	50	6	3.15	6	83.95	102
13.5	2.0	16	56	10	4.45	6	83.88	130 ¹⁾
13.5	3.0	16	56	10	4.45	6	83.88	132
13.5	4.0	16	56	10	4.45	6	83.88	133
16.5	3.0	16	56	10	5.95	6	91.01	161
16.5	4.0	16	56	10	5.95	6	91.01	162
16.5	5.0	16	56	10	5.75	6	91.01	163
19.5	3.0	23	63	10	6.95	8	101.09	190 ¹⁾
19.5	4.0	23	63	10	6.95	8	101.09	191
19.5	5.0	23	63	10	6.75	8	101.09	192
22.5	4.0	23	63	10	8.25	8	119.26	220 ¹⁾
22.5	5.0	23	63	10	8.25	8	119.26	221
22.5	6.0	23	63	10	8.00	8	119.26	222
25.5	5.0	23	63	10	9.00	10	124.36	250 ¹⁾
25.5	6.0	23	63	10	9.00	10	124.36	251
28.5	6.0	23	63	10	10.00	10	173.28	281
28.5	8.0	23	63	10	10.00	10	173.28	283
32.5	6.0	26	71	12	12.00	10	176.83	321 ¹⁾
32.5	8.0	26	71	12	12.00	10	176.83	322
38.5	8.0	26	71	12	13.35	10	256.61	381 ¹⁾
45.5	10.0	26	71	12	16.85	12	313.47	450

P	●
M	○
K	●
N	○
S	○
H	
O	○

1) Factory standard

→ v_c/f_z Page 36

T-slot milling cutter HSS-E Co 5

▲ For slots according to DIN 650

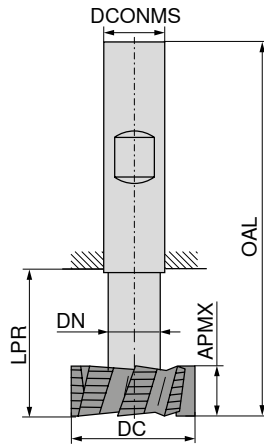
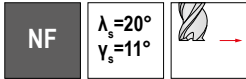

DIN 851 A



50 241 ...

DC _{d11} mm	APMX mm	DN _{h12} mm	LPR mm	OAL mm	DCONMS _{h6} mm	ZEFP	£ U6	
21	9	10	29	74	12	6	233.86	210
22	10	10	30	75	12	6	276.02	220 ¹⁾
25	11	12	34	82	16	6	280.03	250
28	12	13	37	85	16	6	299.60	280 ¹⁾
32	14	15	42	90	16	6	387.01	320
36	16	17	47	103	25	6	478.57	360 ¹⁾
40	18	19	52	108	25	8	581.80	400
45	20	21	57	113	25	8	701.86	450 ¹⁾

P	●
M	○
K	●
N	○
S	○
H	
O	○

1) Factory standard

Quarter-round profile milling cutter HSS-E Co 5, concave

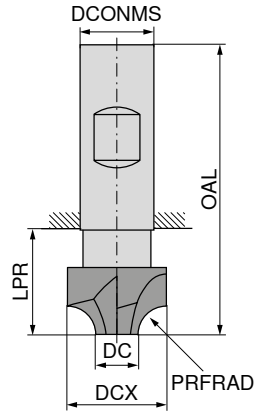
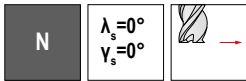

50 248 ...

PRFRAD _{H11} mm	DCX mm	DC mm	LPR mm	OAL mm	DCONMS _{H6} mm	ZEFP	£	
1.0	8	6	20	60	10	4	94.35	010
1.5	9	6	20	60	10	4	99.06	015
2.0	10	6	20	60	10	4	94.35	020
2.5	11	6	20	60	10	4	99.06	025
3.0	12	6	15	60	12	4	99.06	030
4.0	14	6	15	60	12	4	106.24	040
5.0	16	6	15	60	12	4	126.01	050
6.0	20	8	19	67	16	4	146.85	060
8.0	24	8	23	71	16	4	173.37	080
9.0	26	8	29	85	25	4	241.22	090
10.0	28	8	29	85	25	4	219.17	100
12.0	34	10	34	90	25	4	314.13	120
15.0	46	16	44	100	25	6	586.06	150
16.0	48	16	44	100	25	6	615.36	160

P	●
M	○
K	●
N	○
S	○
H	
O	○

→ v_c/f_z Page 36

Single angle milling cutters HSS-E Co 5

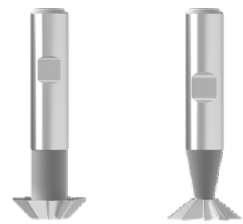
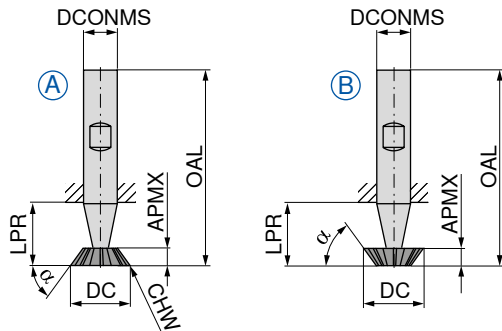
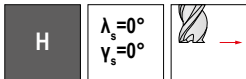

α°	DC mm	APMX mm	LPR mm	OAL mm	DCONMS _{h6} mm	CHW mm	ZEFP	Fig.	DIN 1833	
									50 246 ...	50 245 ...
45	16	4.0	15	60	12	0.3	10	A	£ U6	
	16	4.0	15	60	12		10	B	106.89	016
	20	5.0	18	63	12	0.3	10	A		
	20	5.0	18	63	12		10	B	140.79	020
	25	6.3	22	67	12	0.3	10	A		
	25	6.3	22	67	12		10	B	167.39	025
60	16	6.3	15	60	12	0.3	10	A		
	16	6.3	15	60	12		10	B	106.89	116
	20	8.0	18	63	12	0.3	10	A		
	20	8.0	18	63	12		10	B	140.79	120
	25	10.0	22	67	12	0.3	10	A		
	25	10.0	22	67	12		10	B	167.39	125
70	16	7.0	15	60	12	0.3	10	A		142.30 216 ¹⁾
	20	9.0	18	63	12	0.3	10	A		179.19 220 ¹⁾
	25	11.0	19	67	16	0.3	10	A		239.47 225 ¹⁾
P									●	●
M									○	○
K									●	●
N									○	○
S									○	○
H										
O									○	○

1) Factory standard

Double angle milling cutter HSS

▲ with keyway to DIN 138

N	$\lambda_s=0^\circ$
	$\gamma_s=0^\circ$

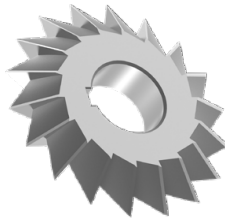
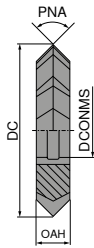

Shell type single angle milling cutter HSS

▲ with keyway to DIN 138

N	$\lambda_s=0^\circ$
	$\gamma_s=2^\circ$

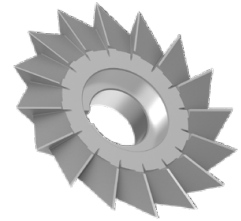
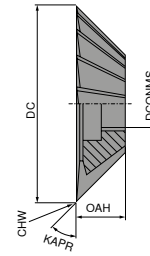

DIN 847

50 360 ...

PNA °	DC mm	OAH mm	DCONMS mm	ZEFP	£ U6	
45	50	8	16	22	176.64	045
	63	10	22	24	220.30	145
	80	12	27	26	340.26	245
	100	18	32	28	509.77	345
60	50	10	16	18	176.64	060
	63	14	22	20	245.53	160
	80	18	27	22	394.87	260
	100	25	32	24	632.65	360
90	50	14	16	16	209.49	090
	63	20	22	18	267.08	190
	80	22	27	20	434.62	290
	100	32	32	24	726.26	390
120	50	14	16	16	236.32	120 ¹⁾
	63	20	22	16	335.77	121 ¹⁾

P	●
M	○
K	●
N	○
S	○
H	○
O	○

1) Factory standard

→ v_c/f_z Page 37

DIN 842 A

50 362 ...

KAPR °	DC mm	OAH mm	DCONMS mm	CHW mm	ZEFP	£ U6	
45	40	10	10	0.3	14	197.39	045
	50	13	13	0.3	16	271.35	145
	63	18	16	0.3	18	343.06	245
	80	22	22	0.3	20	484.49	345
	100	28	27	0.3	22	731.59	445
50	50	16	13	0.3	16	271.35	150
60	40	13	10	0.3	14	176.83	060
	50	16	13	0.3	16	217.21	160
	63	20	16	0.3	18	303.81	260
	80	25	22	0.3	20	487.41	360
	100	32	27	0.3	22	742.50	460
	125	40	32	0.3	28	1,250.85	560

P	●
M	○
K	●
N	○
S	○
H	○
O	○

→ v_c/f_z Page 37

Side and face milling cutter HSS-E Co 5

- ▲ Fine cross-pitched version
- ▲ with keyway to DIN 138

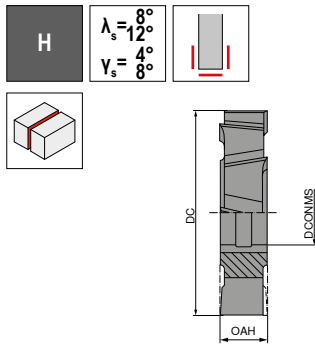

DIN 885 A

50 349 ...

DC _{js16} mm	OAH _{k11} mm	DCONMS _{H7} mm	ZEPF	£ U6	
50	4	16	16	221.71	100
50	5	16	16	223.15	102
50	6	16	16	234.72	104
50	8	16	16	252.28	106
50	10	16	16	276.16	108
63	4	22	18	242.82	200
63	5	22	18	260.91	202
63	6	22	18	250.35	204
63	8	22	18	280.73	206
63	10	22	18	313.23	208
63	12	22	18	355.77	210
63	14	22	18	399.52	212
80	5	27	20	327.83	300
80	6	27	20	338.71	302
80	8	27	20	352.59	304
80	10	27	18	361.38	306
80	12	27	18	407.08	308
80	14	27	18	470.13	310
80	16	27	18	509.64	312
80	18	27	18	587.50	314
80	20	27	18	587.84	316
100	6	32	22	472.93	400
100	8	32	22	469.94	402
100	10	32	20	507.40	404
100	12	32	20	547.27	406
100	14	32	20	610.30	408
100	16	32	20	643.69	410
100	18	32	20	756.32	412
100	20	32	20	761.41	414
100	25	32	20	942.34	418
125	8	32	24	627.89	500
125	10	32	22	673.22	502
125	12	32	22	724.15	504
125	14	32	22	816.20	506
125	16	32	22	846.09	508
125	18	32	22	974.66	510
125	20	32	22	994.70	512
125	25	32	22	1,190.95	516
160	10	40	26	1,001.39	600
160	12	40	26	1,090.27	602
160	14	40	26	1,170.76	604
160	16	40	26	1,259.46	606
160	18	40	26	1,382.95	608
160	20	40	26	1,384.37	610
160	25	40	26	1,728.33	614
160	32	40	26	2,172.46	618

P	●
M	○
K	●
N	●
S	○
H	
O	●

→ v_c/f_z Page 38

Narrow side and face milling cutter HSS-E Co 5

- ▲ Fine cross-pitched version
- ▲ with keyway to DIN 138

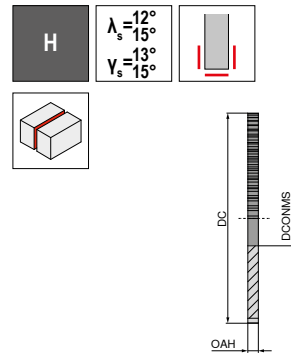

DIN 1834 A

50 340 ...

DC _{js16} mm	OAH _{k11} mm	DCONMS _{H7} mm	ZEPF	£ U6	
63	1.6	22	28	168.43	200
63	2.0	22	28	165.68	202
63	2.5	22	28	169.21	204
63	3.0	22	28	173.92	206
80	1.6	27	32	200.12	300
80	2.0	27	32	194.31	302
80	2.5	27	32	197.65	304
80	3.0	27	32	203.27	306
80	4.0	27	32	217.48	310
100	1.6	32	36	239.29	400
100	2.0	32	36	237.90	402
100	2.5	32	36	237.90	404
100	3.0	32	36	242.09	406
100	4.0	32	36	260.91	410
100	5.0	32	36	286.37	414
125	1.6	32	40	313.42	500
125	2.0	32	40	301.31	502
125	2.5	32	40	310.33	504
125	3.0	32	40	316.40	506
125	4.0	32	40	338.90	510
125	5.0	32	40	362.97	514
125	6.0	32	40	350.89	516
160	2.0	40	48	502.29	600
160	2.5	40	48	483.67	602
160	3.0	40	48	492.79	604
160	4.0	40	48	520.91	606
160	5.0	40	48	551.47	608
160	6.0	40	48	592.07	610
160	8.0	40	36	675.85	612

P	●
M	
K	●
N	●
S	●
H	
O	●

→ v_c/f_z Page 38

Face milling cutters HSS-E Co 5

▲ with keyway to DIN 138

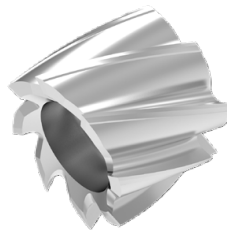
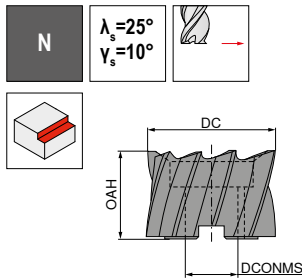

DIN 1880

50 250 ...

DC _{k10} mm	OAH mm	DCONMS mm	ZEFP	£ U8	
40	32	16	8	192.42	040
50	36	22	8	246.65	050
63	40	27	8	350.48	063
80	45	27	10	514.12	080

P	●
M	●
K	●
N	●
S	○
H	●
O	●

→ v_c/f_z Page 39+40

Roughing face milling cutters HSS-E Co 5

▲ with keyway to DIN 138

▲ Manufacturing tolerance lies on the plus range of the tolerance js14

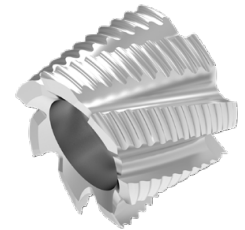
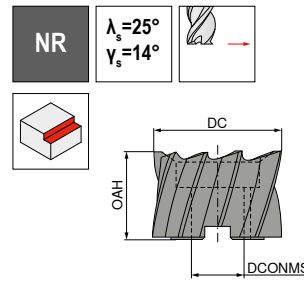

DIN 1880

50 260 ...

DC _{js14} mm	OAH mm	DCONMS mm	ZEFP	£ U8	
40	32	16	7	196.06	040
50	36	22	8	260.01	050
63	40	27	8	348.04	063
80	45	27	10	480.67	080

P	●
M	●
K	●
N	●
S	○
H	●
O	●

→ v_c/f_z Page 39+40

Face milling cutters HSS-E Co 5

▲ with keyway to DIN 138

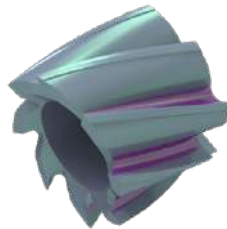
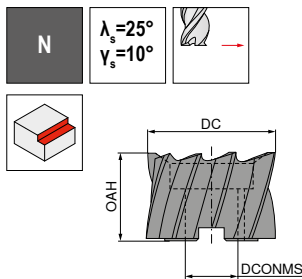

Ti100 Pro

DIN 1880

54 035 ...

DC _{k10} mm	OAH mm	DCONMS mm	ZEFP	£ U8	
40	32	16	8	282.45	040
50	36	22	8	346.43	050
63	40	27	8	319.28	063
80	45	27	10	496.34	080

P	●
M	●
K	●
N	●
S	○
H	●
O	●

→ v_c/f_z Page 39+40

Roughing-finishing face milling cutters HSS-E Co 8

▲ with keyway to DIN 138

▲ Manufacturing tolerance lies on the plus range of the tolerance js14

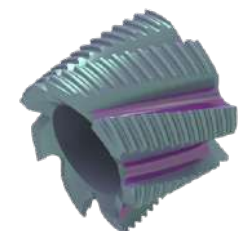
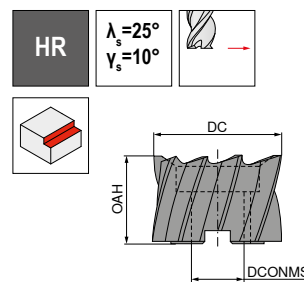

Ti100 Pro

DIN 1880

54 037 ...

DC _{js14} mm	OAH mm	DCONMS mm	ZEFP	£ U8	
40	32	16	7	201.93	040
50	36	22	8	249.65	050
63	40	27	8	540.48	063
80	45	27	10	536.68	080

P	●
M	●
K	●
N	●
S	○
H	●
O	●

→ v_c/f_z Page 39+40

Material examples for cutting data tables

	Material sub-group	Index	Composition / Structure / Heat treatment	Tensile strength N/mm ² / HB / HRC	Material number	Material designation	Material number	Material designation
P	Unalloyed steel	P.1.1	< 0,15 % C Annealed	420 N/mm ² / 125 HB	1.0401	C15	1.1141	Ck15
		P.1.2	< 0,45 % C Annealed	640 N/mm ² / 190 HB	1.1191	C45E	1.0718	9SMnPb28
		P.1.3	< 0,45 % C Tempered	840 N/mm ² / 250 HB	1.1191	C45E	1.0535	C55
		P.1.4	< 0,75 % C Annealed	910 N/mm ² / 270 HB	1.1223	C60R	1.0535	C55
		P.1.5	< 0,75 % C Tempered	1010 N/mm ² / 300 HB	1.1223	C60R	1.0727	45S20
	Low-alloy steel	P.2.1	Annealed	610 N/mm ² / 180 HB	1.7131	16MnCr5	1.6587	17CrNiMo6
		P.2.2	Tempered	930 N/mm ² / 275 HB	1.7131	16MnCr5	1.6587	17CrNiMo6
		P.2.3	Tempered	1010 N/mm ² / 300 HB	1.7225	42CrMo4	1.3505	100Cr6
		P.2.4	Tempered	1200 N/mm ² / 375 HB	1.7225	42CrMo4	1.3505	100Cr6
	High-alloy steel and high-alloy tool steel	P.3.1	Annealed	680 N/mm ² / 200 HB	1.4021	X20Cr13	1.4034	X46Cr13
		P.3.2	Hardened and tempered	1100 N/mm ² / 300 HB	1.2343	X38CrMoV5-1	1.4034	X46Cr13
		P.3.3	Hardened and tempered	1300 N/mm ² / 400 HB	1.2343	X38CrMoV5-1	1.4034	X46Cr13
	Stainless steel	P.4.1	Ferritic / martensitic Annealed	680 N/mm ² / 200 HB	1.4016	X6Cr17	1.2316	X36CrMo16
		P.4.2	Martensitic Tempered	1010 N/mm ² / 300 HB	1.4112	X90CrMoV18	1.2316	X36CrMo16
M	Stainless steel	M.1.1	Austenitic / austenitic-ferritic Quenched	610 N/mm ² / 180 HB	1.4301	X5CrNi18-10	1.4571	X6CrNiMoTi17-12-2
		M.2.1	Austenitic Tempered	300 HB	1.4841	X15CrNiSi25-21	1.4539	X1NiCrMoCu25-20-5
		M.3.1	Austenitic / ferritic (Duplex)	780 N/mm ² / 230 HB	1.4462	X2CrNiMoN22-5-3	1.4501	X2CrNiMoCuWN25-7-4
K	Grey cast iron	K.1.1	Pearlitic / ferritic	350 N/mm ² / 180 HB	0.6010	GG-10	0.6025	GG-25
		K.1.2	Pearlitic (martensitic)	500 N/mm ² / 260 HB	0.6030	GG-30	0.6045	GG-45
	Spherulitic graphite cast iron	K.2.1	Ferritic	540 N/mm ² / 160 HB	0.7040	GGG-40	0.7060	GGG-60
		K.2.2	Pearlitic	845 N/mm ² / 250 HB	0.7070	GGG-70	0.7080	GGG-80
	Malleable iron	K.3.1	Ferritic	440 N/mm ² / 130 HB	0.8035	GTW-35-04	0.8045	GTW-45
		K.3.2	Pearlitic	780 N/mm ² / 230 HB	0.8165	GTS-65-02	0.8170	GTS-70-02
N	Aluminium wrought alloy	N.1.1	Non-hardenable	60 HB	3.0255	Al99,5	3.3315	AlMg1
		N.1.2	Hardenable Age-hardened	340 N/mm ² / 100 HB	3.1355	AlCuMg2	3.2315	AlMgSi1
	Cast aluminium alloy	N.2.1	≤ 12 % Si, non-hardenable	250 N/mm ² / 75 HB	3.2581	G-AlSi12	3.2163	G-AlSi9Cu3
		N.2.2	≤ 12 % Si, hardenable Age-hardened	300 N/mm ² / 90 HB	3.2134	G-AlSi5Cu1Mg	3.2373	G-AlSi9Mg
		N.2.3	> 12 % Si, non-hardenable	440 N/mm ² / 130 HB		G-AlSi17Cu4Mg		G-AlSi18CuNiMg
	Copper and copper alloys (bronze/brass)	N.3.1	Free-machining alloys, PB > 1 %	375 N/mm ² / 110 HB	2.0380	CuZn39Pb2 (Ms58)	2.0410	CuZn44Pb2
		N.3.2	CuZn, CuSnZn	300 N/mm ² / 90 HB	2.0331	CuZn15	2.4070	CuZn28Sn1As
		N.3.3	CuSn, lead-free copper and electrolytic copper	340 N/mm ² / 100 HB	2.0060	E-Cu57	2.0590	CuZn40Fe
	Magnesium alloys	N.4.1	Magnesium and magnesium alloys	70 HB	3.5612	MgAl6Zn	3.5312	MgAl3Zn
	S	Heat-resistant alloys	S.1.1	Fe - basis Annealed	680 N/mm ² / 200 HB	1.4864	X12NiCrSi 36-16	1.4865
S.1.2			Fe - basis Age-hardened	950 N/mm ² / 280 HB	1.4980	X6NiCrTiMoVB25-15-2	1.4876	X10NiCrAlTi32-20
S.2.1			Ni or Co basis Annealed	840 N/mm ² / 250 HB	2.4631	NiCr20TiAl (Nimonic80A)	3.4856	NiCr22Mo9Nb
S.2.2			Ni or Co basis Age-hardened	1180 N/mm ² / 350 HB	2.4668	NiCr19Nb5Mo3 (Inconel 718)	2.4955	NiFe25Cr20NbTi
S.2.3			Ni or Co basis Cast	1080 N/mm ² / 320 HB	2.4765	CoCr20W15Ni	1.3401	G-X120Mn12
Titanium alloys		S.3.1	Pure titanium	400 N/mm ²	3.7025	Ti99,8	3.7034	Ti99,7
		S.3.2	Alpha + beta alloys Age-hardened	1050 N/mm ² / 320 HB	3.7165	TiAl6V4	Ti-6246	Ti-6Al-2Sn-4Zr-6Mo
S.3.3	Beta alloys	1400 N/mm ² / 410 HB	Ti555.3	Ti-5Al-5V-5Mo-3Cr	R56410	Ti-10V-2Fe-3Al		
H	Hardened steel	H.1.1	Hardened and tempered	46–55 HRC				
		H.1.2	Hardened and tempered	56–60 HRC				
		H.1.3	Hardened and tempered	61–65 HRC				
		H.1.4	Hardened and tempered	66–70 HRC				
	Chilled iron	H.2.1	Cast	400 HB				
	Hardened cast iron	H.3.1	Hardened and tempered	55 HRC				
O	Non-metal materials	O.1.1	Plastics, duroplastic	≤ 150 N/mm ²				
		O.1.2	Plastics, thermoplastic	≤ 100 N/mm ²				
		O.2.1	Aramid fibre-reinforced	≤ 1000 N/mm ²				
		O.2.2	Glass/carbon-fibre reinforced	≤ 1000 N/mm ²				
		O.3.1	Graphite					

* Tensile strength

Cutting speeds – slot, end milling and ball-nosed end milling cutters

Index	Kf f _z	uncoated	Ti100 Pro	Ti100 Pro	● 1st choice ○ suitable		
				Powder steel	Emulsion	Compressed air	MMS
		v _c (m/min)					
P.1.1	1,2	20	45	50	●		
P.1.2	1,2	20	45	50	●		
P.1.3	1,2	20	45	50	●		
P.1.4	1,0	15	30	35	●		
P.1.5	1,0	15	30	35	●		
P.2.1	1,2	20	40	45	●		
P.2.2	1,0	15	40	45	●		
P.2.3	0,8	15	30	35	●		
P.2.4	0,8	15	30	35	●		
P.3.1	1,0	15	30	35	●		
P.3.2	0,8	12	25	30	●		
P.3.3	0,8	10	20	25	●		
P.4.1	1,0	10	20	25	●		
P.4.2	1,0	10	20	25	●		
M.1.1	1,0	10	20	25	●		
M.2.1	0,9	7	15	20	●		
M.3.1	1,0	5	10	15	●		
K.1.1	1,0	18	35	40	●		
K.1.2	1,0	18	25	30	●		
K.2.1	1,0	15	30	35	●		
K.2.2	1,0	15	30	35	●		
K.3.1	1,0	15	35	40	●		
K.3.2	0,8	12	25	30	●		
N.1.1	1,9	150	240	260	●		
N.1.2	1,9	100	130	150	●		
N.2.1	1,8		100	140	●		
N.2.2	1,7		60	80	●		
N.2.3							
N.3.1	1,1		100	130	●		
N.3.2	1,2	30	60	80	●		
N.3.3	1,2	30	60	80	●		
N.4.1	1,8	90	140	160		●	
S.1.1							
S.1.2							
S.2.1							
S.2.2							
S.2.3							
S.3.1	1,0	10	15	25	●		
S.3.2	1,1	10	15	25	●		
S.3.3							
H.1.1							
H.1.2							
H.1.3							
H.1.4							
H.2.1							
H.3.1							
O.1.1	2,0	30	50	70	●		
O.1.2	2,0	20	25	40	●		
O.2.1							
O.2.2							
O.3.1	1,0		30	40	○		

 For full slot milling reduce the cutting speed (v_c), indicated in this table by approx. 15 – 20%!
Kf f_z = Correction factor for feed per tooth

Feed per tooth for HSS end mills

Approximate values (in mm) for the feed per tooth (f_z)

Ø DC mm	Finish milling						Rough machining					
	Peripheral milling						Full slot milling					
	f_z in mm		f_z in mm		f_z in mm		f_z in mm		f_z in mm		f_z in mm	
	uncoated	coated	uncoated	coated	uncoated	coated	uncoated	coated	uncoated	coated	uncoated	coated
2	0,008	0,009	0,008	0,009	0,008	0,009						
3	0,011	0,012	0,009	0,010	0,010	0,012						
4	0,017	0,018	0,013	0,014	0,014	0,015	0,015	0,016	0,013	0,014	0,011	0,012
5	0,024	0,026	0,014	0,015	0,018	0,020	0,019	0,021	0,016	0,018	0,014	0,016
6	0,032	0,035	0,015	0,017	0,022	0,024	0,024	0,027	0,020	0,022	0,018	0,019
8	0,047	0,051	0,020	0,022	0,029	0,032	0,032	0,036	0,027	0,030	0,024	0,026
10	0,065	0,072	0,026	0,028	0,037	0,041	0,042	0,047	0,035	0,039	0,031	0,034
12	0,084	0,091	0,031	0,034	0,044	0,049	0,051	0,057	0,043	0,047	0,037	0,041
14	0,100	0,106	0,037	0,041	0,054	0,059	0,063	0,069	0,053	0,058	0,045	0,050
16	0,111	0,121	0,042	0,046	0,061	0,067	0,072	0,079	0,060	0,066	0,052	0,057
18	0,126	0,136	0,048	0,053	0,070	0,077	0,084	0,093	0,071	0,078	0,061	0,067
20	0,141	0,151	0,052	0,057	0,076	0,083	0,092	0,101	0,077	0,084	0,066	0,073
22	0,160	0,166	0,059	0,065	0,085	0,094	0,104	0,114	0,087	0,096	0,075	0,082
25	0,170	0,188	0,065	0,072	0,095	0,104	0,117	0,129	0,098	0,108	0,084	0,093
28	0,196	0,210	0,075	0,083	0,109	0,120	0,136	0,150	0,114	0,125	0,098	0,108
32	0,212	0,240	0,086	0,094	0,124	0,137	0,157	0,173	0,131	0,145	0,113	0,125
36	0,224	0,240	0,099	0,109	0,144	0,159	0,170	0,194	0,142	0,162	0,126	0,140
40	0,240	0,240	0,108	0,119	0,157	0,173	0,184	0,202	0,154	0,169	0,132	0,146
45	0,240	0,240	0,108	0,119	0,157	0,173	0,200	0,220	0,170	0,180	0,140	0,160
50	0,240	0,240	0,108	0,119	0,157	0,173	0,200	0,220	0,170	0,180	0,140	0,160

Attention:
In the case of uncoated milling cutters climb milling is preferred to conventional milling. When using coated milling cutters climb milling is necessary in order to achieve optimum results.

Feed rate correction:
Please multiply the f_z value in the table above with the corresponding **correction factor Kf f_z** from the table on → **page 33**.

In general the following is valid:
 f_z (milling) = $f_z \times Kf f_z$
 f_z (drilling) = f_z (milling) ÷ no. of teeth

Feed per tooth when milling parallel key slots with HSS slot drills

Approximate values (in mm) for the feed per tooth (f_z)

Ø DC mm	Full slot milling (in one cut)		Profile slot milling (internal profile milling)				Circular ramping			
			Roughing cut		Finishing cut					
	f_z in mm		f_z in mm				f_z in mm			
	uncoated	coated	uncoated	coated	uncoated	coated	uncoated	coated	uncoated	coated
2	0,005	0,006	0,005	0,006	0,008	0,009	0,003	0,003	0,002	0,002
3	0,009	0,010	0,009	0,010	0,015	0,016	0,004	0,005	0,003	0,003
4	0,012	0,013	0,012	0,013	0,022	0,024	0,006	0,007	0,004	0,004
5	0,016	0,017	0,016	0,017	0,030	0,033	0,008	0,009	0,005	0,006
6	0,020	0,022	0,020	0,022	0,039	0,043	0,010	0,011	0,007	0,007
8	0,026	0,029	0,026	0,029	0,055	0,061	0,013	0,014	0,009	0,010
10	0,034	0,037	0,034	0,037	0,075	0,082	0,017	0,019	0,011	0,012
12	0,040	0,044	0,040	0,044	0,093	0,101	0,020	0,022	0,013	0,015
14	0,049	0,054	0,049	0,054	0,117	0,118	0,024	0,027	0,016	0,018
16	0,056	0,062	0,056	0,062	0,135	0,135	0,028	0,031	0,019	0,021
18	0,065	0,072	0,065	0,072	0,151	0,151	0,033	0,036	0,022	0,024
20	0,071	0,078	0,071	0,078	0,167	0,167	0,035	0,039	0,024	0,026
22	0,080	0,088	0,080	0,088	0,184	0,184	0,040	0,044	0,027	0,029
25	0,089	0,098	0,089	0,098	0,208	0,208	0,044	0,049	0,030	0,033
28	0,103	0,113	0,103	0,113	0,233	0,233	0,051	0,056	0,034	0,037
32	0,118	0,130	0,118	0,130	0,260	0,260	0,060	0,065	0,040	0,043
36	0,130	0,143	0,130	0,143	0,260	0,260	0,060	0,065	0,040	0,043
40	0,130	0,143	0,130	0,143	0,260	0,260	0,060	0,065	0,040	0,043
45	0,130	0,143	0,130	0,143	0,260	0,260	0,060	0,065	0,040	0,043
50	0,130	0,143	0,130	0,143	0,260	0,260	0,060	0,065	0,040	0,043

Attention:
In the case of uncoated milling cutters climb milling is preferred to conventional milling.
When using coated milling cutters climb milling is necessary in order to achieve optimum results.

Feed rate correction:
Please multiply the f_z value in the table above with the corresponding **correction factor Kf f_z** from the table on → **page 33**.

In general the following is valid:
 f_z (milling) = $f_z \times Kf f_z$
 f_z (drilling) = f_z (milling) ÷ no. of teeth

Cutting data standard values – Form cutters

Index	v _c (m/min)	50 241 ...			50 240 ...					v _c (m/min)	50 234 ...				50 248 ...				● 1st choice ○ suitable		
		Ø DC (mm) =			Ø DC (mm) =						Ø DC (mm) =				Ø DCX (mm) =				Emulsion	Compressed air	MMS
		21-25	28-36	40-45	11-16	18-22	25-32	36-45	50-60		10-17	19-26	28-33	33-46	8-11	12-24	26-34	46-48			
		f (mm)			f (mm)						f (mm)				f (mm)						
P.1.1	28	0,07	0,1	0,12	0,015	0,03	0,03	0,03	0,04	28	0,02	0,03	0,04	0,05	0,03	0,06	0,1	0,12	●		
P.1.2	28	0,07	0,1	0,12	0,015	0,03	0,03	0,03	0,04	28	0,02	0,03	0,04	0,05	0,03	0,06	0,1	0,12	●		
P.1.3	28	0,07	0,1	0,12	0,015	0,03	0,03	0,03	0,04	28	0,02	0,03	0,04	0,05	0,03	0,06	0,1	0,12	●		
P.1.4	22	0,06	0,08	0,1	0,015	0,03	0,03	0,03	0,04	22	0,02	0,03	0,035	0,045	0,025	0,055	0,08	0,1	●		
P.1.5	22	0,06	0,08	0,1	0,015	0,03	0,03	0,03	0,04	22	0,02	0,03	0,035	0,045	0,025	0,055	0,08	0,1	●		
P.2.1	22	0,06	0,08	0,1	0,015	0,03	0,03	0,03	0,04	22	0,02	0,03	0,035	0,045	0,025	0,055	0,08	0,1	●		
P.2.2	28	0,07	0,1	0,12	0,015	0,03	0,03	0,03	0,04	28	0,02	0,03	0,04	0,05	0,03	0,06	0,1	0,12	●		
P.2.3	20	0,06	0,08	0,1	0,015	0,03	0,03	0,03	0,04	20	0,02	0,03	0,035	0,045	0,025	0,055	0,08	0,1	●		
P.2.4	20	0,06	0,08	0,1	0,015	0,03	0,03	0,03	0,04	20	0,02	0,03	0,035	0,045	0,025	0,055	0,08	0,1	●		
P.3.1																					
P.3.2																					
P.3.3																					
P.4.1	10	0,06	0,08	0,1	0,01	0,025	0,025	0,025	0,03	10	0,02	0,025	0,03	0,04	0,02	0,045	0,08	0,09	●		
P.4.2	10	0,06	0,08	0,1	0,01	0,025	0,025	0,025	0,03	10	0,02	0,025	0,03	0,04	0,02	0,045	0,08	0,09	●		
M.1.1	10	0,06	0,08	0,1	0,01	0,025	0,025	0,025	0,03	10	0,02	0,025	0,03	0,04	0,02	0,045	0,08	0,09	●		
M.2.1																					
M.3.1																					
K.1.1	28	0,07	0,1	0,12	0,015	0,03	0,025	0,04	0,035	24	0,025	0,03	0,04	0,05	0,03	0,06	0,1	0,12	●		
K.1.2																					
K.2.1	22	0,07	0,1	0,12	0,015	0,03	0,025	0,04	0,035	22	0,025	0,03	0,04	0,05	0,03	0,06	0,1	0,12	●		
K.2.2	20	0,07	0,1	0,12	0,015	0,03	0,025	0,04	0,035	20	0,025	0,03	0,04	0,05	0,03	0,06	0,1	0,12	●		
K.3.1	15	0,07	0,1	0,12	0,015	0,03	0,025	0,04	0,035	15	0,025	0,03	0,04	0,05	0,03	0,06	0,1	0,12	●		
K.3.2	15	0,07	0,1	0,12	0,015	0,03	0,025	0,04	0,035	15	0,025	0,03	0,04	0,05	0,03	0,06	0,1	0,12	●		
N.1.1	100	0,1	0,12	0,15	0,02	0,045	0,045	0,045	0,055	90	0,03	0,04	0,06	0,07	0,035	0,07	0,14	0,15	●		
N.1.2	100	0,1	0,12	0,15	0,02	0,045	0,045	0,045	0,055	90	0,03	0,04	0,06	0,07	0,035	0,07	0,14	0,15	●		
N.2.1	80	0,09	0,11	0,13	0,015	0,04	0,035	0,04	0,045	80	0,03	0,035	0,045	0,055	0,03	0,06	0,12	0,12	●		
N.2.2	60	0,09	0,11	0,13	0,015	0,04	0,035	0,04	0,045	60	0,03	0,035	0,045	0,055	0,03	0,06	0,12	0,12	●		
N.2.3																					
N.3.1	25	0,08	0,1	0,12	0,015	0,04	0,035	0,03	0,035	25	0,02	0,035	0,045	0,055	0,03	0,06	0,12	0,12	●		
N.3.2	25	0,08	0,1	0,12	0,015	0,04	0,035	0,03		25	0,02	0,035	0,045	0,055	0,03	0,06	0,12	0,12	●		
N.3.3	25	0,08	0,1	0,12	0,015	0,04	0,035	0,03		25	0,02	0,035	0,045	0,055	0,03	0,06	0,12	0,12	●		
N.4.1	70	0,1	0,12	0,15	0,018	0,04	0,03	0,035	0,045	70	0,03	0,035	0,05	0,06	0,025	0,06	0,1	0,12	●		
S.1.1																					
S.1.2																					
S.2.1																					
S.2.2																					
S.2.3																					
S.3.1	20	0,06	0,08	0,1	0,012	0,025	0,025	0,025	0,035	20	0,015	0,025	0,035	0,045	0,02	0,05	0,07	0,09	●		
S.3.2																					
S.3.3																					
H.1.1																					
H.1.2																					
H.1.3																					
H.1.4																					
H.2.1																					
H.3.1																					
O.1.1	65	0,12	0,15	0,18		0,06	0,055	0,055	0,07	65	0,04	0,05	0,07	0,09	0,045	0,1	0,18	0,18	●		
O.1.2	80	0,12	0,15	0,18		0,06	0,055	0,055	0,07	80	0,04	0,05	0,07	0,09	0,045	0,1	0,18	0,18	●		
O.2.1																					
O.2.2																					
O.3.1																					



The cutting data depends largely on the external conditions, e.g. stability of the tools and tool clamping, material and machine type. The indicated values are possible cutting data which have to be increased or reduced according to the application conditions.

Cutting data standard values – Form cutters

Index	v _c (m/min)	50 245 ... / 50 246 ...			v _c (m/min)	50 360 ...				50 362 ...				● 1st choice ○ suitable		
		Ø DC (mm) =				Ø DC (mm) =				Ø DC (mm) =				Emulsion	Compressed air	MMS
		16	20	25		50	63	80	100	40-50	63	80	100			
		a _e = 3,2	a _e = 4	a _e = 5		a _e = 5	a _e = 6,3	a _e = 8	a _e = 10	f (mm)						
P.1.1	28	0,01	0,015	0,018	22	0,01	0,01	0,015	0,02	0,005	0,008	0,01	0,012	●		
P.1.2	28	0,01	0,015	0,018	22	0,01	0,01	0,015	0,02	0,005	0,008	0,01	0,012	●		
P.1.3	28	0,01	0,015	0,018	22	0,01	0,01	0,015	0,02	0,005	0,008	0,01	0,012	●		
P.1.4	22	0,01	0,015	0,018	20	0,008	0,01	0,012	0,018	0,005	0,008	0,01	0,012	●		
P.1.5	22	0,01	0,015	0,018	20	0,01	0,01	0,015	0,02	0,005	0,008	0,01	0,012	●		
P.2.1	22	0,01	0,015	0,018	20	0,01	0,01	0,015	0,02	0,005	0,008	0,01	0,012	●		
P.2.2	28	0,01	0,015	0,018	22	0,008	0,01	0,012	0,018	0,005	0,008	0,01	0,012	●		
P.2.3	20	0,01	0,015	0,018	20	0,01	0,01	0,015	0,02	0,005	0,008	0,01	0,012	●		
P.2.4	20	0,01	0,015	0,018	20	0,01	0,01	0,015	0,02	0,005	0,008	0,01	0,012	●		
P.3.1																
P.3.2																
P.3.3																
P.4.1	10	0,007	0,01	0,012	10	0,008	0,01	0,012	0,018	0,005	0,008	0,01	0,012	●		
P.4.2	10	0,007	0,01	0,012	10	0,008	0,01	0,012	0,018	0,005	0,008	0,01	0,012	●		
M.1.1	10	0,007	0,01	0,012	10	0,008	0,01	0,012	0,018	0,005	0,008	0,01	0,012	●		
M.2.1																
M.3.1																
K.1.1	24	0,01	0,012	0,015	19	0,008	0,01	0,012	0,018	0,005	0,008	0,01	0,012	●		
K.1.2					12	0,008	0,01	0,012	0,018	0,005	0,008	0,01	0,012	●		
K.2.1	22	0,01	0,012	0,015	15	0,008	0,01	0,012	0,018	0,005	0,008	0,01	0,012	●		
K.2.2	20	0,01	0,012	0,015	12	0,008	0,01	0,012	0,018	0,005	0,008	0,01	0,012	●		
K.3.1	15	0,01	0,012	0,015	16	0,008	0,01	0,012	0,018	0,005	0,008	0,01	0,012	●		
K.3.2	15	0,01	0,012	0,015	13	0,008	0,01	0,012	0,018	0,005	0,008	0,01	0,012	●		
N.1.1	90	0,01	0,015	0,02										●		
N.1.2	90	0,01	0,015	0,02	70	0,012	0,015	0,02	0,024	0,008	0,012	0,014	0,018	●		
N.2.1	80	0,01	0,015	0,02	60	0,012	0,015	0,02	0,024	0,008	0,012	0,014	0,018	●		
N.2.2	60	0,01	0,015	0,02	60	0,012	0,015	0,02	0,024	0,008	0,012	0,014	0,018	●		
N.2.3																
N.3.1	25	0,01	0,015	0,02	20	0,01	0,012	0,015	0,018	0,005	0,008	0,01	0,012	●		
N.3.2	25	0,01	0,015	0,02	20	0,01	0,012	0,015	0,018	0,005	0,008	0,01	0,012	●		
N.3.3	25	0,01	0,015	0,02	20	0,01	0,012	0,015	0,018	0,005	0,008	0,01	0,012	●		
N.4.1	70	0,01	0,015	0,0175	45	0,01	0,012	0,015	0,018	0,005	0,008	0,01	0,01	●		
S.1.1																
S.1.2																
S.2.1																
S.2.2																
S.2.3																
S.3.1	20	0,008	0,01	0,015	20	0,008	0,01	0,012	0,016	0,005	0,007	0,009	0,012	●		
S.3.2																
S.3.3																
H.1.1																
H.1.2																
H.1.3																
H.1.4																
H.2.1																
H.3.1																
O.1.1	65	0,018	0,02	0,025	60	0,015	0,02	0,025	0,03	0,008	0,012	0,018	0,022	●		
O.1.2	80	0,018	0,02	0,025	65	0,015	0,02	0,025	0,03	0,008	0,012	0,018	0,022	●		
O.2.1																
O.2.2																
O.3.1																

 The cutting data depends largely on the external conditions, e.g. stability of the tools and tool clamping, material and machine type. The indicated values are possible cutting data which have to be increased or reduced according to the application conditions.

Cutting data - side and face cutters

Index	v _c (m/min)	50 340 ... / 50 349 ...						● 1st choice ○ suitable		
		Ø DC (mm) =						Emulsion	Compressed air	MMS
		50	63	80	100	125	160			
f (mm)										
P.1.1	30	0,025-0,030	0,030-0,035	0,035-0,040	0,040-0,045	0,047-0,055	0,050-0,060	●		
P.1.2	20	0,025-0,030	0,030-0,035	0,035-0,040	0,040-0,045	0,047-0,055	0,050-0,060	●		
P.1.3	20	0,025-0,035	0,030-0,040	0,035-0,045	0,040-0,050	0,047-0,060	0,050-0,065	●		
P.1.4	15	0,020-0,025	0,025-0,030	0,030-0,035	0,035-0,040	0,040-0,045	0,045-0,050	●		
P.1.5	15	0,020-0,025	0,025-0,030	0,030-0,035	0,035-0,040	0,040-0,045	0,045-0,050	●		
P.2.1	20	0,020-0,025	0,025-0,030	0,030-0,035	0,035-0,040	0,040-0,045	0,045-0,050	●		
P.2.2	20	0,020-0,025	0,025-0,030	0,030-0,035	0,035-0,040	0,040-0,045	0,045-0,050	●		
P.2.3	10	0,015-0,020	0,020-0,025	0,025-0,030	0,030-0,035	0,035-0,040	0,040-0,045	●		
P.2.4	10	0,015-0,020	0,020-0,025	0,025-0,030	0,030-0,035	0,035-0,040	0,040-0,045	●		
P.3.1	15	0,020-0,025	0,025-0,030	0,030-0,035	0,035-0,040	0,040-0,045	0,045-0,050	●		
P.3.2	10	0,015-0,020	0,020-0,025	0,025-0,030	0,030-0,035	0,035-0,040	0,040-0,045	●		
P.3.3	10	0,015-0,020	0,020-0,025	0,025-0,030	0,030-0,035	0,035-0,040	0,040-0,045	●		
P.4.1	10	0,020-0,025	0,025-0,030	0,030-0,035	0,035-0,040	0,040-0,045	0,045-0,050	●		
P.4.2	10	0,020-0,030	0,025-0,035	0,030-0,040	0,035-0,045	0,040-0,050	0,045-0,100	●		
M.1.1	10	0,015-0,020	0,020-0,025	0,025-0,030	0,030-0,035	0,035-0,040	0,040-0,045	●		
M.2.1	10	0,015-0,020	0,020-0,025	0,025-0,030	0,030-0,035	0,035-0,040	0,040-0,045	●		
M.3.1	8	0,020-0,025	0,025-0,030	0,030-0,035	0,035-0,040	0,040-0,045	0,045-0,050	●		
K.1.1	20	0,020-0,025	0,025-0,030	0,030-0,035	0,035-0,040	0,040-0,045	0,045-0,050	●		
K.1.2	18	0,020-0,025	0,025-0,030	0,030-0,035	0,035-0,040	0,040-0,045	0,045-0,050	●		
K.2.1	18	0,020-0,025	0,025-0,030	0,030-0,035	0,035-0,040	0,040-0,045	0,045-0,050	●		
K.2.2	15	0,020-0,025	0,025-0,030	0,030-0,035	0,035-0,040	0,040-0,045	0,045-0,050	●		
K.3.1	18	0,020-0,025	0,025-0,030	0,030-0,035	0,035-0,040	0,040-0,045	0,045-0,050	●		
K.3.2	18	0,020-0,025	0,025-0,030	0,030-0,035	0,035-0,040	0,040-0,045	0,045-0,050	●		
N.1.1	150	0,030-0,037	0,037-0,045	0,045-0,050	0,050-0,060	0,060-0,067	0,067-0,075	●		
N.1.2	100	0,030-0,037	0,037-0,045	0,045-0,050	0,050-0,060	0,060-0,067	0,067-0,075	●		
N.2.1	80	0,025-0,030	0,030-0,035	0,035-0,040	0,040-0,045	0,047-0,055	0,050-0,060	●		
N.2.2	40	0,025-0,030	0,030-0,035	0,035-0,040	0,040-0,045	0,047-0,055	0,050-0,060	●		
N.2.3										
N.3.1	80	0,020-0,025	0,025-0,030	0,030-0,035	0,035-0,040	0,040-0,045	0,045-0,050	●		
N.3.2	30	0,025-0,030	0,030-0,035	0,035-0,040	0,040-0,045	0,047-0,055	0,050-0,060	●		
N.3.3	30	0,025-0,035	0,030-0,040	0,035-0,045	0,040-0,050	0,047-0,060	0,050-0,065	●		
N.4.1	90	0,025-0,030	0,030-0,035	0,035-0,040	0,040-0,045	0,047-0,055	0,050-0,060		●	
S.1.1										
S.1.2										
S.2.1										
S.2.2										
S.2.3										
S.3.1	10	0,020-0,025	0,025-0,030	0,030-0,035	0,035-0,040	0,040-0,045	0,045-0,050	●		
S.3.2	10	0,020-0,025	0,025-0,030	0,030-0,035	0,035-0,040	0,040-0,045	0,045-0,050	●		
S.3.3										
H.1.1										
H.1.2										
H.1.3										
H.1.4										
H.2.1										
H.3.1										
O.1.1	30	0,040-0,050	0,050-0,060	0,060-0,070	0,070-0,080	0,080-0,090	0,090-0,100	●		
O.1.2	20	0,040-0,050	0,050-0,060	0,060-0,070	0,070-0,080	0,080-0,090	0,090-0,100	●		
O.2.1										
O.2.2										
O.3.1										

 Feed correction factor (Kf f_z) for side and face cutters in relation to the cutting depth (a_e)

a _e	Kf f _z
0,05 x DC	1,4
0,1 x DC	1,0
0,15 x DC	0,8
0,2 x DC	0,7
0,25 x DC	0,6

Cutting data – face mills

Index	Kf f _z	50 250 ... / 50 260 ...	54 035 ... / 54 037 ...	● 1st choice ○ suitable		
		uncoated	Ti100 Pro	Emulsion	Compressed air	MMS
		v _c (m/min)	v _c (m/min)			
P.1.1	1,2	25	45	●		
P.1.2	1,2	20	40	●		
P.1.3	1,2	20	40	●		
P.1.4	1,0	15	30	●		
P.1.5	1,0	15	30	●		
P.2.1	1,2	20	40	●		
P.2.2	1,0	20	40	●		
P.2.3	0,8	10	20	●		
P.2.4	0,8	10	20	●		
P.3.1	1,0	15	30	●		
P.3.2	0,8	10	20	●		
P.3.3	0,8	10	20	●		
P.4.1	1,0	10	15	●		
P.4.2	1,0	10	15	●		
M.1.1	1,0	10	15	●		
M.2.1	0,9	7	15	●		
M.3.1	1,0	5	10	●		
K.1.1	1,0	20	30	●		
K.1.2	1,0	18	30	●		
K.2.1	1,0	18	30	●		
K.2.2	1,0	15	25	●		
K.3.1	1,0	18	30	●		
K.3.2	1,0	18	30	●		
N.1.1	1,5	150				
N.1.2	1,5	100				
N.2.1	1,3	80				
N.2.2	1,3	40				
N.2.3						
N.3.1	1,1	80	110	●		
N.3.2	1,2	30	60	●		
N.3.3	1,2	30	60	●		
N.4.1	1,3	90	120		●	
S.1.1						
S.1.2						
S.2.1						
S.2.2						
S.2.3						
S.3.1	1,0	10	15	●		
S.3.2	1,1	10	15	●		
S.3.3	0,8		10	●		
H.1.1						
H.1.2						
H.1.3						
H.1.4						
H.2.1						
H.3.1						
O.1.1	2,0	30	50	●		
O.1.2	2,0	20	25	●		
O.2.1						
O.2.2						
O.3.1						

Feed per tooth for HSS face mills

Approximate values (in mm) for the feed per tooth (f_z)

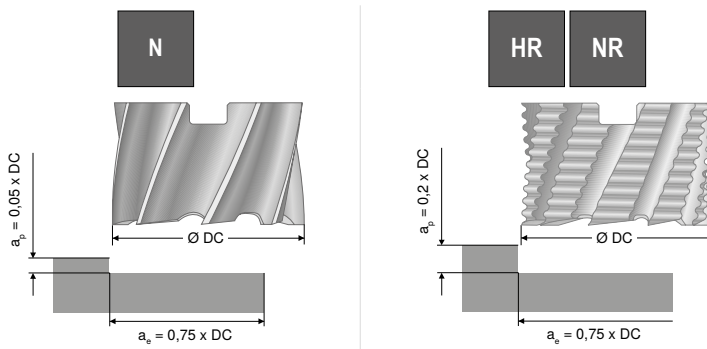

Ø DC mm	f_z in mm		f_z in mm	
	uncoated	Ti100 Pro	uncoated	Ti100 Pro
40	0,049	0,054	0,064	0,070
50	0,055	0,060	0,071	0,078
63	0,061	0,067	0,079	0,087
80	0,065	0,071	0,084	0,092



Feed rate correction:

Please multiply the f_z value in the table above with the corresponding **correction factor $K_f f_z$** from the table on → **page 39**.

In general the following is valid:

$$f_z \text{ (milling)} = f_z \times K_f f_z$$

$$f_z \text{ (drilling)} = f_z \text{ (milling)} \div \text{no. of teeth}$$

Formula for cutting data calculation

Designation	Abbreviation	Unit	Formula
Number of revolutions	n	min ⁻¹	$n = \frac{v_c \times 1000}{DC \times \pi}$
Cutting speed	v_c	m/min	$v_c = \frac{DC \times \pi \times n}{1000}$
Feed per tooth	f_z	mm	$f_z = \frac{v_f}{ZEFP \times n}$ $f_z = h_m \times \sqrt{\frac{DC}{a_e}}$
Feed per revolution	f	mm	$f = f_z \times ZEFP$
Feed rate	v_f	mm/min.	$v_f = f_z \times ZEFP \times n$
Average chip thickness	h_m	mm	$h_m = f_z \times \sqrt{\frac{a_e}{DC}}$

ZEFP = Number of flutes





a_e = cutting width (for side milling cutter cutting depth)

DC = Cutting diameter

Version description

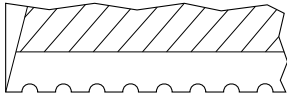
H	For high-strength steels and tempered materials	N	For machining steel and cast materials, as well as stainless steels
HF	For high-strength steels and tempered materials – with roughing-finishing profile	NF	For machining steel and cast materials, as well as stainless steels – with roughing-finishing profile
HR	For high-strength steels and tempered materials – with roughing profile	NR	For machining steel and cast materials, as well as stainless steels – with roughing profile
		W	For soft materials and non-ferrous metals (aluminium, copper, brass)

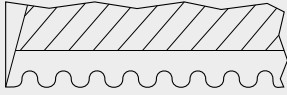
Differences between the milling cutter types

Designation	Type	Shape of the chip breaker	Application description	Chip shape
Rough and finish milling cutters	NF		<ul style="list-style-type: none"> ▲ High chip volume, even on less powerful machines ▲ Surface quality mostly sufficient ▲ Lower cutting pressure compared to smooth-edged milling cutters ▲ Finish machining not needed 	
	HF			
Rough milling cutters	NR		<ul style="list-style-type: none"> ▲ Produces very small and short chips ▲ Problem-solver in unstable conditions ▲ High chip volume, even on the weakest machines ▲ Exceptionally well suited to full slot milling ▲ Additional finish machining needed ▲ High feeds possible 	
	HR			

Coating

Ti100 Pro	<ul style="list-style-type: none"> ▲ Ti multilayer coating ▲ HV_{0.05} = 3500 ▲ Coefficient of friction (against steel) = 0.7 ▲ Maximum application temperature: 900°C
--------------	--