

New products for machining technicians

NEW Expansion of REAMAX TS / Monomax



- ▲ Expansion of the REAMAX TS and Monomax range with a Monomax version in two lengths (3xD and 5xD) and a REAMAX TS reaming head variant
- ▲ With coated carbide blanks – ideal for interrupted cuts: DBG-P ASG 3000
- ▲ Specially designed for through hole machining of cast iron and steel materials

Expansion REAMAX TS → Page 10
Expansion Monomax short → Page 22
Expansion Monomax long → Page 25

NEW Machine reamers sim. DIN 8093-A / -B



- ▲ Extremely irregular pitch
- ▲ Universal solid carbide reamer without thro' coolant

→ Page 48

NEW 90° Countersink with irregular pitch, DIN 335-C



- ▲ All sizes with 3 cutting edges and extremely irregular pitch, resulting in quiet running, excellent roundness and chatter-free countersinking giving the highest surface quality
- ▲ TiN coating and special HPC-TiN coating
- ▲ For a very long service life in almost all materials
- ▲ Greatly reduced axial and radial forces
- ▲ For DIN ISO 7721 and DIN 7991 countersunk head screws

Solid carbide version → Page 63
HSS version → Page 65

NEW Indexable insert countersink for counterbores



- ▲ Universal application and maximum service life thanks to use of tried-and-tested WOEX indexable inserts (grade: BK8425 / K10; chip breaker -01)
- ▲ For creating countersinks according to DIN 974
- ▲ With thro' coolant supply

→ Page 57+58



Solid drilling and bore machining

1 HSS drilling

2 Solid carbide drilling

3 Indexable insert drilling

4 Reaming and Countersinking

5 Spindle Tooling

Threading

6 Taps and thread formers

7 Circular and Thread Milling

8 Thread turning

Turning

9 Turning Tools

10 Multifunctional Tools – EcoCut and FreeTurn

11 Grooving Tools

12 Miniature turning tools

Milling

13 HSS Milling Cutters

14 Solid Carbide milling cutters

15 Milling tools with indexable inserts

Clamping technology

16 Adaptors and Accessories

17 Workpiece clamping

18 Material examples

Table of contents

Symbol explanation	4
Selection guide – reamers	5
Reamers Toolfinder	6+7
Contents overview – Countersinks	8
Product range – Reamers	
Solid carbide – high speed reamers	9–42
Solid carbide – Reamers	43–48
HSS – Reamers	49–56
Product range – Countersinks	57–68
Technical Information	
Cutting Data	69–95
REAMAX TS assembly and operating instructions	96+97
Problems / possible causes / solutions	98
Types of wear	99
Cutting edge geometries and surface quality	100
Tolerance classes covered with 1/100 reamer	101
Manufacturer's tolerance and coatings	102
Chip Breaker Types and Grade Overview	103

KOMET \ Performance

Premium quality tools for high performance.

The premium quality tools from the **KOMET Performance** product line have been designed for specific applications and are distinguished by their outstanding performance. If you make high demands on the performance of your production and want to achieve the very best results, we recommend the Premium tools in this product line.

KOMET \ Standard

Quality tools for standard applications.

The quality tools of the **KOMET Standard** product line are high quality, high performance, reliable and enjoy the highest level of trust among our customers worldwide. Tools from this product line are the first choice for many standard applications and guarantee optimal results.

Symbol explanation

Coolant supply version



central internal coolant



lateral internal coolant

Shank



Plain cylindrical shank



Morse taper



Cylindrical shank with lateral driving face „Weldon“

Applications



Through hole



Blind hole



Through hole with transverse hole/ interrupted cut



Blind hole with transverse hole/interrupted cut

ZEFP = Number of flutes

- = Main Application
- = Extended application



Selection guide – reamers

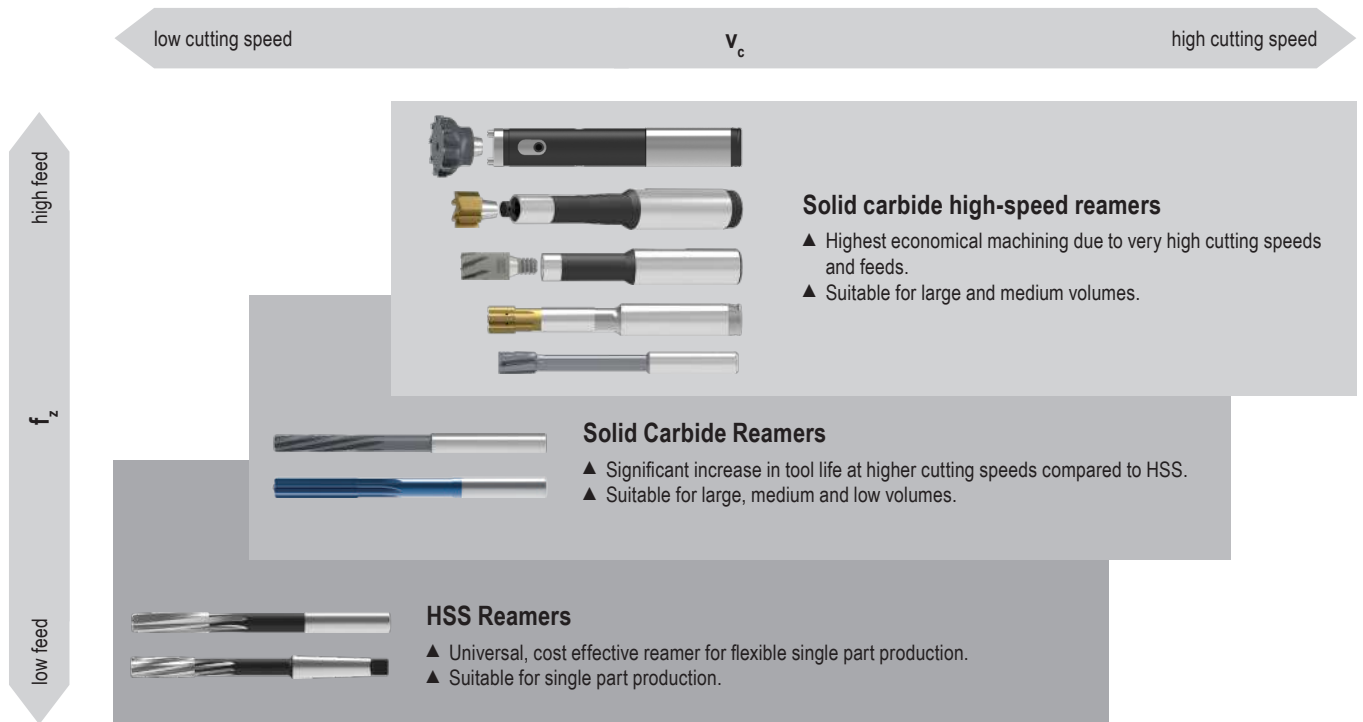



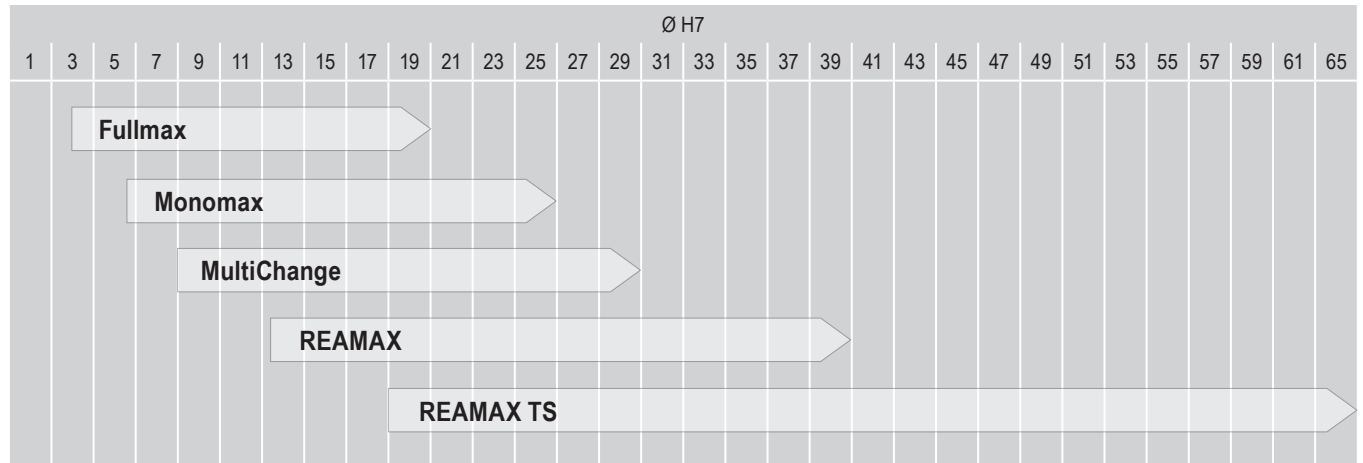





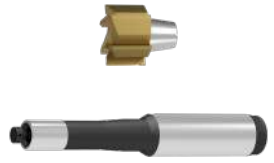



























Overview of solid carbide high-speed reamers

















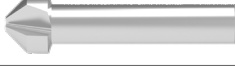

	mono	modular
fixed	<p>Fullmax</p> 	<p>MultiChange</p>  <p>REAMAX</p> 
adjustable	<p>Monomax</p> 	<p>REAMAX TS</p> 

Toolfinder – Reamers



Solid carbide – high speed reamers	REAMAXTS			<ul style="list-style-type: none"> ▲ highly flexible and economical replaceable head system ▲ all common materials ▲ can be adjusted in μm range
	REAMAX			<ul style="list-style-type: none"> ▲ holder available in 3xD and 5xD ▲ holder type DAH Zero available in 3xD and 5xD
	REMAX			<ul style="list-style-type: none"> ▲ Exchangeable head system, optimised for use with minimum quantity lubrication (MQL) ▲ Maximum changeover precision guaranteed thanks to face and taper contact
	MultiChange			<ul style="list-style-type: none"> ▲ holder available in 3xD and 5xD
	Monomax			<ul style="list-style-type: none"> ▲ Flexible quick change system for reaming, countersinking and milling ▲ A high level of changeover precision guaranteed thanks to face and taper contact
	Fullmax			<ul style="list-style-type: none"> ▲ stable holder in solid carbide and steel, from short to long
Solid carbide – Reamers	NC	NC 100		<ul style="list-style-type: none"> ▲ adjustable monoblock reamer in 3xD and 5xD ▲ regrinding and re-tipping on the base body ▲ all common materials
	NC	NC 100H		<ul style="list-style-type: none"> ▲ High-speed reamer in shorter and longer version ▲ Reamers for machining steel, stainless and acid-resistant steels, cast materials, aluminium and hardened materials up to 63 HRC ▲ Extremely irregular pitch ▲ Standard shank ~ DIN 6535 HA
	N			<ul style="list-style-type: none"> ▲ universal solid carbide reamer without thro' coolant ▲ extremely irregular pitch ▲ DIN 6535 HA shank
HSS – Reamers	NC	NC 100		<ul style="list-style-type: none"> ▲ Solid carbide reamer without thro' coolant suitable for use in hardened materials ▲ Standard shank ~ DIN 6535 HA
	N	N 100		<ul style="list-style-type: none"> ▲ universal solid carbide reamer without thro' coolant ▲ extremely irregular pitch
	AR	AR 100		<ul style="list-style-type: none"> ▲ HSS-E NC machine reamer ▲ DIN 1835 A shank
	N			<ul style="list-style-type: none"> ▲ HSS-E machine reamer
	H			<ul style="list-style-type: none"> ▲ HSS-E automatic machine reamer DIN 8089
				<ul style="list-style-type: none"> ▲ HSS-e machine reamer DIN 208 ▲ with Morse taper
				<ul style="list-style-type: none"> ▲ HSS hand reamer with cylindrical shank DIN 206

	Hole diameter (mm) Ø DC	Standard Tolerance	Through hole	Blind hole	Int. coolant supply	Steel P	Stainless steel M	Cast iron K	Non-ferrous metals N	Heat-resistant S	Tempered steel H	Non-metal materials O	KOMET \ Performance	KOMET \ Standard
	18,00–65,00	H7			✓	●	●	●	●			○	9–11	
		1/100			✓								12+13	
	12,50–40,00	H7			✓	●	●	●	●			○	14+15	
		1/100			✓								16	
	8,00–30,20	H7			✓	●	●	●	●				17–19	
		1/100			✓								→ Catalogue – Clamping technology, Chapter 16 Accessories	
short version	5,60–25,89	H7			✓	●	●	●	●			○	20–23	
		1/100			✓									
long version	5,60–25,89	H7			✓	●	●	●	●			○	24–26	
		1/100			✓									
short version	4,00–16,00	H7			✓	●	●	●	○	○	○		27–32	
	2,96–20,05	1/100			✓									
long version	4,00–16,00	H7			✓	●	●	●	●	○	●	○	33–42	
	2,96–20,05	1/100			✓									
	2,00–30,00	H7				●	○	●	●	○	○	●	43–45	
	0,59–12,05	1/100												
	0,98–12,05	H7				○	○	○			●		46+47	
	2,00–12,00	H7				●	○	●						48
	1,50–20,00	H7				●		●	●			●	49+50	
	0,95–12,00	1/100												
	1,00–20,00	H7				●	○	●	●	○		●		51–53
	0,95–12,00	1/100												
	4,00–20,00	H7				●	○	●	●	○		●		54+55
	3,76–12,00	1/100												
	16,00–50,00	H7				●	○	●	●	○		●		56
	3,00–30,00	H7				●	○	●	●	○		●		56

Countersinks Overview

	Tool type	Coating	Hole diameter (mm) Ø DC	Countersinking angle	Steel	Stainless steel	Cast iron	Non-ferrous metals	Heat-resistant	Tempered steel	Non-metal materials	KOMET \ Performance	KOMET \ Standard
				SIG	P	M	K	N	S	H	O		
Indexable Insert Counterbore Tool													
	WPS		10–48	180°	●	●	●	●	●	○	●	57+58	
Insert countersink 60°/90°													
	WPS		16,5–25,5 19,0–37,0	60° 90°	●	●	●	●	●	○	●	59–61	
HSS – Counterbores													
			6,0–20,0	180°	●	●	●	●	○		●		62
Solid Carbide Countersinks													
	N	HPC-TiN	6,3–31,0	90°	●	○	●	●	○	○	○	63	
	N		12,5–25,0	60°	●	○	●	●	○	○			64
	N		10,4–31,0	90°	●	○	●	●	○	○			64
HSS Countersinks													
	N	TiN	4,3–31,0	90°	●	○	●	●	○	○	○	65	
	N		4,3–31,0	90°	●	○	●	●	○		●		66
	N	TiN	5,0–31,0	90°	●	○	●	●	○	○	●		66
	N	TiAlN	5,0–31,0	90°	●	○	●	●	○	○	●		66
	VA	TiAlN	6,3–31,0	90°	○	●	○	○	○	○	●		66
	AL		6,3–31,0	90°	○	○	○	●	○		●		66
			6,3–25,0	60°	●	○	●	●	○		●		67
	N		30,0–80,0	90°	●	○	●	●	○		●		67
			6,3–25,0	120°	●	○	●	●	○		●		68
Deburring Countersink													
			6,3–28,0	90°	●	○	●	●	○		●		68
		TiN	6,3–28,0	90°	●	○	●	●	○	○	●		68

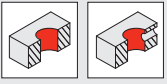
REAMAX TS – Selection guide

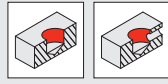
Ø 18 – 65 mm										
Article no.	40 597 ...	40 544 ...	40 577 ...	40 521 ...	40 526 ...	40 539 ...	40 585 ...	40 571 ...	40 580 ...	
KOMET no.	75J.93	75J.93	75J.65	75J.65	75J.17	75H.93	75H.65	75H.65	75H.17	
Cutting edge geometry	ASG4000	ASG3000	ASG3000	ASG0106	ASG0706	ASG3000	ASG3000	ASG0106	ASG0706	
Lead angle	25°	45°	45°	45°	45°/8°	45°	45°	45°	45°/8°	
Grade / coating	DST	DST	DBG-P	DBG-P	DBC	DST	DBG-P	DBG-P	DBC	
Preferred type available	✓	✓	✓	✓	✓	✓	✓	✓		
Application	Through hole					Blind hole				
Material sub-group	Index									
P	Non alloyed steel	P.1.1	●	●	●		●	●		
		P.1.2	●	●	●		●	●		
		P.1.3	●	●	●		●	●		
		P.1.4	●	●	●		●	●		
		P.1.5	●	●	●		●	●		
	Low alloyed steel	P.2.1	●	●	●		●	●		
		P.2.2	●	●	●		●	●		
		P.2.3	●	●	●		●	●		
		P.2.4	●	●	●		●	●		
	High-alloy steel and high-alloy tool steel	P.3.1				●			●	
		P.3.2				●			●	
		P.3.3				●			●	
	Stainless steel	P.4.1				●			●	
		P.4.2				●			●	
M	Stainless steel	M.1.1				●			●	
		M.2.1				●			●	
		M.3.1				●			●	
K	Grey cast iron	K.1.1			●			●		
		K.1.2			●			●		
	Spherulitic graphite cast iron	K.2.1	●	●	●		●	●		
		K.2.2	●	●	●		●	●		
	Malleable iron	K.3.1		●	●		●	●		
		K.3.2	●	●	●		●	●		
N	Aluminum alloys	N.1.1				●			●	
		N.1.2				●			●	
	Cast Aluminium Alloys	N.2.1				●			●	
		N.2.2				●			●	
		N.2.3				●			●	
	Copper and copper alloys (Bronze, Brass)	N.3.1		○			○			
		N.3.2		○			○			
		N.3.3								
Magnesium alloys	N.4.1				●			●		
O	Non-metal materials	O.1.1								
		O.1.2								
		O.2.1								
		O.2.2								
		O.3.1					○			○

● = Main application
○ = Additional range of application

REAMAX TS – Replaceable reaming heads

- ▲ Up to tolerance class IT 6 with absolute process security, from the first hole
- ▲ Maximum changeover precision guaranteed
- ▲ High precision grind for maximum quality
- ▲ Can be adjusted for the smallest hole tolerances

- ▲ Interface enables head change in the machine
- ▲ Retraction from the hole at 3-4x feed rate
- ▲ KLG = Coupling size

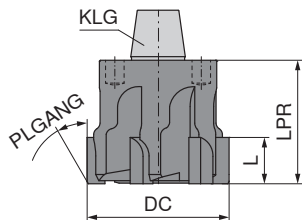

DC _{H7} mm	L mm	LPR mm	ZEFP	KLG	40 597 ...		40 521 ...		40 526 ...		40 577 ...		40 544 ...	
					£ U3/4E	18000	£ U3/4E	18000	£ U3/4E	18000	£ U3/4E	18000	£ U3/4E	18000
18,00	6	20	6	1	391.20	18000	391.20	18000	391.20	18000	391.20	18000	391.20	18000
18,01 - 19,99	6	20	6	1	838.52	xxxx ¹⁾	838.52	xxxx ¹⁾	838.52	xxxx ¹⁾	838.52	xxxx ¹⁾	838.52	xxxx ¹⁾
20,00	6	20	6	2	401.19	20000	401.19	20000	401.19	20000	401.19	20000	401.19	20000
20,01 - 21,99	6	20	6	2	983.12	xxxx ¹⁾	983.12	xxxx ¹⁾	983.12	xxxx ¹⁾	983.12	xxxx ¹⁾	983.12	xxxx ¹⁾
22,00	6	20	6	3	408.66	22000	408.66	22000	408.66	22000	408.66	22000	408.66	22000
22,01 - 23,99	6	20	6	3	1,022.77	xxxx ¹⁾	1,022.77	xxxx ¹⁾	1,022.77	xxxx ¹⁾	1,022.77	xxxx ¹⁾	1,022.77	xxxx ¹⁾
24,00	6	20	6	3	421.10	24000	421.10	24000	421.10	24000	421.10	24000	421.10	24000
24,01 - 24,99	6	20	6	3	1,022.77	xxxx ¹⁾	1,022.77	xxxx ¹⁾	1,022.77	xxxx ¹⁾	1,022.77	xxxx ¹⁾	1,022.77	xxxx ¹⁾
25,00	6	20	6	3	421.10	25000	421.10	25000	421.10	25000	421.10	25000	421.10	25000
25,01 - 25,99	6	20	6	3	1,022.77	xxxx ¹⁾	1,022.77	xxxx ¹⁾	1,022.77	xxxx ¹⁾	1,022.77	xxxx ¹⁾	1,022.77	xxxx ¹⁾
26,00	6	20	6	3	437.31	26000	437.31	26000	1,022.77	26000	437.31	26000	437.31	26000
26,01 - 26,99	6	20	6	3	1,022.77	xxxx ¹⁾	1,022.77	xxxx ¹⁾	1,022.77	xxxx ¹⁾	1,022.77	xxxx ¹⁾	1,022.77	xxxx ¹⁾
27,00 - 27,99	6	25	6	4	1,065.15	xxxx ¹⁾	1,065.15	xxxx ¹⁾	1,065.15	xxxx ¹⁾	1,065.15	xxxx ¹⁾	1,065.15	xxxx ¹⁾
28,00	6	25	6	4	437.31	28000	437.31	28000	437.31	28000	437.31	28000	437.31	28000
28,01 - 29,99	6	25	6	4	1,065.15	xxxx ¹⁾	1,065.15	xxxx ¹⁾	1,065.15	xxxx ¹⁾	1,065.15	xxxx ¹⁾	1,065.15	xxxx ¹⁾
30,00	6	25	6	4	457.23	30000	457.23	30000	457.23	30000	457.23	30000	457.23	30000
30,01 - 31,79	6	25	6	4	1,065.15	xxxx ¹⁾	1,065.15	xxxx ¹⁾	1,065.15	xxxx ¹⁾	1,065.15	xxxx ¹⁾	1,065.15	xxxx ¹⁾
31,80 - 31,99	6	25	8	4	1,113.42	xxxx ¹⁾	1,113.42	xxxx ¹⁾	1,113.42	xxxx ¹⁾	1,113.42	xxxx ¹⁾	1,113.42	xxxx ¹⁾
32,00	6	25	8	4	473.44	32000	473.44	32000	473.44	32000	473.44	32000	473.44	32000
32,01 - 34,99	6	25	8	4	1,113.42	xxxx ¹⁾	1,113.42	xxxx ¹⁾	1,113.42	xxxx ¹⁾	1,113.42	xxxx ¹⁾	1,113.42	xxxx ¹⁾
35,00	6	25	8	5	495.85	35000	495.85	35000	495.85	35000	495.85	35000	495.85	35000
35,01 - 39,99	6	25	8	5	1,218.11	xxxx ¹⁾	1,218.11	xxxx ¹⁾	1,218.11	xxxx ¹⁾	1,218.11	xxxx ¹⁾	1,218.11	xxxx ¹⁾
40,00	6	25	8	5	524.51	40000	524.51	40000	524.51	40000	524.51	40000	524.51	40000
40,01 - 41,99	6	25	8	5	1,218.11	xxxx ¹⁾	1,218.11	xxxx ¹⁾	1,218.11	xxxx ¹⁾	1,218.11	xxxx ¹⁾	1,218.11	xxxx ¹⁾
42,00	6	30	8	6	524.51	42000	524.51	42000	1,323.04	42000	524.51	42000	524.51	42000
42,01 - 49,99	6	30	8	6	1,323.04	xxxx ¹⁾	1,323.04	xxxx ¹⁾	1,323.04	xxxx ¹⁾	1,323.04	xxxx ¹⁾	1,323.04	xxxx ¹⁾
50,00	6	30	8	6	536.97	50000	536.97	50000	536.97	50000	536.97	50000	536.97	50000
50,01 - 51,99	6	30	8	6	1,323.04	xxxx ¹⁾	1,323.04	xxxx ¹⁾	1,323.04	xxxx ¹⁾	1,323.04	xxxx ¹⁾	1,323.04	xxxx ¹⁾
52,00 - 53,99	8	35	10	7	1,467.42	xxxx ¹⁾	1,467.42	xxxx ¹⁾	1,467.42	xxxx ¹⁾	1,467.42	xxxx ¹⁾	1,467.42	xxxx ¹⁾
54,00	8	35	10	7	604.25	54000	604.25	54000	1,467.42	54000	604.25	54000	604.25	54000
54,01 - 65,00	8	35	10	7	1,467.42	xxxx ¹⁾	1,467.42	xxxx ¹⁾	1,467.42	xxxx ¹⁾	1,467.42	xxxx ¹⁾	1,467.42	xxxx ¹⁾
P						●		●			●		●	
M														
K						●					●		●	
N										●				○
S														
H														
O														○

1) Not available ex stock, articles are non-returnable and cannot be exchanged / Delivery time on request / Minimum order 2 pieces

i For xxxx please indicate requested Ø in H7 in the order (e.g. Ø 24.12 H7 → article no. 40 597 2412)!
All other diameters and tolerance classes are also possible on request (e.g. 18.5^{+0.025} or 18 N7)!
All heads are also available as fixed head variants (not adjustable) on request.

i Assembly instructions can be found on → **Page 96+97**

i Further information on chamfer geometries (ASG) can be found on → **page 100**.

REAMAX TS – Replaceable reaming heads

- ▲ Up to tolerance class IT 6 with absolute process security, from the first hole
- ▲ Maximum changeover precision guaranteed
- ▲ High precision grind for maximum quality
- ▲ Can be adjusted for the smallest hole tolerances

- ▲ Interface enables head change in the machine
- ▲ Retraction from the hole at 3-4x feed rate
- ▲ KLG = Coupling size

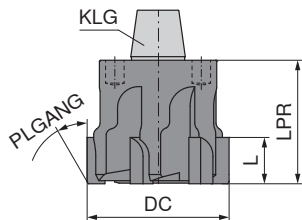

DC _{H7} mm	L mm	LPR mm	ZEFP	KLG	40 539 ...		40 571 ...		40 580 ...		40 585 ...	
					£ U3/4E	18000	£ U3/4E	18000	£ U3/4E	18000 ¹⁾	£ U3/4E	18000
18,00	6	20	6	1	391.20	18000	391.20	18000	838.52	18000 ¹⁾	838.52	18000
18,01 - 19,99	6	20	6	1	838.52	xxxx ¹⁾	838.52	xxxx ¹⁾	838.52	xxxx ¹⁾	838.52	xxxx ¹⁾
20,00	6	20	6	2	401.19	20000	401.19	20000	983.12	20000 ¹⁾	983.12	20000
20,01 - 21,99	6	20	6	2	983.12	xxxx ¹⁾	983.12	xxxx ¹⁾	983.12	xxxx ¹⁾	983.12	xxxx ¹⁾
22,00	6	20	6	3	408.66	22000	408.66	22000	1,022.77	22000 ¹⁾	1,022.77	22000
22,01 - 23,99	6	20	6	3	1,022.77	xxxx ¹⁾	1,022.77	xxxx ¹⁾	1,022.77	xxxx ¹⁾	1,022.77	xxxx ¹⁾
24,00	6	20	6	3	421.10	24000	421.10	24000	1,022.77	24000 ¹⁾	1,022.77	24000
24,01 - 24,99	6	20	6	3	1,022.77	xxxx ¹⁾	1,022.77	xxxx ¹⁾	1,022.77	xxxx ¹⁾	1,022.77	xxxx ¹⁾
25,00	6	20	6	3	421.10	25000	421.10	25000	1,022.77	25000 ¹⁾	1,022.77	25000
25,01 - 25,99	6	20	6	3	1,022.77	xxxx ¹⁾	1,022.77	xxxx ¹⁾	1,022.77	xxxx ¹⁾	1,022.77	xxxx ¹⁾
26,00	6	20	6	3	437.31	26000	437.31	26000	1,022.77	26000 ¹⁾	1,022.77	26000
26,01 - 26,99	6	20	6	3	1,022.77	xxxx ¹⁾	1,022.77	xxxx ¹⁾	1,022.77	xxxx ¹⁾	1,022.77	xxxx ¹⁾
27,00 - 27,99	6	25	6	4	1,065.15	xxxx ¹⁾	1,065.15	xxxx ¹⁾	1,065.15	xxxx ¹⁾	1,065.15	xxxx ¹⁾
28,00	6	25	6	4	437.31	28000	437.31	28000	1,065.15	28000 ¹⁾	1,065.15	28000
28,01 - 29,99	6	25	6	4	1,065.15	xxxx ¹⁾	1,065.15	xxxx ¹⁾	1,065.15	xxxx ¹⁾	1,065.15	xxxx ¹⁾
30,00	6	25	6	4	457.23	30000	457.23	30000	1,065.15	30000 ¹⁾	1,065.15	30000
30,01 - 31,79	6	25	6	4	1,065.15	xxxx ¹⁾	1,065.15	xxxx ¹⁾	1,065.15	xxxx ¹⁾	1,065.15	xxxx ¹⁾
31,80 - 31,99	6	25	8	4	1,113.42	xxxx ¹⁾	1,113.42	xxxx ¹⁾	1,113.42	xxxx ¹⁾	1,113.42	xxxx ¹⁾
32,00	6	25	8	4	473.44	32000	473.44	32000	1,113.42	32000 ¹⁾	1,113.42	32000
32,01 - 34,99	6	25	8	4	1,113.42	xxxx ¹⁾	1,113.42	xxxx ¹⁾	1,113.42	xxxx ¹⁾	1,113.42	xxxx ¹⁾
35,00	6	25	8	5	495.85	35000	495.85	35000	1,218.11	35000 ¹⁾	1,218.11	35000
35,01 - 39,99	6	25	8	5	1,218.11	xxxx ¹⁾	1,218.11	xxxx ¹⁾	1,218.11	xxxx ¹⁾	1,218.11	xxxx ¹⁾
40,00	6	25	8	5	524.51	40000	524.51	40000	1,218.11	40000 ¹⁾	1,218.11	40000
40,01 - 41,99	6	25	8	5	1,218.11	xxxx ¹⁾	1,218.11	xxxx ¹⁾	1,218.11	xxxx ¹⁾	1,218.11	xxxx ¹⁾
42,00	6	30	8	6	524.51	42000	524.51	42000	1,323.04	42000 ¹⁾	1,323.04	42000
42,01 - 49,99	6	30	8	6	1,323.04	xxxx ¹⁾	1,323.04	xxxx ¹⁾	1,323.04	xxxx ¹⁾	1,323.04	xxxx ¹⁾
50,00	6	30	8	6	536.97	50000	536.97	50000	1,323.04	50000 ¹⁾	1,323.04	50000
50,01 - 51,99	6	30	8	6	1,323.04	xxxx ¹⁾	1,323.04	xxxx ¹⁾	1,323.04	xxxx ¹⁾	1,323.04	xxxx ¹⁾
52,00 - 53,99	8	35	10	7	1,467.42	xxxx ¹⁾	1,467.42	xxxx ¹⁾	1,467.42	xxxx ¹⁾	1,467.42	xxxx ¹⁾
54,00	8	35	10	7	604.25	54000 ¹⁾	604.25	54000 ¹⁾	1,467.42	54000 ¹⁾	1,467.42	54000 ¹⁾
54,01 - 65,00	8	35	10	7	1,467.42	xxxx ¹⁾	1,467.42	xxxx ¹⁾	1,467.42	xxxx ¹⁾	1,467.42	xxxx ¹⁾
P						●		●				●
M												
K						●						●
N						○				●		
S												
H												
O												○

1) Not available ex stock, articles are non-returnable and cannot be exchanged / Delivery time on request / Minimum order 2 pieces

i For xxxx please indicate requested Ø in H7 in the order (e.g. Ø 24.12 H7 → article no. 40 539 2412)!
All other diameters and tolerance classes are also possible on request (e.g. 18.5^{+0.025} or 18 N7)!
All heads are also available as fixed head variants (not adjustable) on request.

i Assembly instructions can be found on → **Page 96+97**

i Further information on chamfer geometries (ASG) can be found on → **page 100**.

REAMAX TS – Holder

▲ KLG = Coupling Size

Scope of supply:

Complete holder incl. pull stud but without exchangeable head

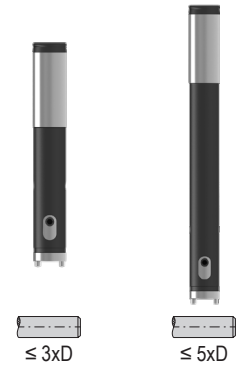
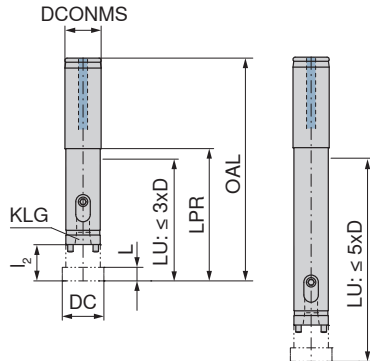

DC mm	KOMET no.	KLG	OAL mm	l ₂ mm	LPR mm	L mm	DCONMS mm	torque moment Nm	40 501 ...		40 503 ...	
									£ U3/4E		£ U3/4E	
18,00 - 19,99	75A.40.13010	1	130	20	80	6	20	1,5	418.99	02099		
18,00 - 19,99	75A.40.15010	1	190	20	140	6	20	1,5			434.57	02099
20,00 - 21,99	75A.40.13020	2	130	20	80	6	20	2,5	434.57	02299		
20,00 - 21,99	75A.40.15020	2	190	20	140	6	20	2,5			453.25	02299
22,00 - 26,99	75A.40.13030	3	130	20	80	6	20	4	445.40	02799		
22,00 - 26,99	75A.40.15030	3	210	20	160	6	20	4			478.17	02799
27,00 - 34,99	75A.40.13040	4	176	25	120	6	25	5	462.60	03599		
27,00 - 34,99	75A.40.15040	4	236	25	180	6	25	5			492.13	03599
35,00 - 41,99	75A.40.13050	5	176	25	120	6	25	6	528.00	04299		
35,00 - 41,99	75A.40.15050	5	256	25	200	6	25	6			557.07	04299
42,00 - 51,99	75A.40.13060	6	180	30	120	6	32	10	545.08	05299		
42,00 - 51,99	75A.40.15060	6	280	30	220	6	32	10			575.09	05299
52,00 - 65,00	75A.40.13070	7	180	30	120	8	32	13	562.27	06599		
52,00 - 65,00	75A.40.15070	7	280	30	220	8	32	13			593.22	06599

Do not heat shrink tools !

Spare parts DC		80 397 ...		80 950 ...		40 900 ...	
		£ Y7		£ Y7		£ U3/4E	
18,00 - 19,99						17.44	00100
20,00 - 21,99	SW2,5	6.30	025			17.44	00200
22,00 - 26,99	SW3	6.07	030			17.44	00300
27,00 - 34,99	SW3	6.07	030			17.44	00400
35,00 - 41,99	SW3	6.07	030			24.18	00500
42,00 - 51,99	SW4	6.07	040			24.18	00500
52,00 - 65,00	SW5	7.73	050			24.18	00700

Assembly instructions can be found on → Page 96+97

REAMAX TS – Holder

- ▲ KLG = Coupling size
- ▲ Adjustment inside the machine
- ▲ Alignable DAH Zero holder for correction of concentricity error
- ▲ DAH Zero holder is pre-loaded and set to a runout of < 0.005 mm

Scope of supply:

Complete holder incl. pull stud but without exchangeable head

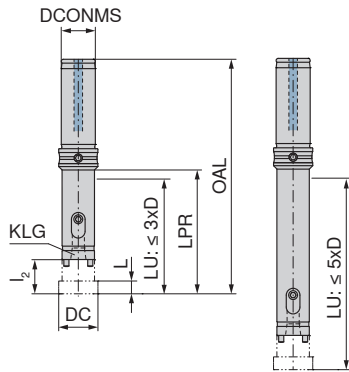







DC mm	KOMET no.	KLG	OAL mm	l ₂ mm	LPR mm	L mm	DCONMS mm	torque moment Nm	40 504 ...		40 506 ...	
									£		£	
18,00 - 19,99	75A.41.13010	1	145	20	80	6	20	1,5	562.27	02099	598.03	02099
18,00 - 19,99	75A.41.15010	1	205	20	140	6	20	1,5			616.72	02299
20,00 - 21,99	75A.41.13020	2	145	20	80	6	20	2,5	568.49	02299	633.91	02799
20,00 - 21,99	75A.41.15020	2	205	20	140	6	20	2,5			633.91	03599
22,00 - 26,99	75A.41.13030	3	145	20	80	6	20	4	582.46	02799	744.42	04299
22,00 - 26,99	75A.41.15030	3	225	20	160	6	20	4			758.50	04299
27,00 - 34,99	75A.41.13040	4	176	25	120	6	25	5	612.11	03599		
27,00 - 34,99	75A.41.15040	4	236	25	180	6	25	5				
35,00 - 41,99	75A.41.13050	5	176	25	120	6	25	6	744.42	04299		
35,00 - 41,99	75A.41.15050	5	256	25	200	6	25	6				

i Do not heat shrink tools !

Spare parts DC		80 397 ...		80 950 ...		40 900 ...	
		£		£		£	
18,00 - 19,99		Y7		Y7		U3/4E	
20,00 - 21,99	SW2,5	6.30	025	11.08	039	17.44	00100
22,00 - 26,99	SW3	6.07	030			17.44	00200
27,00 - 34,99	SW3	6.07	030			17.44	00400
35,00 - 41,99	SW3	6.07	030			24.18	00500

i Assembly instructions can be found on → Page 96+97

REAMAX – Selection guide

Ø 12,5 – 40 mm								
Article no.	40 536 ...	40 525 ...	40 560 ...	40 551 ...	40 570 ...	40 505 ...		
KOMET no.	640.93	640.93	640.65	640.65	640.27	640.71		
Cutting edge geometry	ASG4000	ASG3000	ASG3000	ASG0106	ASG0706	ASG3000		
Lead angle	25°	45°	45°	45°	45°/8°	45°		
Grade / coating	DST	DST	DBG-P	DBG-P	DBC	TiN		
Preferred type available	✓	✓	✓	✓		✓		
Application	Through hole		Through hole + blind hole					
Material sub-group	Index							
P	Non alloyed steel	P.1.1	●	●	●			○
		P.1.2	●	●	●			○
		P.1.3	●	●	●			○
		P.1.4	●	●	●			○
		P.1.5	●	●	●			○
	Low alloyed steel	P.2.1	●	●	●			○
		P.2.2	●	●	●			○
		P.2.3	●	●	●			○
		P.2.4			●	●		○
	High-alloy steel and high-alloy tool steel	P.3.1				●		
		P.3.2				●		
		P.3.3				●		
	Stainless steel	P.4.1				●		
		P.4.2				●		
M	Stainless steel	M.1.1				●		
		M.2.1				●		
		M.3.1				●		
K	Grey cast iron	K.1.1			●		○	
		K.1.2			●		○	
	Spherulitic graphite cast iron	K.2.1	○	●	●			
		K.2.2	○	●	●			
	Malleable iron	K.3.1		●	●			
		K.3.2	○	●	●			
N	Aluminum alloys	N.1.1				●		
		N.1.2				●		
	Cast aluminium alloys	N.2.1				●		
		N.2.2				●		
		N.2.3						
	Copper and copper alloys (Bronze, Brass)	N.3.1		○				●
		N.3.2		○				●
		N.3.3						●
Magnesium alloys	N.4.1							
H	Hardened steel	H.1.1				●		
		H.1.2				●		
		H.1.3				●		
		H.1.4						
	Chilled iron	H.2.1				●		
	Hardened cast iron	H.3.1				●		
O	Non-metal materials	O.1.1						
		O.1.2						
		O.2.1						
		O.2.2						
		O.3.1					○	

● = Main application
○ = Additional range of application

REAMAX – Replaceable reaming heads

- ▲ Up to tolerance class IT 7 with absolute process security, from the first hole
- ▲ Maximum changeover precision guaranteed
- ▲ Maximum radial run-out accuracy thanks to precision-ground face and taper contact
- ▲ No Ø adjustment necessary

- ▲ Optimised for use with minimum quantity lubrication (MQL)
- ▲ Retraction from the hole at 3-4x feed rate
- ▲ KLG = Coupling size

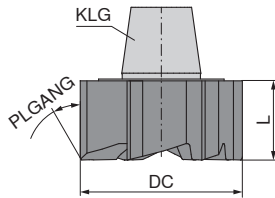

DST	DBG-P	DBC	DST	DBG-P	TiN
640.93 PLGANG 25° ASG4000 CERMET Through hole	640.65 PLGANG 45° ASG0106 HM Through hole + blind hole	640.27 PLGANG 45/8° ASG0706 HM Through hole + blind hole	640.93 PLGANG 45° ASG3000 CERMET Through hole + blind hole	640.65 PLGANG 45° ASG3000 HM Through hole + blind hole	640.71 PLGANG 45° ASG3000 HM Through hole + blind hole

DC _{H7} mm	L mm	ZEFP	KLG	40 536 ...		40 551 ...		40 570 ...		40 525 ...		40 560 ...		40 505 ...	
				£		£		£		£		£		£	
12,50 - 14,99	9	6	1	583.58	xxxx ¹⁾	583.58	xxxx ¹⁾	583.58	xxxx ¹⁾	583.58	xxxx ¹⁾	583.58	xxxx ¹⁾	583.58	xxxx ¹⁾
15,00	9	6	1	277.29	15000 ¹⁾	265.38	15000	265.38	15000 ¹⁾	277.29	15000 ¹⁾	265.38	15000	485.56	150
15,01 - 15,99	9	6	1	583.58	xxxx ¹⁾	583.58	xxxx ¹⁾	583.58	xxxx ¹⁾	583.58	xxxx ¹⁾	583.58	xxxx ¹⁾	583.58	xxxx ¹⁾
16,00	9	6	2	558.50	160	305.24	16000	305.24	16000 ¹⁾	558.50	160	305.24	16000	558.50	160
16,01 - 17,99	9	6	2	665.84	xxxx ¹⁾	665.84	xxxx ¹⁾	665.84	xxxx ¹⁾	665.84	xxxx ¹⁾	665.84	xxxx ¹⁾	665.84	xxxx ¹⁾
18,00	9	6	2	565.34	180	308.98	18000	308.98	18000 ¹⁾	565.34	180	308.98	18000	565.34	180
18,01 - 19,99	9	6	2	665.84	xxxx ¹⁾	665.84	xxxx ¹⁾	665.84	xxxx ¹⁾	665.84	xxxx ¹⁾	665.84	xxxx ¹⁾	665.84	xxxx ¹⁾
20,00	9	6	2	576.74	200	315.21	20000	315.21	20000 ¹⁾	576.74	200	315.21	20000	576.74	200
20,01 - 21,99	9	6	2	665.84	xxxx ¹⁾	665.84	xxxx ¹⁾	665.84	xxxx ¹⁾	665.84	xxxx ¹⁾	665.84	xxxx ¹⁾	665.84	xxxx ¹⁾
22,00	9	8	3	590.43	220	322.69	22000	322.69	22000 ¹⁾	590.43	220	322.69	22000	590.43	220
22,01 - 23,99	9	8	3	719.54	xxxx ¹⁾	719.54	xxxx ¹⁾	719.54	xxxx ¹⁾	719.54	xxxx ¹⁾	719.54	xxxx ¹⁾	719.54	xxxx ¹⁾
24,00	9	8	3	348.81	24000 ¹⁾	333.89	24000	333.89	24000 ¹⁾	348.81	24000 ¹⁾	333.89	24000	610.94	240
24,01 - 24,99	9	8	3	719.54	xxxx ¹⁾	719.54	xxxx ¹⁾	719.54	xxxx ¹⁾	719.54	xxxx ¹⁾	719.54	xxxx ¹⁾	719.54	xxxx ¹⁾
25,00	9	8	3	636.01	250	347.62	25000	347.62	25000 ¹⁾	636.01	250	347.62	25000	636.01	250
25,01 - 25,99	9	8	3	719.54	xxxx ¹⁾	719.54	xxxx ¹⁾	719.54	xxxx ¹⁾	719.54	xxxx ¹⁾	719.54	xxxx ¹⁾	719.54	xxxx ¹⁾
26,00 - 27,99	9	8	4	824.47	xxxx ¹⁾	824.47	xxxx ¹⁾	824.47	xxxx ¹⁾	824.47	xxxx ¹⁾	824.47	xxxx ¹⁾	824.47	xxxx ¹⁾
28,00	9	8	4	658.81	280	360.07	28000	360.07	28000 ¹⁾	658.81	280	360.07	28000	658.81	280
28,01 - 29,99	9	8	4	824.47	xxxx ¹⁾	824.47	xxxx ¹⁾	824.47	xxxx ¹⁾	824.47	xxxx ¹⁾	824.47	xxxx ¹⁾	824.47	xxxx ¹⁾
30,00	9	8	4	690.72	300	377.50	30000	377.50	30000 ¹⁾	690.72	300	377.50	30000	690.72	300
30,01 - 32,00	9	8	4	824.47	xxxx ¹⁾	824.47	xxxx ¹⁾	824.47	xxxx ¹⁾	824.47	xxxx ¹⁾	824.47	xxxx ¹⁾	824.47	xxxx ¹⁾
32,01 - 39,99	9	8	5	934.84	xxxx ¹⁾	934.84	xxxx ¹⁾	934.84	xxxx ¹⁾	934.84	xxxx ¹⁾	934.84	xxxx ¹⁾	934.84	xxxx ¹⁾
40,00	9	8	5	731.75	400	399.92	40000	399.92	40000 ¹⁾	731.75	400	399.92	40000	731.75	400

P	●	●	●	○
M		●		
K	○		●	○
N			●	●
S				
H		●		
O			○	

1) Not available ex stock, articles are non-returnable and cannot be exchanged / Delivery time on request / Minimum order 2 pieces

For xxxx please indicate requested Ø in H7 in the order (e.g. Ø 15.12 H7 → article no. 40 525 1512)!
All other diameters and tolerance classes are also possible on request (e.g. 18.5^{+0.025} or 18 N7)!

A detailed operating manual is available for download in the online shop next to the product.

Further information on chamfer geometries (ASG) can be found on → page 100.

REAMAX – Holder

▲ KLG = Coupling Size

Scope of supply:

Complete holder, but without exchangeable head

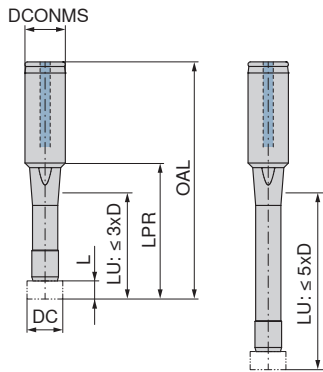

DC mm	KOMET no.	KLG	OAL mm	LPR mm	L mm	DCONMS mm	torque moment Nm	40 590 ... £ U3/4E	40 591 ... £ U3/4E
12,50 - 15,99	640.01.001	1	107	59	9	16	4 - 5	757.99	016
12,50 - 15,99	640.81.001	1	137	89	9	16	4 - 5	757.99	016
16,00 - 21,99	640.01.002	2	119	69	9	20	6 - 7	792.16	022
16,00 - 21,99	640.81.002	2	169	119	9	20	6 - 7	792.16	022
22,00 - 25,99	640.01.003	3	140	84	9	25	10 - 12	843.45	026
22,00 - 25,99	640.81.003	3	196	140	9	25	10 - 12	843.45	026
26,00 - 32,00	640.01.005	4	160	104	9	25	18 - 20	871.94	032
26,00 - 32,00	640.81.005	4	226	170	9	25	18 - 20	871.94	032
32,01 - 40,00	640.01.006	5	199	139	9	32	26 - 28	997.34	040
32,01 - 40,00	640.81.006	5	270	210	9	32	26 - 28	997.34	040

1) This holder can also be used for reaming heads for through holes from Ø 12 mm, which are available on request

Do not heat shrink tools !

Spare parts DC	DCONMS	40 950 ...		40 950 ...		40 950 ...		40 950 ...	
		£ U3/4E		£ U3/4E		£ U3/4E		£ U3/4E	
12,50 - 15,99	16			103.27	101	262.15	001	1.24	301
12,50 - 15,99	16	105.67	107			262.15	001	1.24	301
16,00 - 21,99	20	105.67	108			262.15	002	1.24	302
16,00 - 21,99	20			103.27	102	262.15	002	1.24	302
22,00 - 25,99	25			120.82	103	273.56	003	1.24	303
22,00 - 25,99	25	124.43	109			273.56	003	1.24	303
26,00 - 32,00	25			139.06	104	287.92	004	1.24	303
26,00 - 32,00	25	143.22	110			287.92	004	1.24	303
32,01 - 40,00	32	162.02	112			310.71	005	1.24	304
32,01 - 40,00	32			157.29	106	310.71	005	1.24	304

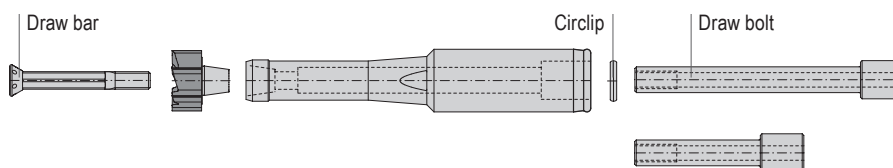

A detailed operating manual is available for download in the online shop next to the product.

MultiChange – Programme Overview

The "MultiChange" interchangeable head system enables an extremely fast and problem free tool change. Provides quick changeover and concentricity with the highest stability at the same time. For a multitude of applications, the suitable interchangeable heads are available in the following chapters.

Exchangeable heads	
<p>→ Chapter 2, Solid carbide drilling</p> <p>Solid Carbide NC Spot Drills</p> <p>Ø 8, 10, 12, 16, 20 mm NOF 2</p> <p>SIG 90° SIG 120° SIG 142°</p>	<p>Page No. 2 105</p>
<p>→ Chapter 4, Reaming and countersinking</p> <p>Replaceable reaming heads</p> <p>Ø 8,00 – 30,20 mm</p> <p>Through hole</p> <p>Ø 12,20 – 30,20 mm</p> <p>Blind hole</p>	<p>Page No. 4 18 + 4 19</p>
<p>→ Chapter 14, Solid carbide milling cutters</p> <p>Solid carbide shoulder mills</p> <p>Ø 8, 10, 12, 16, 20 mm / ZEFP 3+4</p> <p>Type PCR-UNI Type PCR-ALU Type N</p> <p>Solid carbide torus bull nose milling cutters</p> <p>Ø 8, 10, 12, 16, 20 mm / ZEFP 3+4</p> <p>Type W Type N</p> <p>Solid carbide rough and finish milling cutters</p> <p>Ø 8, 10, 12, 16, 20 mm / ZEFP 4+6</p> <p>Type NF</p> <p>Solid carbide finish milling cutters</p> <p>Ø 8, 10, 12, 16, 20 mm / ZEFP 6</p> <p>Type N</p> <p>Solid carbide ball-nosed end mills</p> <p>Ø 10, 12, 16, 20 mm / ZEFP 4</p> <p>Type N</p> <p>Solid carbide high-feed cutters</p> <p>Ø 8, 10, 12, 16, 20 mm / ZEFP 6</p> <p>Type N</p> <p>Solid carbide quarter round cutter</p> <p>Ø 8, 10, 12, 16, 20 mm / ZEFP 6</p> <p>Type N</p> <p>Solid carbide deburring cutters</p> <p>Ø 10, 12, 16, 20 mm / ZEFP 4+6</p> <p>Type N Type N</p>	<p>Page No. 14 197 – 14 201</p>

NOF / ZEFP = Number of cutting edges

Tool holder
<p>→ Catalogue – Clamping technology, Chapter 16 Accessories</p> <p>Page No. 16 253 – 16 255</p> <p>extra short / OAL 60 – 90 mm</p> <p>Tapered 87° / Steel Cylindrical* / Steel</p> <p>short / OAL 85 – 120 mm</p> <p>Tapered 87° / Steel Cylindrical* / Steel</p> <p>Tapered 87° / Solid carbide Cylindrical* / Solid carbide</p> <p>medium / OAL 110 – 150 mm</p> <p>Tapered 87° / Solid carbide</p> <p>Cylindrical* / Solid carbide</p> <p>long / OAL 150 – 200 mm</p> <p>Tapered 87° / Solid carbide</p> <p>Cylindrical* / Steel</p> <p>Cylindrical* / Solid carbide</p> <p>extra long / OAL 200 – 250 mm</p> <p>Cylindrical* / Steel</p> <p>Cylindrical* / Solid carbide</p>

* only conditionally suitable for milling

MultiChange – Reaming Head, for Thro' Holes

- ▲ Up to tolerance class IT 7 with absolute process security, from the first hole
- ▲ High-speed reaming heads
- ▲ Irregular pitch for highest radial run-out accuracy
- ▲ A high level of changeover precision guaranteed
- ▲ SZID = Coupling size

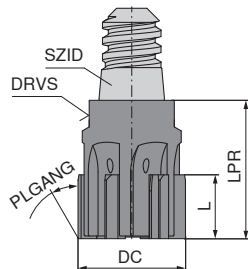

Left Hand Helix PLGANG 30° CERMET Through hole
 Left Hand Helix PLGANG 30° HM Through hole
 straight flute PLGANG 45° Solid carbide Through hole

DC _{H7} mm	SZID	L mm	LPR mm	ZEFP	DRVS mm	TQX Nm
8,00	06	8	18	4	6	5.0
8,01 - 9,70	06	8	18	4	6	5.0
9,71 - 9,99	06	8	18	6	8	5.0
10,00	06	8	18	6	8	5.0
10,01 - 10,70	06	8	18	6	8	5.0
10,71 - 11,99	08	8	20	6	8	12.5
12,00	08	8	20	6	8	12.5
12,01 - 12,70	08	8	20	6	8	12.5
12,71 - 13,99	10	8	22	6	10	15.0
14,00	10	8	22	6	10	15.0
14,01 - 15,99	10	8	22	6	10	15.0
16,00	10	8	22	6	10	15.0
16,01 - 16,20	10	8	22	6	10	15.0
16,21 - 17,20	10	8	22	6	13	15.0
17,21 - 17,99	12	12	26	6	13	20.0
18,00	12	12	26	6	13	20.0
18,01 - 19,20	12	12	26	6	13	20.0
19,21 - 19,99	12	12	26	6	16	20.0
20,00	12	12	26	6	16	20.0
20,01 - 20,20	12	12	26	6	16	20.0
20,21 - 21,20	12	12	26	6	16	20.0
21,21 - 21,99	16	12	26	6	16	25.0
22,00	16	12	26	6	16	25.0
22,01 - 23,99	16	12	26	6	16	25.0
24,00	16	12	26	6	16	25.0
24,01 - 24,20	16	12	26	6	16	25.0
24,21 - 24,99	16	12	26	6	19	25.0
25,00	16	12	26	6	19	25.0
25,01 - 25,99	16	12	26	6	19	25.0
26,00	16	12	26	6	19	25.0
26,01 - 26,20	16	12	26	6	19	25.0
26,21 - 27,99	16	12	26	6	21	25.0
28,00	16	12	26	6	21	25.0
28,01 - 28,20	16	12	26	6	21	25.0
28,21 - 29,20	16	12	26	6	24	25.0
29,21 - 29,99	16	12	26	8	24	25.0
30,00	16	12	26	8	24	25.0
30,01 - 30,20	16	12	26	8	24	25.0

40 210 ...		40 220 ...		40 240 ...	
£		£		£	
U3		U3		U3	
338.88	080	338.88	080	305.43	080 ¹⁾
367.86	xxxx ¹⁾	367.86	xxxx ²⁾	332.18	xxxx ¹⁾
416.91	xxxx ¹⁾	416.91	xxxx ²⁾	374.53	xxxx ¹⁾
383.44	100	383.44	100	345.57	100 ¹⁾
416.91	xxxx ¹⁾	416.91	xxxx ²⁾	374.53	xxxx ¹⁾
416.91	xxxx ¹⁾	416.91	xxxx ²⁾	374.53	xxxx ¹⁾
383.44	120	383.44	120	345.57	120 ¹⁾
416.91	xxxx ¹⁾	416.91	xxxx ²⁾	374.53	xxxx ¹⁾
443.65	xxxx ¹⁾	443.65	xxxx ²⁾	399.08	xxxx ¹⁾
407.97	140	407.97	140	367.86	140 ¹⁾
443.65	xxxx ¹⁾	443.65	xxxx ²⁾	399.08	xxxx ¹⁾
407.97	160	407.97	160	367.86	160 ¹⁾
443.65	xxxx ¹⁾	443.65	xxxx ²⁾	399.08	xxxx ¹⁾
443.65	xxxx ¹⁾	443.65	xxxx ²⁾	399.08	xxxx ¹⁾
463.72	xxxx ¹⁾	463.72	xxxx ²⁾	416.91	xxxx ¹⁾
425.85	180	425.85	180	383.44	180 ¹⁾
463.72	xxxx ¹⁾	463.72	xxxx ²⁾	416.91	xxxx ¹⁾
463.72	xxxx ¹⁾	463.72	xxxx ²⁾	416.91	xxxx ¹⁾
425.85	200	425.85	200	383.44	200 ¹⁾
463.72	xxxx ¹⁾	463.72	xxxx ²⁾	416.91	xxxx ¹⁾
483.78	xxxx ¹⁾	483.78	xxxx ²⁾	434.73	xxxx ¹⁾
483.78	xxxx ¹⁾	483.78	xxxx ²⁾	434.73	xxxx ¹⁾
445.89	220	445.89	220	399.08	220 ¹⁾
483.78	xxxx ¹⁾	483.78	xxxx ²⁾	434.73	xxxx ¹⁾
445.89	240	445.89	240	399.08	240 ¹⁾
483.78	xxxx ¹⁾	483.78	xxxx ²⁾	434.73	xxxx ¹⁾
517.22	xxxx ¹⁾	517.22	xxxx ²⁾	465.96	xxxx ¹⁾
474.85	250	474.85	250	428.03	250 ¹⁾
517.22	xxxx ¹⁾	517.22	xxxx ²⁾	465.96	xxxx ¹⁾
474.85	260	474.85	260	428.03	260 ¹⁾
517.22	xxxx ¹⁾	517.22	xxxx ²⁾	465.96	xxxx ¹⁾
517.22	xxxx ¹⁾	517.22	xxxx ²⁾	465.96	xxxx ¹⁾
474.85	280	474.85	280	428.03	280 ¹⁾
517.22	xxxx ¹⁾	517.22	xxxx ²⁾	465.96	xxxx ¹⁾
572.95	xxxx ¹⁾	572.95	xxxx ²⁾	514.99	xxxx ¹⁾
572.95	xxxx ¹⁾	572.95	xxxx ²⁾	514.99	xxxx ¹⁾
526.15	300	526.15	300	474.85	300 ¹⁾
572.95	xxxx ¹⁾	572.95	xxxx ²⁾	514.99	xxxx ¹⁾

P	●	●
M		●
K	●	
N		●
S		
H		
O		

1) Not available ex stock, articles are non-returnable and cannot be exchanged / Delivery time 12 working days / Minimum order 2 pieces
 2) Not available ex stock, articles are non-returnable and cannot be exchanged / Delivery time 23 working days / Minimum order 2 pieces

For xxxx please indicate requested diameter in H7 in the order (e.g. 10.89 H7 → article no. 40 210 1089)!
 All other diameters and tolerance classes are also possible on request (e.g. 8.5^{+0.025} or 11 N7).

Holders and accessories can be found in → **Catalogue – Clamping technology, Chapter 16.**

MultiChange – Reaming Head, for blind holes

- ▲ Up to tolerance class IT 7 with absolute process security, from the first hole
- ▲ High-speed reaming heads
- ▲ Irregular pitch for highest radial run-out accuracy
- ▲ A high level of changeover precision guaranteed
- ▲ SZID = Coupling size

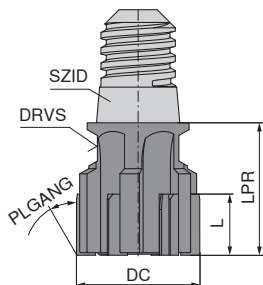

straight flute PLGANG 60° CERMET Blind hole	straight flute PLGANG 60° HM Blind hole	straight flute PLGANG 60° Solid carbide Blind hole
--	--	---



DC H7 mm	SZID	L mm	LPR mm	ZEFP	DRVS mm	TQX Nm	40 211 ...		40 221 ...		40 241 ...	
							£ U3	xxxx ¹⁾	£ U3	xxxx ²⁾	£ U3	xxxx ¹⁾
12,20 - 12,70	06	8	20	6	6	5.0	416.91	xxxx ¹⁾	416.91	xxxx ²⁾	374.53	xxxx ¹⁾
12,71 - 13,99	06	8	22	6	6	5.0	443.65	xxxx ¹⁾	443.65	xxxx ²⁾	399.08	xxxx ¹⁾
14,00	06	8	22	6	6	5.0	407.97	140	407.97	140	367.86	140 ¹⁾
14,01 - 14,20	06	8	22	6	6	5.0	443.65	xxxx ¹⁾	443.65	xxxx ²⁾	399.08	xxxx ¹⁾
14,21 - 15,99	08	8	22	6	8	12.5	443.65	xxxx ¹⁾	443.65	xxxx ²⁾	399.08	xxxx ¹⁾
16,00	08	8	22	6	8	12.5	407.97	160	407.97	160	367.86	160 ¹⁾
16,01 - 16,20	08	8	22	6	8	12.5	443.65	xxxx ¹⁾	443.65	xxxx ²⁾	399.08	xxxx ¹⁾
16,21 - 17,20	10	8	22	6	10	15.0	443.65	xxxx ¹⁾	443.65	xxxx ²⁾	399.08	xxxx ¹⁾
17,21 - 17,99	10	12	26	6	10	15.0	463.72	xxxx ¹⁾	463.72	xxxx ²⁾	416.91	xxxx ¹⁾
18,00	10	12	26	6	10	15.0	425.85	180	425.85	180	383.44	180 ¹⁾
18,01 - 19,99	10	12	26	6	10	15.0	463.72	xxxx ¹⁾	463.72	xxxx ²⁾	416.91	xxxx ¹⁾
20,00	10	12	26	6	10	15.0	425.85	200	425.85	200	383.44	200 ¹⁾
20,01 - 20,20	10	12	26	6	10	15.0	463.72	xxxx ¹⁾	463.72	xxxx ²⁾	416.91	xxxx ¹⁾
20,21 - 21,99	12	12	26	6	13	20.0	483.78	xxxx ¹⁾	483.78	xxxx ²⁾	434.73	xxxx ¹⁾
22,00	12	12	26	6	13	20.0	445.89	220	445.89	220	399.08	220 ¹⁾
22,01 - 23,99	12	12	26	6	13	20.0	483.78	xxxx ¹⁾	483.78	xxxx ²⁾	434.73	xxxx ¹⁾
24,00	12	12	26	6	13	20.0	445.89	240	445.89	240	399.08	240 ¹⁾
24,01 - 24,20	12	12	26	6	13	20.0	483.78	xxxx ¹⁾	483.78	xxxx ²⁾	434.73	xxxx ¹⁾
24,21 - 24,99	16	12	26	6	16	25.0	517.22	xxxx ¹⁾	517.22	xxxx ²⁾	465.96	xxxx ¹⁾
25,00	16	12	26	6	16	25.0	474.85	250	474.85	250	428.03	250 ¹⁾
25,01 - 25,99	16	12	26	6	16	25.0	517.22	xxxx ¹⁾	517.22	xxxx ²⁾	465.96	xxxx ¹⁾
26,00	16	12	26	6	16	25.0	474.85	260	474.85	260	428.03	260 ¹⁾
26,01 - 27,99	16	12	26	6	16	25.0	517.22	xxxx ¹⁾	517.22	xxxx ²⁾	465.96	xxxx ¹⁾
28,00	16	12	26	6	16	25.0	474.85	280	474.85	280	428.03	280 ¹⁾
28,01 - 28,20	16	12	26	6	16	25.0	517.22	xxxx ¹⁾	517.22	xxxx ²⁾	465.96	xxxx ¹⁾
28,21 - 29,20	16	12	26	6	16	25.0	572.95	xxxx ¹⁾	572.95	xxxx ²⁾	514.99	xxxx ¹⁾
29,21 - 29,99	16	12	26	8	16	25.0	572.95	xxxx ¹⁾	572.95	xxxx ²⁾	514.99	xxxx ¹⁾
30,00	16	12	26	8	16	25.0	526.15	300	526.15	300	474.85	300 ¹⁾
30,01 - 30,20	16	12	26	8	16	25.0	572.95	xxxx ¹⁾	572.95	xxxx ²⁾	514.99	xxxx ¹⁾

1) Not available ex stock, articles are non-returnable and cannot be exchanged / Delivery time 12 working days / Minimum order 2 pieces
 2) Not available ex stock, articles are non-returnable and cannot be exchanged / Delivery time 23 working days / Minimum order 2 pieces → v, Page 76

i For xxxx please indicate requested diameter in H7 in the order (e.g. 12.89 H7 → article no. 40 211 1289)!
 All other diameters and tolerance classes are also possible on request (e.g. 18.5^{+0.025} or 15 N7).

i Holders and accessories can be found in → **Catalogue – Clamping technology, Chapter 16.**

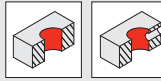
Monomax – Selection guide

Ø 5,60 – 25,89 mm									
Article no. (3xD)	40 635 ...	40 625 ...	40 656 ...	40 652 ...	40 648 ...	40 605 ...	40 657 ...	40 644 ...	40 640 ...
Article no. (5xD)	40 636 ...	40 626 ...	40 666 ...	40 653 ...	40 649 ...	40 606 ...	40 665 ...	40 645 ...	40 641 ...
KOMET no. (3xD)	56J.93	56J.93	56J.65	56J.65	56J.17	56J.71	56H.65	56H.65	56H.17
KOMET no. (5xD)	56R.93	56R.93	56R.65	56R.65	56R.17	56R.71	56Q.65	56Q.65	56Q.17
Cutting edge geometry	ASG4000	ASG3000	ASG3000	ASG0106	ASG0706	ASG3000	ASG3000	ASG0106	ASG0706
Lead angle	25°	45°	45°	45°	45°/8°	45°	45°	45°	45°/8°
Grade / coating	DST	DST	DBG-P	DBG-P	DBC	TIN	DBG-P	DBG-P	DBC
Preferred type available	✓	✓	✓	✓		✓			
Application	Through hole						Blind hole		
Material sub-group	Index								
		P	Non alloyed steel	P.1.1	●	●	●		○
		P.1.2	●	●	●		○	●	
		P.1.3	●	●	●		○	●	
		P.1.4	●	●	●		○	●	
		P.1.5	●	●	●		○	●	
	Low alloyed steel	P.2.1	●	●	●		○	●	
		P.2.2	●	●	●		○	●	
		P.2.3	●	●	●		○	●	
		P.2.4			●	●	○	●	
	High-alloy steel and high-alloy tool steel	P.3.1				●			●
		P.3.2				●			●
		P.3.3				●			●
	Stainless steel	P.4.1				●			●
		P.4.2				●			●
M	Stainless steel	M.1.1				●			●
		M.2.1				●			●
		M.3.1				●			●
K	Grey cast iron	K.1.1			●		○	●	
		K.1.2			●		○	●	
	Spherulitic graphite cast iron	K.2.1	○	●	●			●	
		K.2.2	○	●	●			●	
	Malleable iron	K.3.1	○	●	●			●	
		K.3.2	○	●	●			●	
N	Aluminum alloys	N.1.1				●			●
		N.1.2				●			●
	Cast aluminium alloys	N.2.1				●			●
		N.2.2				●			●
		N.2.3				●			●
	Copper and copper alloys (Bronze, Brass)	N.3.1		○			●		
		N.3.2		○			●		
		N.3.3					●		
	Magnesium alloys	N.4.1							
O	Non-metal materials	O.1.1							
		O.1.2							
		O.2.1							
		O.2.2							
		O.3.1				○			○

● = Main application
○ = Additional range of application

Monomax – High-speed reamers, short

- ▲ adjustable for smallest bore tolerances
- ▲ wear compensation within the tolerance zone
- ▲ retraction from the hole at 3–4 times the cutting feed rate
- ▲ up to tolerance class IT 5 with absolute process security, from the first hole

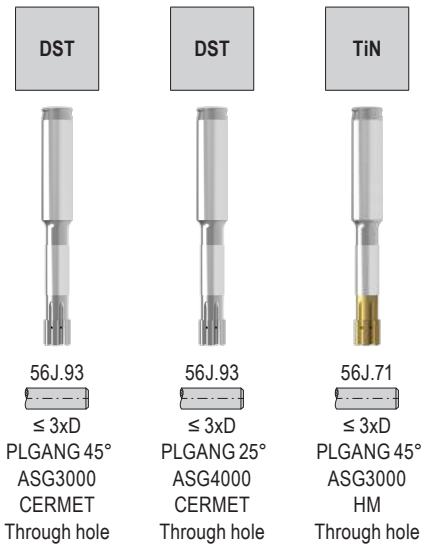
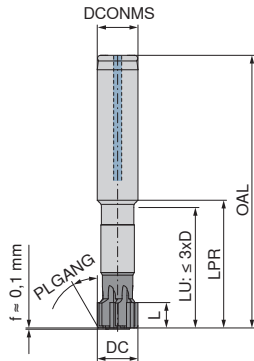

DC _{H7} mm	L mm	LU mm	LPR mm	OAL mm	DCONMS _{h6} mm	ZEFP	40 625 ...		40 635 ...		40 605 ...	
							£	U3/4E	£	U3/4E	£	U3/4E
5,60 - 5,99	9,5	35	40	85	12	4	804.53	xxxx ¹⁾	804.53	xxxx ¹⁾	804.53	xxxx ¹⁾
6,00	9,5	35	40	85	12	4	665.65	060	665.65	060	665.65	060
6,01 - 7,99	9,5	35	40	85	12	4	804.53	xxxx ¹⁾	804.53	xxxx ¹⁾	804.53	xxxx ¹⁾
8,00	9,5	35	40	85	12	4	690.72	080	690.72	080	690.72	080
8,01 - 8,89	9,5	35	40	85	12	4	804.53	xxxx ¹⁾	804.53	xxxx ¹⁾	804.53	xxxx ¹⁾
8,90 - 9,89	9,5	45	50	95	12	6	926.45	xxxx ¹⁾	926.45	xxxx ¹⁾	926.45	xxxx ¹⁾
9,90 - 9,99	9,5	45	50	95	12	6	926.45	xxxx ¹⁾	926.45	xxxx ¹⁾	926.45	xxxx ¹⁾
10,00	9,5	45	50	95	12	6	747.71	100	747.71	100	747.71	100
10,01 - 11,99	9,5	45	50	95	12	6	926.45	xxxx ¹⁾	926.45	xxxx ¹⁾	926.45	xxxx ¹⁾
12,00	9,5	45	50	95	12	6	770.51	120	770.51	120	770.51	120
12,01 - 13,99	9,5	45	50	95	12	6	926.45	xxxx ¹⁾	926.45	xxxx ¹⁾	926.45	xxxx ¹⁾
14,00	9,5	45	50	95	12	6	825.22	140	825.22	140	825.22	140
14,01 - 14,99	9,5	45	50	95	12	6	926.45	xxxx ¹⁾	926.45	xxxx ¹⁾	926.45	xxxx ¹⁾
15,00	9,5	45	50	95	12	6	845.73	150	845.73	150	845.73	150
15,01 - 15,89	9,5	45	50	95	12	6	926.45	xxxx ¹⁾	926.45	xxxx ¹⁾	926.45	xxxx ¹⁾
15,90 - 15,99	9,5	45	50	100	16	6	1,138.80	xxxx ¹⁾	1,138.80	xxxx ¹⁾	1,138.80	xxxx ¹⁾
16,00	9,5	45	50	100	16	6	866.25	160	866.25	160	866.25	160
16,01 - 17,99	9,5	45	50	100	16	6	1,138.80	xxxx ¹⁾	1,138.80	xxxx ¹⁾	1,138.80	xxxx ¹⁾
18,00	9,5	45	50	100	16	6	925.50	180	925.50	180	925.50	180
18,01 - 18,89	9,5	45	50	100	16	6	1,138.80	xxxx ¹⁾	1,138.80	xxxx ¹⁾	1,138.80	xxxx ¹⁾
18,90 - 19,99	9,5	55	60	120	20	6	1,382.41	xxxx ¹⁾	1,382.41	xxxx ¹⁾	1,382.41	xxxx ¹⁾
20,00	9,5	55	60	120	20	6	998.47	200	998.47	200	998.47	200
20,01 - 25,89	9,5	55	60	120	20	6	1,382.41	xxxx ¹⁾	1,382.41	xxxx ¹⁾	1,382.41	xxxx ¹⁾

1) Not available ex stock, articles are non-returnable and cannot be exchanged / Delivery time on request / Minimum order 2 pieces → v_c Page 77–80

i Do not heat shrink tools !

i For xxxx please indicate requested Ø in H7 in the order (e.g. 15.89 H7 → article no. 40 635 1589)!
All other diameters and tolerance classes are also possible on request (e.g. 18.5^{+0.025} or 18 N7).

i Detailed adjustment instructions are available to download in the online shop for the item.

i Further information on chamfer geometries (ASG) can be found on → page 100.

Monomax – High-speed reamers, short

- ▲ adjustable for smallest bore tolerances
- ▲ wear compensation within the tolerance zone
- ▲ retraction from the hole at 3–4 times the cutting feed rate
- ▲ up to tolerance class IT 5 with absolute process security, from the first hole

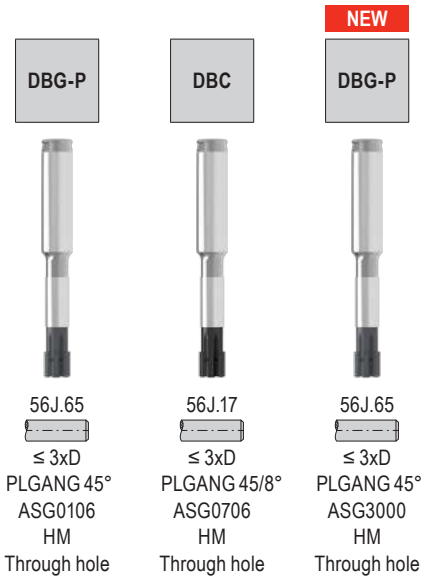
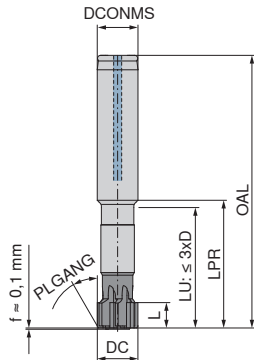

40 652 ...		40 648 ...		40 656 ...	
£		£		£	
U3/4E		U3/4E		U3/4E	
804.53	xxxx ¹⁾	804.53	xxxx ¹⁾	804.53	xxxx ¹⁾
363.80	06000	804.53	06000 ¹⁾	665.65	06000
804.53	xxxx ¹⁾	804.53	xxxx ¹⁾	804.53	xxxx ¹⁾
377.50	08000	804.53	08000 ¹⁾	690.72	08000
804.53	xxxx ¹⁾	804.53	xxxx ¹⁾	804.53	xxxx ¹⁾
926.45	xxxx ¹⁾	926.45	xxxx ¹⁾	926.45	xxxx ¹⁾
926.45	xxxx ¹⁾	926.45	xxxx ¹⁾	926.45	xxxx ¹⁾
408.66	10000	926.45	10000 ¹⁾	747.71	10000
926.45	xxxx ¹⁾	926.45	xxxx ¹⁾	926.45	xxxx ¹⁾
421.10	12000	926.45	12000 ¹⁾	770.51	12000
926.45	xxxx ¹⁾	926.45	xxxx ¹⁾	926.45	xxxx ¹⁾
451.03	14000	926.45	14000 ¹⁾	825.22	14000
926.45	xxxx ¹⁾	926.45	xxxx ¹⁾	926.45	xxxx ¹⁾
462.23	15000	926.45	15000 ¹⁾	845.73	15000
926.45	xxxx ¹⁾	926.45	xxxx ¹⁾	926.45	xxxx ¹⁾
1,138.80	xxxx ¹⁾	1,138.80	xxxx ¹⁾	1,138.80	xxxx ¹⁾
473.44	16000	1,138.80	16000 ¹⁾	866.25	16000
1,138.80	xxxx ¹⁾	1,138.80	xxxx ¹⁾	1,138.80	xxxx ¹⁾
505.84	18000	1,138.80	18000 ¹⁾	925.50	18000
1,138.80	xxxx ¹⁾	1,138.80	xxxx ¹⁾	1,138.80	xxxx ¹⁾
1,382.41	xxxx ¹⁾	1,382.41	xxxx ¹⁾	1,382.41	xxxx ¹⁾
545.72	20000	1,382.41	20000 ¹⁾	998.47	20000
1,382.41	xxxx ¹⁾	1,382.41	xxxx ¹⁾	1,382.41	xxxx ¹⁾

DC _{H7} mm	L mm	LU mm	LPR mm	OAL mm	DC ONMS _{h6} mm	ZEFP
5,60 - 5,99	9.5	35	40	85	12	4
6,00	9.5	35	40	85	12	4
6,01 - 7,99	9.5	35	40	85	12	4
8,00	9.5	35	40	85	12	4
8,01 - 8,89	9.5	35	40	85	12	4
8,90 - 9,89	9.5	45	50	95	12	6
9,90 - 9,99	9.5	45	50	95	12	6
10,00	9.5	45	50	95	12	6
10,01 - 11,99	9.5	45	50	95	12	6
12,00	9.5	45	50	95	12	6
12,01 - 13,99	9.5	45	50	95	12	6
14,00	9.5	45	50	95	12	6
14,01 - 14,99	9.5	45	50	95	12	6
15,00	9.5	45	50	95	12	6
15,01 - 15,89	9.5	45	50	95	12	6
15,90 - 15,99	9.5	45	50	100	16	6
16,00	9.5	45	50	100	16	6
16,01 - 17,99	9.5	45	50	100	16	6
18,00	9.5	45	50	100	16	6
18,01 - 18,89	9.5	45	50	100	16	6
18,90 - 19,99	9.5	55	60	120	20	6
20,00	9.5	55	60	120	20	6
20,01 - 25,89	9.5	55	60	120	20	6

P	●	●
M	●	
K		●
N		●
S		
H		
O		○

1) Not available ex stock, articles are non-returnable and cannot be exchanged / Delivery time on request / Minimum order 2 pieces

Do not heat shrink tools !

For xxxx please indicate requested Ø in H7 in the order (e.g. 15.89 H7 → article no. 40 652 1589)!
All other diameters and tolerance classes are also possible on request (e.g. 18.5^{+0.025} or 18 N7).

Detailed adjustment instructions are available to download in the online shop for the item.

Further information on chamfer geometries (ASG) can be found on → **page 100**.

Monomax – High-speed reamers, short

- ▲ adjustable for smallest bore tolerances
- ▲ wear compensation within the tolerance zone
- ▲ retraction from the hole at 3–4 times the cutting feed rate
- ▲ up to tolerance class IT 5 with absolute process security, from the first hole

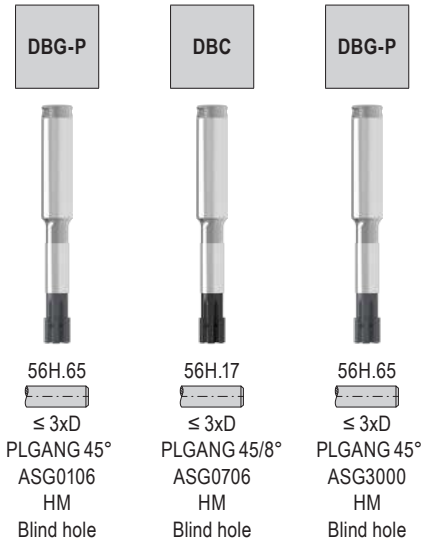
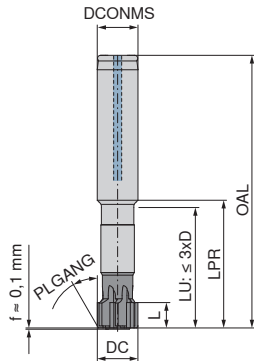

DC _{H7} mm	L mm	LU mm	LPR mm	OAL mm	DCONMS _{h6} mm	ZEFP
5,60 - 5,99	9,5	35	40	85	12	4
6,00	9,5	35	40	85	12	4
6,01 - 7,99	9,5	35	40	85	12	4
8,00	9,5	35	40	85	12	4
8,01 - 8,89	9,5	35	40	85	12	4
8,90 - 9,89	9,5	45	50	95	12	6
9,90 - 9,99	9,5	45	50	95	12	6
10,00	9,5	45	50	95	12	6
10,01 - 11,99	9,5	45	50	95	12	6
12,00	9,5	45	50	95	12	6
12,01 - 13,99	9,5	45	50	95	12	6
14,00	9,5	45	50	95	12	6
14,01 - 14,99	9,5	45	50	95	12	6
15,00	9,5	45	50	95	12	6
15,01 - 15,89	9,5	45	50	95	12	6
15,90 - 15,99	9,5	45	50	100	16	6
16,00	9,5	45	50	100	16	6
16,01 - 17,99	9,5	45	50	100	16	6
18,00	9,5	45	50	100	16	6
18,01 - 18,89	9,5	45	50	100	16	6
18,90 - 19,99	9,5	55	60	120	20	6
20,00	9,5	55	60	120	20	6
20,01 - 25,89	9,5	55	60	120	20	6

40 644 ...		40 640 ...		40 657 ...	
£		£		£	
U3/4E		U3/4E		U3/4E	
804.53	xxxx ¹⁾	804.53	xxxx ¹⁾	804.53	xxxx ¹⁾
804.53	06000 ¹⁾	804.53	06000 ¹⁾	804.53	06000 ¹⁾
804.53	xxxx ¹⁾	804.53	xxxx ¹⁾	804.53	xxxx ¹⁾
804.53	08000 ¹⁾	804.53	08000 ¹⁾	804.53	08000 ¹⁾
804.53	xxxx ¹⁾	804.53	xxxx ¹⁾	804.53	xxxx ¹⁾
926.45	xxxx ¹⁾	926.45	xxxx ¹⁾	926.45	xxxx ¹⁾
926.45	xxxx ¹⁾	926.45	xxxx ¹⁾	926.45	xxxx ¹⁾
926.45	10000 ¹⁾	926.45	10000 ¹⁾	926.45	10000 ¹⁾
926.45	xxxx ¹⁾	926.45	xxxx ¹⁾	926.45	xxxx ¹⁾
926.45	12000 ¹⁾	926.45	12000 ¹⁾	926.45	12000 ¹⁾
926.45	xxxx ¹⁾	926.45	xxxx ¹⁾	926.45	xxxx ¹⁾
926.45	14000 ¹⁾	926.45	14000 ¹⁾	926.45	14000 ¹⁾
926.45	xxxx ¹⁾	926.45	xxxx ¹⁾	926.45	xxxx ¹⁾
926.45	15000 ¹⁾	926.45	15000 ¹⁾	926.45	15000 ¹⁾
926.45	xxxx ¹⁾	926.45	xxxx ¹⁾	926.45	xxxx ¹⁾
1,138.80	xxxx ¹⁾	1,138.80	xxxx ¹⁾	1,138.80	xxxx ¹⁾
1,138.80	16000 ¹⁾	1,138.80	16000 ¹⁾	1,138.80	16000 ¹⁾
1,138.80	xxxx ¹⁾	1,138.80	xxxx ¹⁾	1,138.80	xxxx ¹⁾
1,138.80	18000 ¹⁾	1,138.80	18000 ¹⁾	1,138.80	18000 ¹⁾
1,138.80	xxxx ¹⁾	1,138.80	xxxx ¹⁾	1,138.80	xxxx ¹⁾
1,382.41	xxxx ¹⁾	1,382.41	xxxx ¹⁾	1,382.41	xxxx ¹⁾
1,382.41	20000 ¹⁾	1,382.41	20000 ¹⁾	1,382.41	20000 ¹⁾
1,382.41	xxxx ¹⁾	1,382.41	xxxx ¹⁾	1,382.41	xxxx ¹⁾

P	●	●
M	●	●
K	●	●
N	●	●
S	●	●
H	●	●
O	○	○

1) Not available ex stock, articles are non-returnable and cannot be exchanged / Delivery time on request / Minimum order 2 pieces → v_c Page 77–80

- Do not heat shrink tools !
- For xxxx please indicate requested Ø in H7 in the order (e.g. 15.89 H7 → article no. 40 644 1589)! All other diameters and tolerance classes are also possible on request (e.g. 18.5^{+0.025} or 18 N7).
- Detailed adjustment instructions are available to download in the online shop for the item.
- Further information on chamfer geometries (ASG) can be found on → page 100.

Monomax – High-speed reamers, long

- ▲ adjustable for the smallest bore tolerances
- ▲ wear compensation within the tolerance zone
- ▲ retraction from the hole at 3–4 times the cutting feed rate
- ▲ up to tolerance class IT 5 with absolute process security, from the first hole

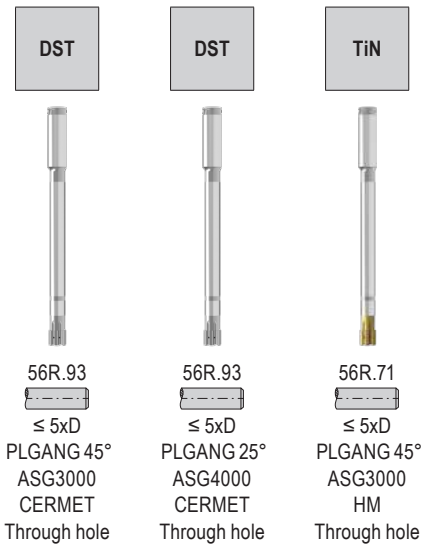
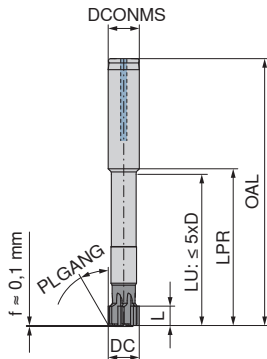

DC _{H7} mm	L mm	LU mm	LPR mm	OAL mm	DCONMS _{h6} mm	ZEFP
5,60 - 5,99	9,5	80	85	130	12	4
6,00	9,5	80	85	130	12	4
6,01 - 7,99	9,5	80	85	130	12	4
8,00	9,5	80	85	130	12	4
8,01 - 8,89	9,5	80	85	130	12	4
8,90 - 9,89	9,5	80	85	130	12	6
9,90 - 9,99	9,5	110	115	160	12	6
10,00	9,5	110	115	160	12	6
10,01 - 11,99	9,5	110	115	160	12	6
12,00	9,5	110	115	160	12	6
12,01 - 13,99	9,5	110	115	160	12	6
14,00	9,5	110	115	160	12	6
14,01 - 14,99	9,5	110	115	160	12	6
15,00	9,5	110	115	160	12	6
15,01 - 15,89	9,5	110	115	160	12	6
15,90 - 15,99	9,5	125	130	180	16	6
16,00	9,5	125	130	180	16	6
16,01 - 17,99	9,5	125	130	180	16	6
18,00	9,5	125	130	180	16	6
18,01 - 18,89	9,5	125	130	180	16	6
18,90 - 19,99	9,5	135	140	200	20	6
20,00	9,5	135	140	200	20	6
20,01 - 25,89	9,5	135	140	200	20	6

40 626 ...		40 636 ...		40 606 ...	
£		£		£	
U3/4E		U3/4E		U3/4E	
804.53	xxxx ¹⁾	804.53	xxxx ¹⁾	804.53	xxxx ¹⁾
665.65	060	665.65	060	665.65	060
804.53	xxxx ¹⁾	804.53	xxxx ¹⁾	804.53	xxxx ¹⁾
690.72	080	690.72	080	690.72	080
804.53	xxxx ¹⁾	804.53	xxxx ¹⁾	804.53	xxxx ¹⁾
926.45	xxxx ¹⁾	926.45	xxxx ¹⁾	926.45	xxxx ¹⁾
1,028.43	xxxx ¹⁾	1,028.43	xxxx ¹⁾	1,028.43	xxxx ¹⁾
747.71	100	747.71	100	747.71	100
1,028.43	xxxx ¹⁾	1,028.43	xxxx ¹⁾	1,028.43	xxxx ¹⁾
770.51	120	770.51	120	770.51	120
1,028.43	xxxx ¹⁾	1,028.43	xxxx ¹⁾	1,028.43	xxxx ¹⁾
825.22	140	825.22	140	825.22	140
1,028.43	xxxx ¹⁾	1,028.43	xxxx ¹⁾	1,028.43	xxxx ¹⁾
845.73	150	845.73	150	845.73	150
1,028.43	xxxx ¹⁾	1,028.43	xxxx ¹⁾	1,028.43	xxxx ¹⁾
1,138.80	xxxx ¹⁾	1,138.80	xxxx ¹⁾	1,138.80	xxxx ¹⁾
866.25	160	866.25	160	866.25	160
1,138.80	xxxx ¹⁾	1,138.80	xxxx ¹⁾	1,138.80	xxxx ¹⁾
925.50	180	925.50	180	925.50	180
1,138.80	xxxx ¹⁾	1,138.80	xxxx ¹⁾	1,138.80	xxxx ¹⁾
1,382.41	xxxx ¹⁾	1,382.41	xxxx ¹⁾	1,382.41	xxxx ¹⁾
998.47	200	998.47	200	998.47	200
1,382.41	xxxx ¹⁾	1,382.41	xxxx ¹⁾	1,382.41	xxxx ¹⁾

P	●	●	○
M			
K	●	○	○
N	○		●
S			
H			
O			

1) Not available ex stock, articles are non-returnable and cannot be exchanged / Delivery time on request / Minimum order 2 pieces

Do not heat shrink tools !

For xxxx please indicate requested Ø in H7 in the order (e.g. 15.89 H7 → article no. 40 636 1589)!
All other diameters and tolerance classes are also possible on request (e.g. 18.5^{+0.025} or 18 N7).

Detailed adjustment instructions are available to download in the online shop for the item.

Further information on chamfer geometries (ASG) can be found on → page 100.

Monomax – High-speed reamers, long

- ▲ adjustable for the smallest bore tolerances
- ▲ wear compensation within the tolerance zone
- ▲ retraction from the hole at 3–4 times the cutting feed rate
- ▲ up to tolerance class IT 5 with absolute process security, from the first hole

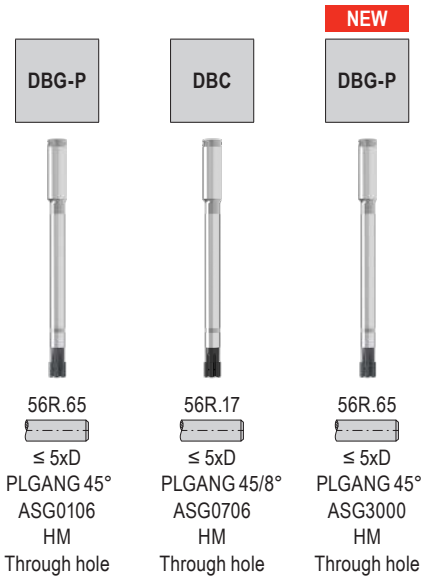
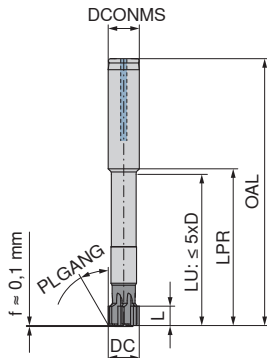

DC _{H7} mm	L mm	LU mm	LPR mm	OAL mm	DCONMS _{h6} mm	ZEFP
5,60 - 5,99	9,5	80	85	130	12	4
6,00	9,5	80	85	130	12	4
6,01 - 7,99	9,5	80	85	130	12	4
8,00	9,5	80	85	130	12	4
8,01 - 8,89	9,5	80	85	130	12	4
8,90 - 9,89	9,5	80	85	130	12	6
9,90 - 9,99	9,5	110	115	160	12	6
10,00	9,5	110	115	160	12	6
10,01 - 11,99	9,5	110	115	160	12	6
12,00	9,5	110	115	160	12	6
12,01 - 13,99	9,5	110	115	160	12	6
14,00	9,5	110	115	160	12	6
14,01 - 14,99	9,5	110	115	160	12	6
15,00	9,5	110	115	160	12	6
15,01 - 15,89	9,5	110	115	160	12	6
15,90 - 15,99	9,5	125	130	180	16	6
16,00	9,5	125	130	180	16	6
16,01 - 17,99	9,5	125	130	180	16	6
18,00	9,5	125	130	180	16	6
18,01 - 18,89	9,5	125	130	180	16	6
18,90 - 19,99	9,5	135	140	200	20	6
20,00	9,5	135	140	200	20	6
20,01 - 25,89	9,5	135	140	200	20	6

40 653 ...		40 649 ...		40 666 ...	
£		£		£	
U3/4E		U3/4E		U3/4E	
804.53	xxxx ¹⁾	804.53	xxxx ¹⁾	804.53	xxxx ¹⁾
363.80	06000	804.53	06000 ¹⁾	665.65	06000
804.53	xxxx ¹⁾	804.53	xxxx ¹⁾	804.53	xxxx ¹⁾
377.50	08000	804.53	08000 ¹⁾	690.72	08000
804.53	xxxx ¹⁾	804.53	xxxx ¹⁾	804.53	xxxx ¹⁾
926.45	xxxx ¹⁾	926.45	xxxx ¹⁾	926.45	xxxx ¹⁾
1,028.43	xxxx ¹⁾	1,028.43	xxxx ¹⁾	1,028.43	xxxx ¹⁾
408.66	10000	1,028.43	10000 ¹⁾	747.71	10000
1,028.43	xxxx ¹⁾	1,028.43	xxxx ¹⁾	1,028.43	xxxx ¹⁾
421.10	12000	1,028.43	12000 ¹⁾	770.51	12000
1,028.43	xxxx ¹⁾	1,028.43	xxxx ¹⁾	1,028.43	xxxx ¹⁾
451.03	14000	1,028.43	14000 ¹⁾	825.22	14000
1,028.43	xxxx ¹⁾	1,028.43	xxxx ¹⁾	1,028.43	xxxx ¹⁾
462.23	15000	1,028.43	15000 ¹⁾	845.73	15000
1,028.43	xxxx ¹⁾	1,028.43	xxxx ¹⁾	1,028.43	xxxx ¹⁾
1,138.80	xxxx ¹⁾	1,138.80	xxxx ¹⁾	1,138.80	xxxx ¹⁾
473.44	16000	1,138.80	16000 ¹⁾	866.25	16000
1,138.80	xxxx ¹⁾	1,138.80	xxxx ¹⁾	1,138.80	xxxx ¹⁾
505.84	18000	1,138.80	18000 ¹⁾	925.50	18000
1,138.80	xxxx ¹⁾	1,138.80	xxxx ¹⁾	1,138.80	xxxx ¹⁾
1,382.41	xxxx ¹⁾	1,382.41	xxxx ¹⁾	1,382.41	xxxx ¹⁾
545.72	20000	1,382.41	20000 ¹⁾	998.47	20000
1,382.41	xxxx ¹⁾	1,382.41	xxxx ¹⁾	1,382.41	xxxx ¹⁾

P	●	●
M	●	
K		●
N		●
S		
H		
O		○

1) Not available ex stock, articles are non-returnable and cannot be exchanged / Delivery time on request / Minimum order 2 pieces

Do not heat shrink tools !

For xxxx please indicate requested Ø in H7 in the order (e.g. 15.89 H7 → article no. 40 653 1589)!
All other diameters and tolerance classes are also possible on request (e.g. 18.5^{+0.025} or 18 N7).

Detailed adjustment instructions are available to download in the online shop for the item.

Further information on chamfer geometries (ASG) can be found on → **page 100**.

Monomax – High-speed reamers, long

- ▲ adjustable for the smallest bore tolerances
- ▲ wear compensation within the tolerance zone
- ▲ retraction from the hole at 3–4 times the cutting feed rate
- ▲ up to tolerance class IT 5 with absolute process security, from the first hole

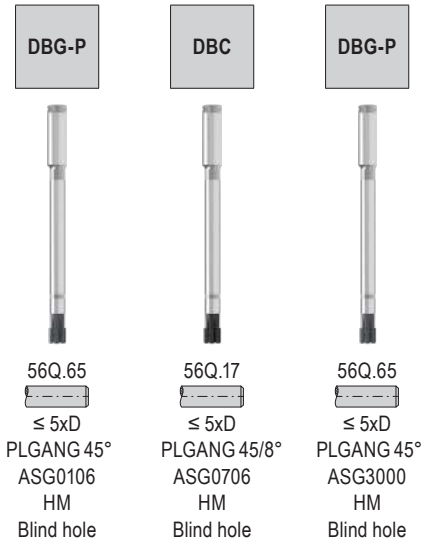
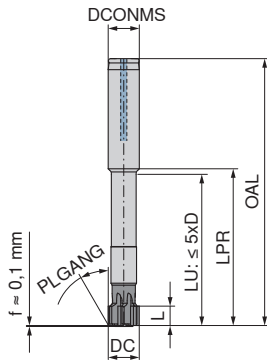

DC _{H7} mm	L mm	LU mm	LPR mm	OAL mm	DCONMS _{h6} mm	ZEFP
5,60 - 5,99	9,5	80	85	130	12	4
6,00	9,5	80	85	130	12	4
6,01 - 7,99	9,5	80	85	130	12	4
8,00	9,5	80	85	130	12	4
8,01 - 8,89	9,5	80	85	130	12	4
8,90 - 9,89	9,5	80	85	130	12	6
9,90 - 9,99	9,5	110	115	160	12	6
10,00	9,5	110	115	160	12	6
10,01 - 11,99	9,5	110	115	160	12	6
12,00	9,5	110	115	160	12	6
12,01 - 13,99	9,5	110	115	160	12	6
14,00	9,5	110	115	160	12	6
14,01 - 14,99	9,5	110	115	160	12	6
15,00	9,5	110	115	160	12	6
15,01 - 15,89	9,5	110	115	160	12	6
15,90 - 15,99	9,5	125	130	180	16	6
16,00	9,5	125	130	180	16	6
16,01 - 17,99	9,5	125	130	180	16	6
18,00	9,5	125	130	180	16	6
18,01 - 18,89	9,5	125	130	180	16	6
18,90 - 19,99	9,5	135	140	200	20	6
20,00	9,5	135	140	200	20	6
20,01 - 25,89	9,5	135	140	200	20	6

40 645 ...		40 641 ...		40 665 ...	
£		£		£	
804.53	xxxx ¹⁾	804.53	xxxx ¹⁾	804.53	xxxx ¹⁾
804.53	06000 ¹⁾	804.53	06000 ¹⁾	804.53	06000 ¹⁾
804.53	xxxx ¹⁾	804.53	xxxx ¹⁾	804.53	xxxx ¹⁾
804.53	08000 ¹⁾	804.53	08000 ¹⁾	804.53	08000 ¹⁾
804.53	xxxx ¹⁾	804.53	xxxx ¹⁾	804.53	xxxx ¹⁾
926.45	xxxx ¹⁾	926.45	xxxx ¹⁾	926.45	xxxx ¹⁾
1,028.43	xxxx ¹⁾	1,028.43	xxxx ¹⁾	1,028.43	xxxx ¹⁾
1,028.43	10000 ¹⁾	1,028.43	10000 ¹⁾	1,028.43	10000 ¹⁾
1,028.43	xxxx ¹⁾	1,028.43	xxxx ¹⁾	1,028.43	xxxx ¹⁾
1,028.43	12000 ¹⁾	1,028.43	12000 ¹⁾	1,028.43	12000 ¹⁾
1,028.43	xxxx ¹⁾	1,028.43	xxxx ¹⁾	1,028.43	xxxx ¹⁾
1,028.43	14000 ¹⁾	1,028.43	14000 ¹⁾	1,028.43	14000 ¹⁾
1,028.43	xxxx ¹⁾	1,028.43	xxxx ¹⁾	1,028.43	xxxx ¹⁾
1,028.43	15000 ¹⁾	1,028.43	15000 ¹⁾	1,028.43	15000 ¹⁾
1,028.43	xxxx ¹⁾	1,028.43	xxxx ¹⁾	1,028.43	xxxx ¹⁾
1,138.80	xxxx ¹⁾	1,138.80	xxxx ¹⁾	1,138.80	xxxx ¹⁾
1,138.80	16000 ¹⁾	1,138.80	16000 ¹⁾	1,138.80	16000 ¹⁾
1,138.80	xxxx ¹⁾	1,138.80	xxxx ¹⁾	1,138.80	xxxx ¹⁾
1,138.80	18000 ¹⁾	1,138.80	18000 ¹⁾	1,138.80	18000 ¹⁾
1,138.80	xxxx ¹⁾	1,138.80	xxxx ¹⁾	1,138.80	xxxx ¹⁾
1,382.41	xxxx ¹⁾	1,382.41	xxxx ¹⁾	1,382.41	xxxx ¹⁾
1,382.41	20000 ¹⁾	1,382.41	20000 ¹⁾	1,382.41	20000 ¹⁾
1,382.41	xxxx ¹⁾	1,382.41	xxxx ¹⁾	1,382.41	xxxx ¹⁾

P	•	•
M	•	
K		•
N		•
S		
H		
O		○

1) Not available ex stock, articles are non-returnable and cannot be exchanged / Delivery time on request / Minimum order 2 pieces

Do not heat shrink tools !

For xxxx please indicate requested Ø in H7 in the order (e.g. 15.89 H7 → article no. 40 645 1589)!
All other diameters and tolerance classes are also possible on request (e.g. 18.5^{+0.025} or 18 N7).

Detailed adjustment instructions are available to download in the online shop for the item.

Further information on chamfer geometries (ASG) can be found on → page 100.

Fullmax – High-performance machine reamers, short

- ▲ extremely irregular pitch
- ▲ designed for high-speed machining
- ▲ specialised geometry and coating for universal use

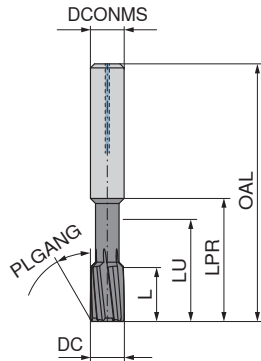

51P.57

Left Hand Helix
PLGANG 30°
ASG2210
Solid carbide
Through hole

40 483 ...

£	
U4/4R	
122.84	04000
124.67	05000
127.44	06000
133.00	07000
133.00	08000
187.94	09000
187.94	10000
249.36	11000
249.36	12000
369.76	16000

DC _{H7} mm	L mm	LU mm	LPR mm	OAL mm	DCONMS _{h6} mm	ZEFP
4	12	24	28	50	4	4
5	12	31	36	64	6	4
6	12	31	36	64	6	4
7	16	31	36	70	8	6
8	16	31	36	70	8	6
9	16	35	40	80	10	6
10	16	35	40	80	10	6
11	20	40	45	90	12	6
12	20	40	45	90	12	6
16	20	40	45	93	16	8

P	●
M	●
K	●
N	○
S	○
H	○
O	○

→ v_c Page 83

Further information on chamfer geometries (ASG) can be found on → page 100.

Fullmax – High-performance machine reamers, short

- ▲ extremely irregular pitch
- ▲ designed for high-speed machining
- ▲ specialised geometry and coating for universal use

- ▲ tolerance: $\varnothing 2,96 - 6,03 \text{ mm} = +0,004 \text{ mm}$
- ▲ tolerance: $\varnothing 6,04 - 20,05 \text{ mm} = +0,005 \text{ mm}$

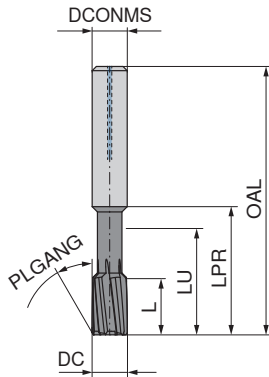

51P.57
Left Hand Helix
PLGANG 30°
ASG2210
Solid carbide
Through hole

40 489 ...

DC +0,004/+0,005 mm	L mm	LU mm	LPR mm	OAL mm	DCONMS _{h6} mm	ZEFP	£	
2,96 - 3,96	12	24	28	50	4	4	153.54	xxxxx ¹⁾
3,97	12	24	28	50	4	4	130.22	03970
3,98	12	24	28	50	4	4	130.22	03980
3,99	12	24	28	50	4	4	130.22	03990
4,00	12	24	28	50	4	4	130.22	04000
4,01	12	24	28	50	4	4	130.22	04010
4,02	12	24	28	50	4	4	130.22	04020
4,03	12	24	28	50	4	4	130.22	04030
4,04 - 4,05	12	24	28	50	4	4	153.54	xxxxx ¹⁾
4,06 - 4,96	12	31	36	64	6	4	155.85	xxxxx ¹⁾
4,97	12	31	36	64	6	4	133.00	04970
4,98	12	31	36	64	6	4	133.00	04980
4,99	12	31	36	64	6	4	133.00	04990
5,00	12	31	36	64	6	4	133.00	05000
5,01	12	31	36	64	6	4	133.00	05010
5,02	12	31	36	64	6	4	133.00	05020
5,03	12	31	36	64	6	4	133.00	05030
5,04 - 5,96	12	31	36	64	6	4	155.85	xxxxx ¹⁾
5,97	12	31	36	64	6	4	134.03	05970
5,98	12	31	36	64	6	4	134.03	05980
5,99	12	31	36	64	6	4	134.03	05990
6,00	12	31	36	64	6	4	134.03	06000
6,01	12	31	36	64	6	4	134.03	06010
6,02	12	31	36	64	6	4	134.03	06020
6,03	12	31	36	64	6	4	134.03	06030
6,04 - 6,05	12	31	36	64	6	4	158.17	xxxxx ¹⁾
6,06 - 7,96	16	31	36	70	8	6	164.04	xxxxx ¹⁾
7,97	16	31	36	70	8	6	140.50	07970
7,98	16	31	36	70	8	6	140.50	07980
7,99	16	31	36	70	8	6	140.50	07990
8,00	16	31	36	70	8	6	140.50	08000
8,01	16	31	36	70	8	6	140.50	08010
8,02	16	31	36	70	8	6	140.50	08020
8,03	16	31	36	70	8	6	140.50	08030
8,04 - 8,05	16	31	36	70	8	6	164.04	xxxxx ¹⁾

P	●
M	●
K	●
N	○
S	○
H	○
O	○

1) Not available ex stock, articles are non-returnable and cannot be exchanged / Delivery time on request

This tool concept permits numerous tolerances. For sizes covered please refer to the table on → **page 101**.
For xxxxx please indicate required \varnothing in the order (e.g. $\varnothing 8.82 \text{ mm}$ → Article No. 40 489 08820)!

Further information on chamfer geometries (ASG) can be found on → **page 100**.

Fullmax – High-performance machine reamers, short

- ▲ extremely irregular pitch
- ▲ designed for high-speed machining
- ▲ specialised geometry and coating for universal use

- ▲ tolerance: $\varnothing 2,96 - 6,03 \text{ mm} = +0,004 \text{ mm}$
- ▲ tolerance: $\varnothing 6,04 - 20,05 \text{ mm} = +0,005 \text{ mm}$

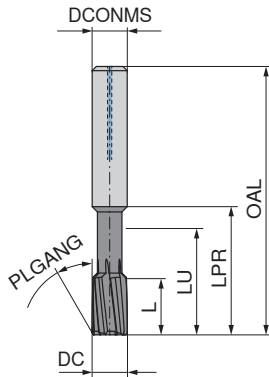

51P.57

Left Hand Helix
PLGANG 30°
ASG2210
Solid carbide
Through hole

40 489 ...

£	
U4/4R	
203.64	xxxxx ¹⁾
200.07	09970
200.07	09980
200.07	09990
200.07	10000
200.07	10010
200.07	10020
200.07	10030
203.64	xxxxx ¹⁾
307.08	xxxxx ¹⁾
266.10	11970
266.10	11980
266.10	11990
266.10	12000
266.10	12010
266.10	12020
266.10	12030
307.08	xxxxx ¹⁾
358.21	xxxxx ¹⁾
408.32	xxxxx ¹⁾
461.06	xxxxx ¹⁾
491.09	xxxxx ¹⁾
521.45	xxxxx ¹⁾

DC $+0,004/+0,005$ mm	L mm	LU mm	LPR mm	OAL mm	DCONMS _{h6} mm	ZEFP
8,06 - 9,96	16	35	40	80	10	6
9,97	16	35	40	80	10	6
9,98	16	35	40	80	10	6
9,99	16	35	40	80	10	6
10,00	16	35	40	80	10	6
10,01	16	35	40	80	10	6
10,02	16	35	40	80	10	6
10,03	16	35	40	80	10	6
10,04 - 10,05	16	35	40	80	10	6
10,06 - 11,96	20	40	45	90	12	6
11,97	20	40	45	90	12	6
11,98	20	40	45	90	12	6
11,99	20	40	45	90	12	6
12,00	20	40	45	90	12	6
12,01	20	40	45	90	12	6
12,02	20	40	45	90	12	6
12,03	20	40	45	90	12	6
12,04 - 12,05	20	40	45	90	12	6
12,06 - 14,05	20	40	45	90	14	6
14,06 - 15,96	20	40	45	93	16	6
15,97 - 16,05	20	40	45	93	16	8
16,06 - 18,05	20	47	52	100	18	8
18,06 - 20,05	20	45	50	102	20	8

P	●
M	●
K	●
N	○
S	○
H	○
O	○

1) Not available ex stock, articles are non-returnable and cannot be exchanged / Delivery time on request

→ v. Page 83



This tool concept permits numerous tolerances. For sizes covered please refer to the table on → **page 101**.
For xxxxx please indicate required \varnothing in the order (e.g. $\varnothing 8.82 \text{ mm}$ → Article No. 40 489 08820)!



Further information on chamfer geometries (ASG) can be found on → **page 100**.

Fullmax – High-performance machine reamers, short

- ▲ extremely irregular pitch
- ▲ designed for high-speed machining
- ▲ specialised geometry and coating for universal use

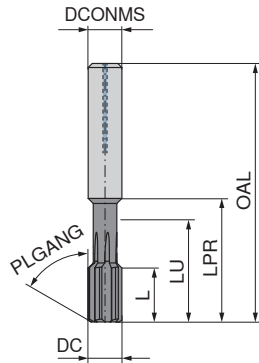

51M.57

straight flute
PLGANG 60°
ASG2110
Solid carbide
Blind hole

40 481 ...

£	
U4/4R	
102.33	04000
104.22	05000
108.89	06000
114.43	07000
114.43	08000
163.70	09000
163.70	10000
217.71	11000
217.71	12000
330.97	16000

DC _{H7} mm	L mm	LU mm	LPR mm	OAL mm	DCONMS _{h6} mm	ZEFP
4	12	24	28	50	4	4
5	12	31	36	64	6	4
6	12	31	36	64	6	4
7	16	31	36	70	8	6
8	16	31	36	70	8	6
9	16	35	40	80	10	6
10	16	35	40	80	10	6
11	20	40	45	90	12	6
12	20	40	45	90	12	6
16	20	40	45	93	16	8

P	●
M	●
K	●
N	○
S	○
H	○
O	○

→ v_c Page 83

Further information on chamfer geometries (ASG) can be found on → page 100.

Fullmax – High-performance machine reamers, short

- ▲ extremely irregular pitch
- ▲ designed for high-speed machining
- ▲ specialised geometry and coating for universal use

- ▲ tolerance: $\varnothing 2,96 - 6,03 \text{ mm} = +0,004 \text{ mm}$
- ▲ tolerance: $\varnothing 6,04 - 20,05 \text{ mm} = +0,005 \text{ mm}$

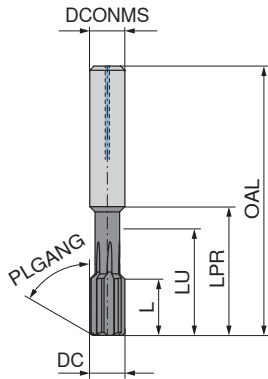

51M.57
straight flute
PLGANG 60°
ASG2110
Solid carbide
Blind hole

40 488 ...

DC +0,004/+0,005 mm	L mm	LU mm	LPR mm	OAL mm	DCONMS _{h6} mm	ZEFP	£	
2,96 - 3,96	12	24	28	50	4	4	127.92	xxxxx ¹⁾
3,97	12	24	28	50	4	4	109.78	03970
3,98	12	24	28	50	4	4	109.78	03980
3,99	12	24	28	50	4	4	109.78	03990
4,00	12	24	28	50	4	4	109.78	04000
4,01	12	24	28	50	4	4	109.78	04010
4,02	12	24	28	50	4	4	109.78	04020
4,03	12	24	28	50	4	4	109.78	04030
4,04 - 4,05	12	24	28	50	4	4	127.92	xxxxx ¹⁾
4,06 - 4,96	12	31	36	64	6	4	131.50	xxxxx ¹⁾
4,97	12	31	36	64	6	4	112.55	04970
4,98	12	31	36	64	6	4	112.55	04980
4,99	12	31	36	64	6	4	112.55	04990
5,00	12	31	36	64	6	4	112.55	05000
5,01	12	31	36	64	6	4	112.55	05010
5,02	12	31	36	64	6	4	112.55	05020
5,03	12	31	36	64	6	4	112.55	05030
5,04 - 5,96	12	31	36	64	6	4	131.50	xxxxx ¹⁾
5,97	12	31	36	64	6	4	114.43	05970
5,98	12	31	36	64	6	4	114.43	05980
5,99	12	31	36	64	6	4	114.43	05990
6,00	12	31	36	64	6	4	114.43	06000
6,01	12	31	36	64	6	4	114.43	06010
6,02	12	31	36	64	6	4	114.43	06020
6,03	12	31	36	64	6	4	114.43	06030
6,04 - 6,05	12	31	36	64	6	4	132.63	xxxxx ¹⁾
6,06 - 7,96	16	31	36	70	8	6	141.89	xxxxx ¹⁾
7,97	16	31	36	70	8	6	120.07	07970
7,98	16	31	36	70	8	6	120.07	07980
7,99	16	31	36	70	8	6	120.07	07990
8,00	16	31	36	70	8	6	120.07	08000
8,01	16	31	36	70	8	6	120.07	08010
8,02	16	31	36	70	8	6	120.07	08020
8,03	16	31	36	70	8	6	120.07	08030
8,04 - 8,05	16	31	36	70	8	6	141.89	xxxxx ¹⁾

P	●
M	●
K	●
N	○
S	○
H	○
O	○

1) Not available ex stock, articles are non-returnable and cannot be exchanged / Delivery time on request

This tool concept permits numerous tolerances. For sizes covered please refer to the table on → **page 101**.
For xxxxx please indicate required \varnothing in the order (e.g. $\varnothing 8.82 \text{ mm}$ → Article No. 40 488 08820)!

Further information on chamfer geometries (ASG) can be found on → **page 100**.

Fullmax – High-performance machine reamers, short

- ▲ extremely irregular pitch
- ▲ designed for high-speed machining
- ▲ specialised geometry and coating for universal use

- ▲ tolerance: $\varnothing 2,96 - 6,03 \text{ mm} = +0,004 \text{ mm}$
- ▲ tolerance: $\varnothing 6,04 - 20,05 \text{ mm} = +0,005 \text{ mm}$

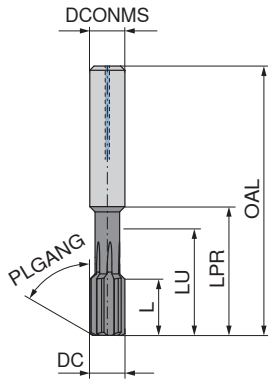

51M.57
straight flute
PLGANG 60°
ASG2110
Solid carbide
Blind hole

40 488 ...

£	
U4/4R	
180.32	xxxxx ¹⁾
174.90	09970
174.90	09980
174.90	09990
174.90	10000
174.90	10010
174.90	10020
174.90	10030
180.32	xxxxx ¹⁾
273.36	xxxxx ¹⁾
233.56	11970
233.56	11980
233.56	11990
233.56	12000
233.56	12010
233.56	12020
233.56	12030
273.36	xxxxx ¹⁾
317.57	xxxxx ¹⁾
367.57	xxxxx ¹⁾
414.90	xxxxx ¹⁾
440.07	xxxxx ¹⁾
476.76	xxxxx ¹⁾

DC ^{+0,004/+0,005} mm	L mm	LU mm	LPR mm	OAL mm	DCONMS _{h6} mm	ZEFP
8,06 - 9,96	16	35	40	80	10	6
9,97	16	35	40	80	10	6
9,98	16	35	40	80	10	6
9,99	16	35	40	80	10	6
10,00	16	35	40	80	10	6
10,01	16	35	40	80	10	6
10,02	16	35	40	80	10	6
10,03	16	35	40	80	10	6
10,04 - 10,05	16	35	40	80	10	6
10,06 - 11,96	20	40	45	90	12	6
11,97	20	40	45	90	12	6
11,98	20	40	45	90	12	6
11,99	20	40	45	90	12	6
12,00	20	40	45	90	12	6
12,01	20	40	45	90	12	6
12,02	20	40	45	90	12	6
12,03	20	40	45	90	12	6
12,04 - 12,05	20	40	45	90	12	6
12,06 - 14,05	20	40	45	90	14	6
14,06 - 15,96	20	40	45	93	16	6
15,97 - 16,05	20	40	45	93	16	8
16,06 - 18,05	20	47	52	100	18	8
18,06 - 20,05	20	45	50	102	20	8

P	●
M	●
K	●
N	○
S	○
H	○
O	○

1) Not available ex stock, articles are non-returnable and cannot be exchanged / Delivery time on request

→ v. Page 83

This tool concept permits numerous tolerances. For sizes covered please refer to the table on → **page 101**.
For xxxxx please indicate required \varnothing in the order (e.g. $\varnothing 8.82 \text{ mm}$ → Article No. 40 488 08820)!

Further information on chamfer geometries (ASG) can be found on → **page 100**.

Fullmax – High-performance machine reamers, long

- ▲ extremely irregular pitch
- ▲ designed for high-speed machining
- ▲ specialised geometries and coatings

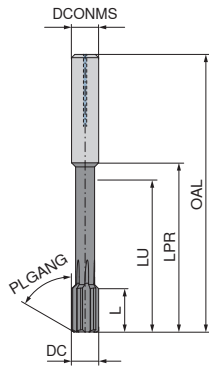

UNI	VA	ALU
DBG-U	DBQ	DBC-N
52P.57	52S.44	52N.17
Left Hand Helix PLGANG 30° ASG2210 Solid carbide Through hole	Left Hand Helix PLGANG 30° ASG2231 Solid carbide Through hole	straight flute PLGANG 30° ASG2270 Solid carbide Through hole

DC _{H7} mm	L mm	LU mm	LPR mm	OAL mm	DCONMS _{h6} mm	ZEFP
4	12	28	32	60	4	4
5	12	35	40	76	6	4
6	12	35	40	76	6	4
7	16	60	65	101	8	6
8	16	60	65	101	8	6
9	16	63	68	108	10	6
10	16	63	68	108	10	6
11	20	80	85	130	12	6
12	20	80	85	130	12	6
16	20	97	102	150	16	6

40 484 ...		40 401 ...		40 471 ...	
£		£		£	
U4/4R		U4/4R		U4/4R	
164.46	04000	180.65	04000	180.65	04000 ¹⁾
166.94	05000	183.14	05000	183.14	05000 ¹⁾
170.70	06000	186.89	06000	186.89	06000 ¹⁾
178.17	07000	195.61	07000	195.61	07000 ¹⁾
178.17	08000	195.61	08000	195.61	08000 ¹⁾
251.68	09000	277.84	09000	277.84	09000 ¹⁾
251.68	10000	277.84	10000	277.84	10000 ¹⁾
333.89	11000	366.28	11000	366.28	11000 ¹⁾
333.89	12000	366.28	12000	366.28	12000 ¹⁾
438.55	16000	482.14	16000	482.14	16000 ¹⁾

P	●	●
M	●	●
K	●	●
N	○	●
S	○	○
H	○	○
O	○	○

1) Not available ex stock, articles are non-returnable and cannot be exchanged / Delivery time on request / Minimum order 2 pieces

Further information on chamfer geometries (ASG) can be found on → **page 100.**

Fullmax – High-performance machine reamers, long

- ▲ extremely irregular pitch
- ▲ designed for high-speed machining
- ▲ specialised geometries and coatings

- ▲ tolerance: Ø 2,96 – 5,96 mm = +0,004 mm
- ▲ tolerance: Ø 5,97 – 20,05 mm = +0,005 mm

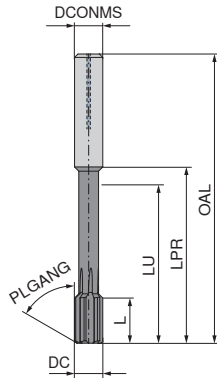

UNI	VA	K	ALU	H
DBG-U	DBQ	DBG-P	DBC-N	DBF-A
52P.57 Left Hand Helix PLGANG 30° ASG2210 Solid carbide Through hole	52S.44 Left Hand Helix PLGANG 30° ASG2231 Solid carbide Through hole	52J.65 straight flute PLGANG 30° ASG2350 Solid carbide Through hole	52N.17 straight flute PLGANG 30° ASG2270 Solid carbide Through hole	52G.55 straight flute PLGANG 30° ASG2360 Solid carbide Through hole

DC +0,004/+0,005 mm	L mm	LU mm	LPR mm	OAL mm	DCONMS _{h6} mm	ZEPF	40 486 ...		40 403 ...		40 477 ...		40 473 ...		40 475 ...	
							£		£		£		£		£	
2,96 - 3,96	12	28	32	60	4	4	373.93	xxxxx ²⁾	382.54	xxxxx ¹⁾	382.54	xxxxx ¹⁾	382.54	xxxxx ¹⁾	382.54	xxxxx ¹⁾
2,96 - 3,96	12	28	32	60	4	6										
3,97	12	28	32	60	4	4	174.43	03970	191.88	03970 ¹⁾	382.54	03970 ¹⁾	382.54	03970 ¹⁾	382.54	03970 ¹⁾
3,97	12	28	32	60	4	6										
3,98	12	28	32	60	4	4	174.43	03980	191.88	03980 ¹⁾	382.54	03980 ¹⁾	382.54	03980 ¹⁾	382.54	03980 ¹⁾
3,98	12	28	32	60	4	6										
3,99	12	28	32	60	4	4	174.43	03990	191.88	03990 ¹⁾	382.54	03990 ¹⁾	382.54	03990 ¹⁾	382.54	03990 ¹⁾
3,99	12	28	32	60	4	6										
4,00	12	28	32	60	4	4	174.43	04000	191.88	04000 ¹⁾	382.54	04000 ¹⁾	382.54	04000 ¹⁾	436.27	04000 ¹⁾
4,00	12	28	32	60	4	6										
4,01	12	28	32	60	4	4	174.43	04010	191.88	04010 ¹⁾	382.54	04010 ¹⁾	382.54	04010 ¹⁾	382.54	04010 ¹⁾
4,01	12	28	32	60	4	6										
4,02	12	28	32	60	4	4	174.43	04020	191.88	04020 ¹⁾	382.54	04020 ¹⁾	382.54	04020 ¹⁾	382.54	04020 ¹⁾
4,02	12	28	32	60	4	6										
4,03	12	28	32	60	4	4	174.43	04030	191.88	04030 ¹⁾	382.54	04030 ¹⁾	382.54	04030 ¹⁾	382.54	04040 ¹⁾
4,03	12	28	32	60	4	6										
4,04 - 4,05	12	28	32	60	4	4	373.93	xxxxx ²⁾	382.54	xxxxx ¹⁾	382.54	xxxxx ¹⁾	382.54	xxxxx ¹⁾	382.54	xxxxx ¹⁾
4,04 - 4,05	12	28	32	60	4	6										
4,06 - 4,96	12	35	40	76	6	4	379.60	xxxxx ²⁾	396.61	xxxxx ¹⁾	396.61	xxxxx ¹⁾	396.61	xxxxx ¹⁾	396.61	xxxxx ¹⁾
4,06 - 4,96	12	35	40	76	6	6										
4,97	12	35	40	76	6	4	178.17	04970	195.61	04970 ¹⁾	396.61	04970 ¹⁾	396.61	04970 ¹⁾	396.61	04970 ¹⁾
4,97	12	35	40	76	6	6										
4,98	12	35	40	76	6	4	178.17	04980	195.61	04980 ¹⁾	396.61	04980 ¹⁾	396.61	04980 ¹⁾	396.61	04980 ¹⁾
4,98	12	35	40	76	6	6										
4,99	12	35	40	76	6	4	178.17	04990	195.61	04990 ¹⁾	396.61	04990 ¹⁾	396.61	04990 ¹⁾	396.61	04990 ¹⁾
4,99	12	35	40	76	6	6										
5,00	12	35	40	76	6	4	178.17	05000	195.61	05000 ¹⁾	396.61	05000 ¹⁾	396.61	05000 ¹⁾	450.54	05000 ¹⁾
5,00	12	35	40	76	6	6										
5,01	12	35	40	76	6	4	178.17	05010	195.61	05010 ¹⁾	396.61	05010 ¹⁾	396.61	05010 ¹⁾	396.61	05010 ¹⁾
5,01	12	35	40	76	6	6										
5,02	12	35	40	76	6	4	178.17	05020	195.61	05020 ¹⁾	396.61	05020 ¹⁾	396.61	05020 ¹⁾	396.61	05020 ¹⁾
5,02	12	35	40	76	6	6										

P	●	●				
M	●	●				
K	●		●			
N	○			●		
S	○					
H	○					●
O						○

- 1) Not available ex stock, articles are non-returnable and cannot be exchanged / Delivery time on request / Minimum order 2 pieces → v_c Page 81+82
- 2) Not available ex stock, articles are non-returnable and cannot be exchanged / Delivery time on request

This tool concept permits numerous tolerances. For sizes covered please refer to the table on → page 101. For xxxxx please indicate required Ø in the order (e.g. Ø 8.82 mm → Article No. 40 486 08820)!

Further information on chamfer geometries (ASG) can be found on → page 100.

Fullmax – High-performance machine reamers, long

- ▲ extremely irregular pitch
- ▲ designed for high-speed machining
- ▲ specialised geometries and coatings

- ▲ tolerance: Ø 2,96 – 5,96 mm = +0,004 mm
- ▲ tolerance: Ø 5,97 – 20,05 mm = +0,005 mm

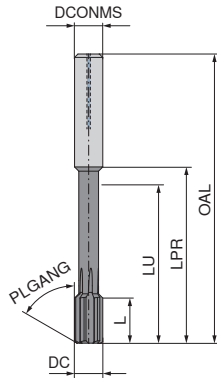

UNI	VA	K	ALU	H
DBG-U	DBQ	DBG-P	DBC-N	DBF-A
52P.57 Left Hand Helix PLGANG 30° ASG2210 Solid carbide Through hole	52S.44 Left Hand Helix PLGANG 30° ASG2231 Solid carbide Through hole	52J.65 straight flute PLGANG 30° ASG2350 Solid carbide Through hole	52N.17 straight flute PLGANG 30° ASG2270 Solid carbide Through hole	52G.55 straight flute PLGANG 30° ASG2360 Solid carbide Through hole

DC +0,004/+0,005 mm	L mm	LU mm	LPR mm	OAL mm	DCONMS _{h6} mm	ZEPF	40 486 ...		40 403 ...		40 477 ...		40 473 ...		40 475 ...	
							£	U4/4R	£	U4/4R	£	U4/4R	£	U4/4R	£	U4/4R
5,03	12	35	40	76	6	4	178.17	05030	195.61	05030 ¹⁾	396.61	05030 ¹⁾	396.61	05030 ¹⁾	396.61	05030 ¹⁾
5,03	12	35	40	76	6	6					396.61	05030 ¹⁾				
5,04 - 5,96	12	35	40	76	6	4	379.60	xxxxx ²⁾	396.61	xxxxx ¹⁾	396.61	xxxxx ¹⁾	396.61	xxxxx ¹⁾	396.61	xxxxx ¹⁾
5,04 - 5,96	12	35	40	76	6	6					396.61	xxxxx ¹⁾				
5,97	12	35	40	76	6	4	179.40	05970	198.10	05970 ¹⁾	396.61	05970 ¹⁾	396.61	05970 ¹⁾	396.61	05970 ¹⁾
5,97	12	35	40	76	6	6					396.61	05970 ¹⁾				
5,98	12	35	40	76	6	4	179.40	05980	198.10	05980 ¹⁾	396.61	05980 ¹⁾	396.61	05980 ¹⁾	396.61	05980 ¹⁾
5,98	12	35	40	76	6	6					396.61	05980 ¹⁾				
5,99	12	35	40	76	6	4	179.40	05990	198.10	05990 ¹⁾	396.61	05990 ¹⁾	396.61	05990 ¹⁾	396.61	05990 ¹⁾
5,99	12	35	40	76	6	6					396.61	05990 ¹⁾				
6,00	12	35	40	76	6	4	179.40	06000	198.10	06000 ¹⁾	450.54	06000 ¹⁾	396.61	06000 ¹⁾	450.54	06000 ¹⁾
6,00	12	35	40	76	6	6					450.54	06000 ¹⁾				
6,01	12	35	40	76	6	4	179.40	06010	198.10	06010 ¹⁾	396.61	06010 ¹⁾	396.61	06010 ¹⁾	396.61	06010 ¹⁾
6,01	12	35	40	76	6	6					396.61	06010 ¹⁾				
6,02	12	35	40	76	6	4	179.40	06020	198.10	06020 ¹⁾	396.61	06020 ¹⁾	396.61	06020 ¹⁾	396.61	06020 ¹⁾
6,02	12	35	40	76	6	6					396.61	06020 ¹⁾				
6,03	12	35	40	76	6	4	179.40	06030	198.10	06030 ¹⁾	396.61	06030 ¹⁾	396.61	06030 ¹⁾	396.61	06030 ¹⁾
6,03	12	35	40	76	6	6					396.61	06030 ¹⁾				
6,04 - 6,05	12	35	40	76	6	4	385.27	xxxxx ²⁾	396.61	xxxxx ¹⁾	396.61	xxxxx ¹⁾	396.61	xxxxx ¹⁾	396.61	xxxxx ¹⁾
6,04 - 6,05	12	35	40	76	6	6					396.61	xxxxx ¹⁾				
6,06 - 7,96	16	60	65	101	8	6	399.55	xxxxx ²⁾	407.93	xxxxx ¹⁾	407.93	xxxxx ¹⁾	407.93	xxxxx ¹⁾	407.93	xxxxx ¹⁾
6,06 - 7,96	16	60	65	101	8	8					407.93	xxxxx ¹⁾				
7,97	16	60	65	101	8	6	188.13	07970	206.82	07970 ¹⁾	407.93	07970 ¹⁾	407.93	07970 ¹⁾	407.93	07970 ¹⁾
7,97	16	60	65	101	8	8					407.93	07970 ¹⁾				
7,98	16	60	65	101	8	6	188.13	07980	206.82	07980 ¹⁾	407.93	07980 ¹⁾	407.93	07980 ¹⁾	407.93	07980 ¹⁾
7,98	16	60	65	101	8	8					407.93	07980 ¹⁾				
7,99	16	60	65	101	8	6	188.13	07990	206.82	07990 ¹⁾	407.93	07990 ¹⁾	407.93	07990 ¹⁾	407.93	07990 ¹⁾
7,99	16	60	65	101	8	8					407.93	07990 ¹⁾				
8,00	16	60	65	101	8	6	188.13	08000	206.82	08000 ¹⁾	464.59	08000 ¹⁾	407.93	08000 ¹⁾	464.59	08000 ¹⁾
8,00	16	60	65	101	8	8					464.59	08000 ¹⁾				
8,01	16	60	65	101	8	6	188.13	08010	206.82	08010 ¹⁾	407.93	08010 ¹⁾	407.93	08010 ¹⁾	407.93	08010 ¹⁾
8,01	16	60	65	101	8	8					407.93	08010 ¹⁾				

P	●	●				
M	●	●				
K	●		●			
N	○			●		
S	○					
H	○					●
O						○

1) Not available ex stock, articles are non-returnable and cannot be exchanged / Delivery time on request / Minimum order 2 pieces → v_c Page 81+82
 2) Not available ex stock, articles are non-returnable and cannot be exchanged / Delivery time on request

This tool concept permits numerous tolerances. For sizes covered please refer to the table on → page 101.
 For xxxxx please indicate required Ø in the order (e.g. Ø 8.82 mm → Article No. 40 486 08820)!

Further information on chamfer geometries (ASG) can be found on → page 100.

Fullmax – High-performance machine reamers, long

- ▲ extremely irregular pitch
- ▲ designed for high-speed machining
- ▲ specialised geometries and coatings

- ▲ tolerance: Ø 2,96 – 5,96 mm = +0,004 mm
- ▲ tolerance: Ø 5,97 – 20,05 mm = +0,005 mm

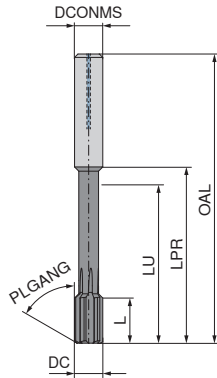

UNI	VA	K	ALU	H
DBG-U	DBQ	DBG-P	DBC-N	DBF-A
52P.57 Left Hand Helix PLGANG 30° ASG2210 Solid carbide Through hole	52S.44 Left Hand Helix PLGANG 30° ASG2231 Solid carbide Through hole	52J.65 straight flute PLGANG 30° ASG2350 Solid carbide Through hole	52N.17 straight flute PLGANG 30° ASG2270 Solid carbide Through hole	52G.55 straight flute PLGANG 30° ASG2360 Solid carbide Through hole

DC +0,004/+0,005 mm	L mm	LU mm	LPR mm	OAL mm	DCONMS _{h6} mm	ZEPF	40 486 ...		40 403 ...		40 477 ...		40 473 ...		40 475 ...	
							£		£		£		£		£	
8,02	16	60	65	101	8	6	188.13	08020	206.82	08020 ¹⁾	407.93	08020 ¹⁾	407.93	08020 ¹⁾	407.93	08020 ¹⁾
8,02	16	60	65	101	8	8										
8,03	16	60	65	101	8	6	188.13	08030	206.82	08030 ¹⁾	407.93	08030 ¹⁾	407.93	08030 ¹⁾	407.93	08030 ¹⁾
8,03	16	60	65	101	8	8										
8,04 - 8,05	16	60	65	101	8	6	399.55	xxxxx ²⁾	407.93	xxxxx ¹⁾	407.93	xxxxx ¹⁾	407.93	xxxxx ¹⁾	407.93	xxxxx ¹⁾
8,04 - 8,05	16	60	65	101	8	8										
8,06 - 9,96	16	63	68	108	10	6	495.85	xxxxx ²⁾	575.19	xxxxx ¹⁾	575.19	xxxxx ¹⁾	575.19	xxxxx ¹⁾	575.19	xxxxx ¹⁾
8,06 - 9,96	16	63	68	108	10	8										
9,97	16	63	68	108	10	6	267.87	09970	295.29	09970 ¹⁾	575.19	09970 ¹⁾	575.19	09970 ¹⁾	575.19	09970 ¹⁾
9,97	16	63	68	108	10	8										
9,98	16	63	68	108	10	6	267.87	09980	295.29	09980 ¹⁾	575.19	09980 ¹⁾	575.19	09980 ¹⁾	575.19	09980 ¹⁾
9,98	16	63	68	108	10	8										
9,99	16	63	68	108	10	6	267.87	09990	295.29	09990 ¹⁾	575.19	09990 ¹⁾	575.19	09990 ¹⁾	575.19	09990 ¹⁾
9,99	16	63	68	108	10	8										
10,00	16	63	68	108	10	6	267.87	10000	295.29	10000 ¹⁾	654.50	10000 ¹⁾	575.19	10000 ¹⁾	654.50	10000 ¹⁾
10,00	16	63	68	108	10	8										
10,01	16	63	68	108	10	6	267.87	10010	295.29	10010 ¹⁾	575.19	10010 ¹⁾	575.19	10010 ¹⁾	575.19	10010 ¹⁾
10,01	16	63	68	108	10	8										
10,02	16	63	68	108	10	6	267.87	10020	295.29	10020 ¹⁾	575.19	10020 ¹⁾	575.19	10020 ¹⁾	575.19	10020 ¹⁾
10,02	16	63	68	108	10	8										
10,03	16	63	68	108	10	6	267.87	10030	295.29	10030 ¹⁾	575.19	10030 ¹⁾	575.19	10030 ¹⁾	575.19	10030 ¹⁾
10,03	16	63	68	108	10	8										
10,04 - 10,05	16	63	68	108	10	6	495.85	xxxxx ²⁾	575.19	xxxxx ¹⁾	575.19	xxxxx ¹⁾	575.19	xxxxx ¹⁾	575.19	xxxxx ¹⁾
10,04 - 10,05	16	63	68	108	10	8										
10,06 - 11,96	20	80	85	130	12	6	747.88	xxxxx ²⁾	770.53	xxxxx ¹⁾	770.53	xxxxx ¹⁾	770.53	xxxxx ¹⁾	770.53	xxxxx ¹⁾
10,06 - 11,96	20	80	85	130	12	8										
11,97	20	80	85	130	12	6	356.32	11970	392.46	11970 ¹⁾	770.53	11970 ¹⁾	770.53	11970 ¹⁾	770.53	11970 ¹⁾
11,97	20	80	85	130	12	8										
11,98	20	80	85	130	12	6	356.32	11980	392.46	11980 ¹⁾	770.53	11980 ¹⁾	770.53	11980 ¹⁾	770.53	11980 ¹⁾
11,98	20	80	85	130	12	8										
11,99	20	80	85	130	12	6	356.32	11990	392.46	11990 ¹⁾	770.53	11990 ¹⁾	770.53	11990 ¹⁾	770.53	11990 ¹⁾
11,99	20	80	85	130	12	8										

P	●	●				
M	●	●				
K	●		●			
N	○			●		
S	○					
H	○					●
O						○

1) Not available ex stock, articles are non-returnable and cannot be exchanged / Delivery time on request / Minimum order 2 pieces → v_c Page 81+82
 2) Not available ex stock, articles are non-returnable and cannot be exchanged / Delivery time on request

This tool concept permits numerous tolerances. For sizes covered please refer to the table on → page 101.
 For xxxxx please indicate required Ø in the order (e.g. Ø 8.82 mm → Article No. 40 486 08820)!

Further information on chamfer geometries (ASG) can be found on → page 100.

Fullmax – High-performance machine reamers, long

- ▲ extremely irregular pitch
- ▲ designed for high-speed machining
- ▲ specialised geometries and coatings

- ▲ tolerance: Ø 2,96 – 5,96 mm = +0,004 mm
- ▲ tolerance: Ø 5,97 – 20,05 mm = +0,005 mm

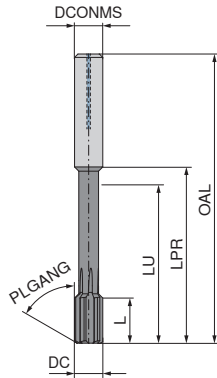

UNI	VA	K	ALU	H
DBG-U	DBQ	DBG-P	DBC-N	DBF-A
52P.57 Left Hand Helix PLGANG 30° ASG2210 Solid carbide Through hole	52S.44 Left Hand Helix PLGANG 30° ASG2231 Solid carbide Through hole	52J.65 straight flute PLGANG 30° ASG2350 Solid carbide Through hole	52N.17 straight flute PLGANG 30° ASG2270 Solid carbide Through hole	52G.55 straight flute PLGANG 30° ASG2360 Solid carbide Through hole

DC +0,004/+0,005 mm	L mm	LU mm	LPR mm	OAL mm	DCONMS _{h6} mm	ZEFP	40 486 ...		40 403 ...		40 477 ...		40 473 ...		40 475 ...	
							£		£		£		£		£	
12,00	20	80	85	130	12	6	356.32	12000	392.46	12000 ¹⁾	875.45	12000 ¹⁾	770.53	12000 ¹⁾	875.45	12000 ¹⁾
12,01	20	80	85	130	12	6	356.32	12010	392.46	12010 ¹⁾	770.53	12010 ¹⁾	770.53	12010 ¹⁾	770.53	12010 ¹⁾
12,02	20	80	85	130	12	6	356.32	12020	392.46	12020 ¹⁾	770.53	12020 ¹⁾	770.53	12020 ¹⁾	770.53	12020 ¹⁾
12,03	20	80	85	130	12	6	356.32	12030	392.46	12030 ¹⁾	770.53	12030 ¹⁾	770.53	12030 ¹⁾	770.53	12030 ¹⁾
12,04 - 12,05	20	80	85	130	12	8	747.88	xxxxx ²⁾	770.53	xxxxx ¹⁾	770.53	xxxxx ¹⁾	770.53	xxxxx ¹⁾	770.53	xxxxx ¹⁾
12,06 - 14,05	20	80	85	130	14	6	872.50	xxxxx ²⁾	898.12	xxxxx ¹⁾	898.12	xxxxx ¹⁾	898.12	xxxxx ¹⁾	898.12	xxxxx ¹⁾
14,06 - 16,05	20	97	102	150	16	6	994.45	xxxxx ²⁾	1,019.83	xxxxx ¹⁾	1,019.83	xxxxx ¹⁾	1,019.83	xxxxx ¹⁾	1,019.83	xxxxx ¹⁾
16,06 - 18,05	20	97	102	150	18	6	1,059.48	xxxxx ²⁾	1,107.76	xxxxx ¹⁾	1,107.76	xxxxx ¹⁾	1,107.76	xxxxx ¹⁾	1,107.76	xxxxx ¹⁾
18,06 - 20,05	20	105	110	160	20	6	1,124.76	xxxxx ²⁾	1,167.13	xxxxx ¹⁾	1,167.13	xxxxx ¹⁾	1,167.13	xxxxx ¹⁾	1,167.13	xxxxx ¹⁾

P	●	●				
M	●	●				
K	●		●			
N	○			●		
S	○					
H	○					●
O						○

1) Not available ex stock, articles are non-returnable and cannot be exchanged / Delivery time on request / Minimum order 2 pieces → v_c Page 81+82
 2) Not available ex stock, articles are non-returnable and cannot be exchanged / Delivery time on request

i This tool concept permits numerous tolerances. For sizes covered please refer to the table on → page 101.
 For xxxxx please indicate required Ø in the order (e.g. Ø 8.82 mm → Article No. 40 486 08820)!

i Further information on chamfer geometries (ASG) can be found on → page 100.

Fullmax – High-performance machine reamers, long

- ▲ extremely irregular pitch
- ▲ designed for high-speed machining
- ▲ specialised geometries and coatings

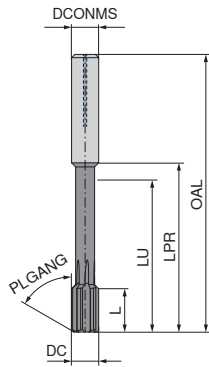

UNI	VA	ALU
DBG-U	DBQ	DBC-N
52M.57 straight flute PLGANG 60° ASG2110 Solid carbide Blind hole	52T.45 straight flute PLGANG 45° ASG2131 Solid carbide Blind hole	52Q.17 straight flute PLGANG 60° ASG2170 Solid carbide Blind hole

DC _{H7} mm	L mm	LU mm	LPR mm	OAL mm	DCONMS _{h6} mm	ZEFP
4	12	28	32	60	4	4
5	12	35	40	76	6	4
6	12	35	40	76	6	4
7	16	60	65	101	8	6
8	16	60	65	101	8	6
9	16	63	68	108	10	6
10	16	63	68	108	10	6
11	20	80	85	130	12	6
12	20	80	85	130	12	6
16	20	97	102	150	16	6

40 485 ...		40 402 ...		40 472 ...	
£		£		£	
U4/4R		U4/4R		U4/4R	
137.05	04000	150.74	04000	150.74	04000 ¹⁾
139.53	05000	154.49	05000	154.49	05000 ¹⁾
145.78	06000	160.71	06000	160.71	06000 ¹⁾
153.24	07000	168.18	07000	168.18	07000 ¹⁾
153.24	08000	168.18	08000	168.18	08000 ¹⁾
219.28	09000	241.70	09000	241.70	09000 ¹⁾
219.28	10000	241.70	10000	241.70	10000 ¹⁾
291.53	11000	320.20	11000	320.20	11000 ¹⁾
291.53	12000	320.20	12000	320.20	12000 ¹⁾
392.46	16000	432.32	16000	432.32	16000 ¹⁾

P	●	●
M	●	●
K	●	●
N	○	●
S	○	○
H	○	○
O	○	○

1) Not available ex stock, articles are non-returnable and cannot be exchanged / Delivery time on request / Minimum order 2 pieces

Further information on chamfer geometries (ASG) can be found on → **page 100.**

Fullmax – High-performance machine reamers, long

- ▲ extremely irregular pitch
- ▲ designed for high-speed machining
- ▲ specialised geometries and coatings

- ▲ tolerance: Ø 2,96 – 5,96 mm = +0,004 mm
- ▲ tolerance: Ø 5,97 – 20,05 mm = +0,005 mm

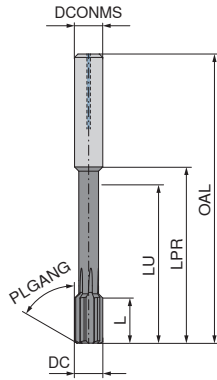

UNI	VA	K	ALU	H
DBG-U	DBQ	DBG-P	DBC-N	DBF-A
52M.57 straight flute PLGANG 60° ASG2110 Solid carbide Blind hole	52T.45 straight flute PLGANG 45° ASG2131 Solid carbide Blind hole	52K.65 straight flute PLGANG 30° ASG2350 Solid carbide Blind hole	52Q.17 straight flute PLGANG 60° ASG2170 Solid carbide Blind hole	52H.55 straight flute PLGANG 30° ASG2360 Solid carbide Blind hole

DC +0,004/+0,005 mm	L mm	LU mm	LPR mm	OAL mm	DCONMS _{h6} mm	ZEPF	40 487 ...		40 404 ...		40 478 ...		40 474 ...		40 476 ...	
							£	U4/4R	£	U4/4R	£	U4/4R	£	U4/4R	£	U4/4R
2,96 - 3,96	12	28	32	60	4	4	311.61	xxxxx ²⁾	322.94	xxxxx ¹⁾	322.94	xxxxx ¹⁾	322.94	xxxxx ¹⁾	322.94	xxxxx ¹⁾
2,96 - 3,96	12	28	32	60	4	6										
3,97	12	28	32	60	4	4	147.01	03970	161.98	03970 ¹⁾	322.94	03970 ¹⁾	322.94	03970 ¹⁾	322.94	03970 ¹⁾
3,97	12	28	32	60	4	6										
3,98	12	28	32	60	4	4	147.01	03980	161.98	03980 ¹⁾	322.94	03980 ¹⁾	322.94	03980 ¹⁾	322.94	03980 ¹⁾
3,98	12	28	32	60	4	6										
3,99	12	28	32	60	4	4	147.01	03990	161.98	03990 ¹⁾	322.94	03990 ¹⁾	322.94	03990 ¹⁾	322.94	03990 ¹⁾
3,99	12	28	32	60	4	6										
4,00	12	28	32	60	4	4	147.01	04000	161.98	04000 ¹⁾	322.94	04000 ¹⁾	322.94	04000 ¹⁾	322.94	04000 ¹⁾
4,00	12	28	32	60	4	6										
4,01	12	28	32	60	4	4	147.01	04010	161.98	04010 ¹⁾	322.94	04010 ¹⁾	322.94	04010 ¹⁾	322.94	04010 ¹⁾
4,01	12	28	32	60	4	6										
4,02	12	28	32	60	4	4	147.01	04020	161.98	04020 ¹⁾	322.94	04020 ¹⁾	322.94	04020 ¹⁾	322.94	04020 ¹⁾
4,02	12	28	32	60	4	6										
4,03	12	28	32	60	4	4	147.01	04030	161.98	04030 ¹⁾	322.94	04030 ¹⁾	322.94	04030 ¹⁾	322.94	04030 ¹⁾
4,03	12	28	32	60	4	6										
4,04 - 4,05	12	28	32	60	4	4	311.61	xxxxx ²⁾	322.94	xxxxx ¹⁾	322.94	xxxxx ¹⁾	322.94	xxxxx ¹⁾	322.94	xxxxx ¹⁾
4,04 - 4,05	12	28	32	60	4	6										
4,06 - 4,96	12	35	40	76	6	4	320.22	xxxxx ²⁾	331.57	xxxxx ¹⁾	331.57	xxxxx ¹⁾	331.57	xxxxx ¹⁾	331.57	xxxxx ¹⁾
4,06 - 4,96	12	35	40	76	6	6										
4,97	12	35	40	76	6	4	150.74	04970	164.46	04970 ¹⁾	331.57	04970 ¹⁾	331.57	04970 ¹⁾	331.57	04970 ¹⁾
4,97	12	35	40	76	6	6										
4,98	12	35	40	76	6	4	150.74	04980	164.46	04980 ¹⁾	331.57	04980 ¹⁾	331.57	04980 ¹⁾	331.57	04980 ¹⁾
4,98	12	35	40	76	6	6										
4,99	12	35	40	76	6	4	150.74	04990	164.46	04990 ¹⁾	331.57	04990 ¹⁾	331.57	04990 ¹⁾	331.57	04990 ¹⁾
4,99	12	35	40	76	6	6										
5,00	12	35	40	76	6	4	150.74	05000	164.46	05000 ¹⁾	331.57	05000 ¹⁾	331.57	05000 ¹⁾	331.57	05000 ¹⁾
5,00	12	35	40	76	6	6										
5,01	12	35	40	76	6	4	150.74	05010	164.46	05010 ¹⁾	331.57	05010 ¹⁾	331.57	05010 ¹⁾	331.57	05010 ¹⁾
5,01	12	35	40	76	6	6										
5,02	12	35	40	76	6	4	150.74	05020	164.46	05020 ¹⁾	331.57	05020 ¹⁾	331.57	05020 ¹⁾	331.57	05020 ¹⁾
5,02	12	35	40	76	6	6										

P	●	●														
M	●	●														
K	●															
N	○															
S	○															
H	○															
O																

1) Not available ex stock, articles are non-returnable and cannot be exchanged / Delivery time on request / Minimum order 2 pieces → v_c Page 81+82
 2) Not available ex stock, articles are non-returnable and cannot be exchanged / Delivery time on request

This tool concept permits numerous tolerances. For sizes covered please refer to the table on → page 101.
 For xxxxx please indicate required Ø in the order (e.g. Ø 8.82 mm → Article No. 40 487 08820)!

Further information on chamfer geometries (ASG) can be found on → page 100.

Fullmax – High-performance machine reamers, long

- ▲ extremely irregular pitch
- ▲ designed for high-speed machining
- ▲ specialised geometries and coatings

- ▲ tolerance: Ø 2,96 – 5,96 mm = +0,004 mm
- ▲ tolerance: Ø 5,97 – 20,05 mm = +0,005 mm

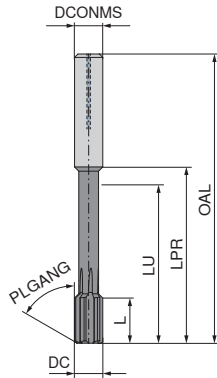

UNI	VA	K	ALU	H
DBG-U	DBQ	DBG-P	DBC-N	DBF-A
52M.57 straight flute PLGANG 60° ASG2110 Solid carbide Blind hole	52T.45 straight flute PLGANG 45° ASG2131 Solid carbide Blind hole	52K.65 straight flute PLGANG 30° ASG2350 Solid carbide Blind hole	52Q.17 straight flute PLGANG 60° ASG2170 Solid carbide Blind hole	52H.55 straight flute PLGANG 30° ASG2360 Solid carbide Blind hole

DC +0,004/+0,005 mm	L mm	LU mm	LPR mm	OAL mm	DCONMS _{h6} mm	ZEPF	40 487 ...		40 404 ...		40 478 ...		40 474 ...		40 476 ...	
							£	05030	£	05030 ¹⁾	£	05030 ¹⁾	£	05030 ¹⁾	£	05030 ¹⁾
5,03	12	35	40	76	6	4	150.74	05030	164.46	05030 ¹⁾	331.57	05030 ¹⁾	331.57	05030 ¹⁾	331.57	05030 ¹⁾
5,04 - 5,96	12	35	40	76	6	4	320.22	xxxxx ²⁾	331.57	xxxxx ¹⁾	331.57	xxxxx ¹⁾	331.57	xxxxx ¹⁾	331.57	xxxxx ¹⁾
5,04 - 5,96	12	35	40	76	6	6										
5,97	12	35	40	76	6	4	153.24	05970	168.18	05970 ¹⁾	331.57	05970 ¹⁾	331.57	05970 ¹⁾	331.57	05970 ¹⁾
5,97	12	35	40	76	6	6										
5,98	12	35	40	76	6	4	153.24	05980	168.18	05980 ¹⁾	331.57	05980 ¹⁾	331.57	05980 ¹⁾	331.57	05980 ¹⁾
5,98	12	35	40	76	6	6										
5,99	12	35	40	76	6	4	153.24	05990	168.18	05990 ¹⁾	331.57	05990 ¹⁾	331.57	05990 ¹⁾	331.57	05990 ¹⁾
5,99	12	35	40	76	6	6										
6,00	12	35	40	76	6	4	153.24	06000	168.18	06000 ¹⁾	331.57	06000 ¹⁾	331.57	06000 ¹⁾	331.57	06000 ¹⁾
6,00	12	35	40	76	6	6										
6,01	12	35	40	76	6	4	153.24	06010	168.18	06010 ¹⁾	331.57	06010 ¹⁾	331.57	06010 ¹⁾	331.57	06010 ¹⁾
6,01	12	35	40	76	6	6										
6,02	12	35	40	76	6	4	153.24	06020	168.18	06020 ¹⁾	331.57	06020 ¹⁾	331.57	06020 ¹⁾	331.57	06020 ¹⁾
6,02	12	35	40	76	6	6										
6,03	12	35	40	76	6	4	153.24	06030	168.18	06030 ¹⁾	331.57	06030 ¹⁾	331.57	06030 ¹⁾	331.57	06030 ¹⁾
6,03	12	35	40	76	6	6										
6,04 - 6,05	12	35	40	76	6	4	322.94	xxxxx ²⁾	331.57	xxxxx ¹⁾	331.57	xxxxx ¹⁾	331.57	xxxxx ¹⁾	331.57	xxxxx ¹⁾
6,04 - 6,05	12	35	40	76	6	6										
6,06 - 7,96	16	60	65	101	8	6	345.61	xxxxx ²⁾	356.93	xxxxx ¹⁾	356.93	xxxxx ¹⁾	356.93	xxxxx ¹⁾	356.93	xxxxx ¹⁾
6,06 - 7,96	16	60	65	101	8	8										
7,97	16	60	65	101	8	6	160.71	07970	176.92	07970 ¹⁾	356.93	07970 ¹⁾	356.93	07970 ¹⁾	356.93	07970 ¹⁾
7,97	16	60	65	101	8	8										
7,98	16	60	65	101	8	6	160.71	07980	176.92	07980 ¹⁾	356.93	07980 ¹⁾	356.93	07980 ¹⁾	356.93	07980 ¹⁾
7,98	16	60	65	101	8	8										
7,99	16	60	65	101	8	6	160.71	07990	176.92	07990 ¹⁾	356.93	07990 ¹⁾	356.93	07990 ¹⁾	356.93	07990 ¹⁾
7,99	16	60	65	101	8	8										
8,00	16	60	65	101	8	6	160.71	08000	176.92	08000 ¹⁾	356.93	08000 ¹⁾	356.93	08000 ¹⁾	356.93	08000 ¹⁾
8,00	16	60	65	101	8	8										
8,01	16	60	65	101	8	6	160.71	08010	176.92	08010 ¹⁾	356.93	08010 ¹⁾	356.93	08010 ¹⁾	356.93	08010 ¹⁾
8,01	16	60	65	101	8	8										

P	●	●				
M	●	●				
K	●		●			
N	○			●		
S	○					
H	○					●
O						○

1) Not available ex stock, articles are non-returnable and cannot be exchanged / Delivery time on request / Minimum order 2 pieces
2) Not available ex stock, articles are non-returnable and cannot be exchanged / Delivery time on request

→ v_c Page 81+82

This tool concept permits numerous tolerances. For sizes covered please refer to the table on → page 101.
For xxxxx please indicate required Ø in the order (e.g. Ø 8.82 mm → Article No. 40 487 08820)!

Further information on chamfer geometries (ASG) can be found on → page 100.

Fullmax – High-performance machine reamers, long

- ▲ extremely irregular pitch
- ▲ designed for high-speed machining
- ▲ specialised geometries and coatings

- ▲ tolerance: Ø 2,96 – 5,96 mm = +0,004 mm
- ▲ tolerance: Ø 5,97 – 20,05 mm = +0,005 mm

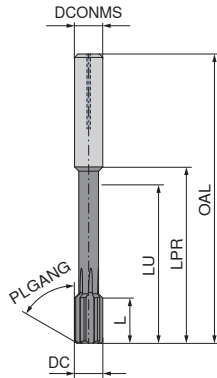

UNI	VA	K	ALU	H
DBG-U	DBQ	DBG-P	DBC-N	DBF-A
52M.57 straight flute PLGANG 60° ASG2110 Solid carbide Blind hole	52T.45 straight flute PLGANG 45° ASG2131 Solid carbide Blind hole	52K.65 straight flute PLGANG 30° ASG2350 Solid carbide Blind hole	52Q.17 straight flute PLGANG 60° ASG2170 Solid carbide Blind hole	52H.55 straight flute PLGANG 30° ASG2360 Solid carbide Blind hole

DC +0,004/+0,005 mm	L mm	LU mm	LPR mm	OAL mm	DCONMS _{h6} mm	ZEPF	40 487 ...		40 404 ...		40 478 ...		40 474 ...		40 476 ...	
							£	U4/4R	£	U4/4R	£	U4/4R	£	U4/4R	£	U4/4R
8,02	16	60	65	101	8	6	160.71	08020	176.92	08020 ¹⁾	356.93	08020 ¹⁾	356.93	08020 ¹⁾	356.93	08020 ¹⁾
8,02	16	60	65	101	8	8										
8,03	16	60	65	101	8	6	160.71	08030	176.92	08030 ¹⁾	356.93	08030 ¹⁾	356.93	08030 ¹⁾	356.93	08030 ¹⁾
8,03	16	60	65	101	8	8										
8,04 - 8,05	16	60	65	101	8	6	345.61	xxxxx ²⁾	356.93	xxxxx ¹⁾	356.93	xxxxx ¹⁾	356.93	xxxxx ¹⁾	356.93	xxxxx ¹⁾
8,04 - 8,05	16	60	65	101	8	8										
8,06 - 9,96	16	63	68	108	10	6	439.20	xxxxx ²⁾	515.58	xxxxx ¹⁾	515.58	xxxxx ¹⁾	515.58	xxxxx ¹⁾	515.58	xxxxx ¹⁾
8,06 - 9,96	16	63	68	108	10	8										
9,97	16	63	68	108	10	6	234.21	09970	257.89	09970 ¹⁾	515.58	09970 ¹⁾	515.58	09970 ¹⁾	515.58	09970 ¹⁾
9,97	16	63	68	108	10	8										
9,98	16	63	68	108	10	6	234.21	09980	257.89	09980 ¹⁾	515.58	09980 ¹⁾	515.58	09980 ¹⁾	515.58	09980 ¹⁾
9,98	16	63	68	108	10	8										
9,99	16	63	68	108	10	6	234.21	09990	257.89	09990 ¹⁾	515.58	09990 ¹⁾	515.58	09990 ¹⁾	515.58	09990 ¹⁾
9,99	16	63	68	108	10	8										
10,00	16	63	68	108	10	6	234.21	10000	257.89	10000 ¹⁾	515.58	10000 ¹⁾	515.58	10000 ¹⁾	515.58	10000 ¹⁾
10,00	16	63	68	108	10	8										
10,01	16	63	68	108	10	6	234.21	10010	257.89	10010 ¹⁾	515.58	10010 ¹⁾	515.58	10010 ¹⁾	515.58	10010 ¹⁾
10,01	16	63	68	108	10	8										
10,02	16	63	68	108	10	6	234.21	10020	257.89	10020 ¹⁾	515.58	10020 ¹⁾	515.58	10020 ¹⁾	515.58	10020 ¹⁾
10,02	16	63	68	108	10	8										
10,03	16	63	68	108	10	6	234.21	10030	257.89	10030 ¹⁾	515.58	10030 ¹⁾	515.58	10030 ¹⁾	515.58	10030 ¹⁾
10,03	16	63	68	108	10	8										
10,04 - 10,05	16	63	68	108	10	6	439.20	xxxxx ²⁾	515.58	xxxxx ¹⁾	515.58	xxxxx ¹⁾	515.58	xxxxx ¹⁾	515.58	xxxxx ¹⁾
10,04 - 10,05	16	63	68	108	10	8										
10,06 - 11,96	20	80	85	130	12	6	665.84	xxxxx ²⁾	702.54	xxxxx ¹⁾	702.54	xxxxx ¹⁾	702.54	xxxxx ¹⁾	702.54	xxxxx ¹⁾
10,06 - 11,96	20	80	85	130	12	8										
11,97	20	80	85	130	12	6	312.71	11970	343.87	11970 ¹⁾	702.54	11970 ¹⁾	702.54	11970 ¹⁾	702.54	11970 ¹⁾
11,97	20	80	85	130	12	8										
11,98	20	80	85	130	12	6	312.71	11980	343.87	11980 ¹⁾	702.54	11980 ¹⁾	702.54	11980 ¹⁾	702.54	11980 ¹⁾
11,98	20	80	85	130	12	8										
11,99	20	80	85	130	12	6	312.71	11990	343.87	11990 ¹⁾	702.54	11990 ¹⁾	702.54	11990 ¹⁾	702.54	11990 ¹⁾
11,99	20	80	85	130	12	8										

P	●	●				
M	●	●				
K	●		●			
N	○			●		
S	○					
H	○					●
O						○

- 1) Not available ex stock, articles are non-returnable and cannot be exchanged / Delivery time on request / Minimum order 2 pieces
 2) Not available ex stock, articles are non-returnable and cannot be exchanged / Delivery time on request

→ v_c Page 81+82

This tool concept permits numerous tolerances. For sizes covered please refer to the table on → **page 101**.
 For xxxxx please indicate required Ø in the order (e.g. Ø 8.82 mm → Article No. 40 487 08820)!

Further information on chamfer geometries (ASG) can be found on → **page 100**.

Fullmax – High-performance machine reamers, long

- ▲ extremely irregular pitch
- ▲ designed for high-speed machining
- ▲ specialised geometries and coatings

- ▲ tolerance: $\varnothing 2,96 - 5,96 \text{ mm} = +0,004 \text{ mm}$
- ▲ tolerance: $\varnothing 5,97 - 20,05 \text{ mm} = +0,005 \text{ mm}$

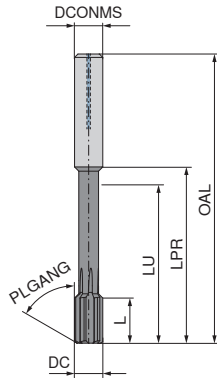

UNI	VA	K	ALU	H
DBG-U	DBQ	DBG-P	DBC-N	DBF-A
52M.57 straight flute PLGANG 60° ASG2110 Solid carbide Blind hole	52T.45 straight flute PLGANG 45° ASG2131 Solid carbide Blind hole	52K.65 straight flute PLGANG 30° ASG2350 Solid carbide Blind hole	52Q.17 straight flute PLGANG 60° ASG2170 Solid carbide Blind hole	52H.55 straight flute PLGANG 30° ASG2360 Solid carbide Blind hole

DC <small>+0,004/+0,005</small> mm	L mm	LU mm	LPR mm	OAL mm	DCONMS _{h6} mm	ZEFP	40 487 ...		40 404 ...		40 478 ...		40 474 ...		40 476 ...	
							£	U4/4R	£	U4/4R	£	U4/4R	£	U4/4R	£	U4/4R
12,00	20	80	85	130	12	6	312.71	12000	343.87	12000 ¹⁾	702.54	12000 ¹⁾	702.54	12000 ¹⁾	702.54	12000 ¹⁾
12,00	20	80	85	130	12	8					702.54	12010 ¹⁾	702.54	12010 ¹⁾	702.54	12010 ¹⁾
12,01	20	80	85	130	12	6	312.71	12010	343.87	12010 ¹⁾	702.54	12010 ¹⁾	702.54	12010 ¹⁾	702.54	12010 ¹⁾
12,01	20	80	85	130	12	8					702.54	12020 ¹⁾	702.54	12020 ¹⁾	702.54	12020 ¹⁾
12,02	20	80	85	130	12	6	312.71	12020	343.87	12020 ¹⁾	702.54	12020 ¹⁾	702.54	12020 ¹⁾	702.54	12020 ¹⁾
12,02	20	80	85	130	12	8					702.54	12030 ¹⁾	702.54	12030 ¹⁾	702.54	12030 ¹⁾
12,03	20	80	85	130	12	6	312.71	12030	343.87	12030 ¹⁾	702.54	12030 ¹⁾	702.54	12030 ¹⁾	702.54	12030 ¹⁾
12,03	20	80	85	130	12	8					702.54	12040 ¹⁾	702.54	12040 ¹⁾	702.54	12040 ¹⁾
12,04 - 12,05	20	80	85	130	12	6	665.84	xxxxx ²⁾	702.54	xxxxx ¹⁾	702.54	xxxxx ¹⁾	702.54	xxxxx ¹⁾	702.54	xxxxx ¹⁾
12,04 - 12,05	20	80	85	130	12	8					702.54	xxxxx ¹⁾	702.54	xxxxx ¹⁾	702.54	xxxxx ¹⁾
12,06 - 14,05	20	80	85	130	14	6	773.49	xxxxx ²⁾	807.46	xxxxx ¹⁾	807.46	xxxxx ¹⁾	807.46	xxxxx ¹⁾	807.46	xxxxx ¹⁾
12,06 - 14,05	20	80	85	130	14	8					807.46	xxxxx ¹⁾	807.46	xxxxx ¹⁾	807.46	xxxxx ¹⁾
14,06 - 16,05	20	97	102	150	16	6	895.18	xxxxx ²⁾	932.11	xxxxx ¹⁾	932.11	xxxxx ¹⁾	932.11	xxxxx ¹⁾	932.11	xxxxx ¹⁾
14,06 - 16,05	20	97	102	150	16	8					932.11	xxxxx ¹⁾	932.11	xxxxx ¹⁾	932.11	xxxxx ¹⁾
16,06 - 18,05	20	97	102	150	18	6	949.12	xxxxx ²⁾	985.84	xxxxx ¹⁾	985.84	xxxxx ¹⁾	985.84	xxxxx ¹⁾	985.84	xxxxx ¹⁾
16,06 - 18,05	20	97	102	150	18	8					985.84	xxxxx ¹⁾	985.84	xxxxx ¹⁾	985.84	xxxxx ¹⁾
18,06 - 20,05	20	105	110	160	20	6	1,028.43	xxxxx ²⁾	1,059.48	xxxxx ¹⁾	1,059.48	xxxxx ¹⁾	1,059.48	xxxxx ¹⁾	1,059.48	xxxxx ¹⁾
18,06 - 20,05	20	105	110	160	20	8					1,059.48	xxxxx ¹⁾	1,059.48	xxxxx ¹⁾	1,059.48	xxxxx ¹⁾

P	•	•				
M	•	•				
K	•		•			
N	○			•		
S	○					
H	○					•
O						○

- 1) Not available ex stock, articles are non-returnable and cannot be exchanged / Delivery time on request / Minimum order 2 pieces → v_c Page 81+82
- 2) Not available ex stock, articles are non-returnable and cannot be exchanged / Delivery time on request

i This tool concept permits numerous tolerances. For sizes covered please refer to the table on → page 101.
For xxxxx please indicate required \varnothing in the order (e.g. $\varnothing 8.82 \text{ mm}$ → Article No. 40 487 08820)!

i Further information on chamfer geometries (ASG) can be found on → page 100.

NC machine reamers, DIN 8093-2B

- ▲ extremely irregular pitch
- ▲ Ø 2–3.5 mm with centres both ends
- ▲ Ø 4–13 mm with protected centres
- ▲ from Ø 22 mm, similar to DIN 8093-2B
- ▲ PLGANG ≤ Ø 3,75 = 30° / > Ø 3,75 = 45°

NC

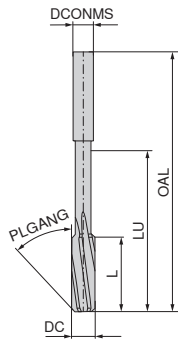

Left Hand Helix
Solid carbide
Through hole

40 420 ...

DC _{H7} mm	L mm	LU mm	OAL mm	DCONMS _{h6} mm	ZEFP	£ U4	
2.0	12	18.5	50	3	4	79.07	020
2.5	16	29.0	60	3	4	79.07	025
3.0	17	33.0	65	4	6	82.32	030
3.2	18	33.0	65	4	6	82.32	032
3.5	18	43.0	75	4	6	82.32	035
4.0	19	43.0	75	4	6	98.57	040
4.5	21	39.0	80	6	6	98.57	045
5.0	23	52.0	93	6	6	110.47	050
5.5	26	53.0	93	6	6	110.47	055
6.0	26	53.0	93	6	6	119.10	060
6.5	28	61.0	101	6	6	119.10	065
7.0	31	68.0	109	8	6	132.09	070
7.5	31	68.0	109	8	6	132.09	075
8.0	33	77.0	117	8	6	153.82	080
8.5	33	77.0	117	8	6	153.82	085
9.0	36	80.0	125	10	6	167.87	090
9.5	36	80.0	125	10	6	167.87	095
10.0	38	88.0	133	10	6	179.80	100
10.5	38	88.0	133	10	6	179.80	105
11.0	41	97.0	142	10	6	231.77	110
12.0	44	100.0	151	12	6	231.77	120
13.0	44	100.0	151	12	6	227.46	130
14.0	47	106.0	160	16	6	227.46	140
15.0	50	108.0	162	16	6	242.64	150
16.0	52	116.0	170	16	6	249.04	160
17.0	52	121.0	175	18	6	255.56	170
18.0	52	128.0	182	18	6	257.76	180
19.0	52	133.0	189	20	6	268.53	190
20.0	52	139.0	195	20	6	270.76	200
22.0	25	105.0	160	20	6	270.76	220
24.0	25	125.0	180	20	8	329.26	240
25.0	25	125.0	180	20	8	329.26	250
26.0	25	125.0	180	20	8	370.40	260
28.0	25	119.0	180	25	8	387.70	280
30.0	25	139.0	200	25	8	400.70	300

P	●
M	○
K	○
N	●
S	○
H	○
O	●

1) with carbide cutting edges

→ v_c Page 84

NC machine reamers, DIN 8093-2B

- ▲ extremely irregular pitch
- ▲ Ø 2–3.5 mm with centres both ends
- ▲ Ø 4–13 mm with protected centres
- ▲ from Ø 22 mm, similar to DIN 8093-2B
- ▲ PLGANG ≤ Ø 3,75 = 30° / > Ø 3,75 = 45°

NC

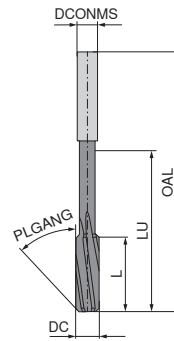

Left Hand Helix
Solid carbide
Through hole

40 421 ...

DC _{H7} mm	L mm	LU mm	OAL mm	DCONMS _{h6} mm	ZEFP	£ U4	
2.0	12	18.5	50	3	4	104.65	020
2.5	16	29.0	60	3	4	104.65	025
3.0	17	33.0	65	4	6	109.11	030
3.2	18	33.0	65	4	6	109.11	032
3.5	18	43.0	75	4	6	109.11	035
4.0	19	43.0	75	4	6	130.55	040
4.5	21	39.0	80	6	6	130.55	045
5.0	23	52.0	93	6	6	146.34	050
5.5	26	53.0	93	6	6	146.34	055
6.0	26	53.0	93	6	6	157.91	060
6.5	28	61.0	101	6	6	157.91	065
7.0	31	68.0	109	8	6	175.09	070
7.5	31	68.0	109	8	6	175.09	075
8.0	33	77.0	117	8	6	203.60	080
8.5	33	77.0	117	8	6	203.60	085
9.0	36	80.0	125	10	6	222.47	090
9.5	36	80.0	125	10	6	222.47	095
10.0	38	88.0	133	10	6	238.01	100
10.5	38	88.0	133	10	6	238.01	105
11.0	41	97.0	142	10	6	306.34	110
12.0	44	100.0	151	12	6	306.34	120
13.0	44	100.0	151	12	6	301.63	130
14.0	47	106.0	160	16	6	301.63	140
15.0	50	108.0	162	16	6	320.47	150
16.0	52	116.0	170	16	6	329.94	160
17.0	52	121.0	175	18	6	339.34	170
18.0	52	128.0	182	18	6	341.73	180
19.0	52	133.0	189	20	6	355.83	190
20.0	52	139.0	195	20	6	358.20	200

P	●
M	○
K	●
N	○
S	○
H	○
O	○

1) with carbide cutting edges

→ v_c Page 84

NC machine reamers, sim. DIN 8093-A

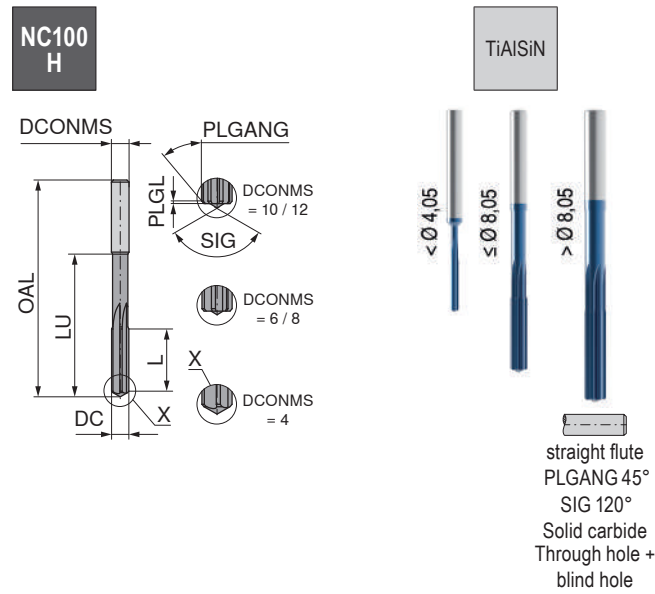

40 435 ...

DC _{H7} mm	L mm	LU mm	OAL mm	DCONMS _{h5} mm	PLGL mm	€ U4/4R	
0.98	6	16	50	4	0.12	110.21	00980
0.99	6	16	50	4	0.12	110.21	00990
1.00	6	16	50	4	0.12	110.21	01000
1.01	6	16	50	4	0.12	110.21	01010
1.02	6	16	50	4	0.12	110.21	01020
1.03	6	16	50	4	0.12	110.21	01030
1.48	9	16	50	4	0.12	120.27	01480
1.49	9	16	50	4	0.12	120.27	01490
1.50	9	16	50	4	0.12	120.27	01500
1.51	9	16	50	4	0.12	120.27	01510
1.52	9	16	50	4	0.12	120.27	01520
1.60	10	16	50	4	0.12	120.27	01600
1.70	10	16	50	4	0.12	120.27	01700
1.80	11	16	50	4	0.12	120.27	01800
1.90	11	16	50	4	0.12	120.27	01900
1.97	12	16	50	4	0.30	120.27	01970
1.98	12	16	50	4	0.30	120.27	01980
1.99	12	16	50	4	0.30	120.27	01990
2.00	12	16	50	4	0.30	120.27	02000
2.01	12	16	50	4	0.30	120.27	02010
2.02	12	16	50	4	0.30	120.27	02020
2.03	12	16	50	4	0.30	120.27	02030
2.05	12	16	50	4	0.30	120.27	02050
2.10	12	16	50	4	0.30	120.27	02100
2.20	13	16	50	4	0.30	120.27	02200
2.30	13	16	50	4	0.30	120.27	02300
2.40	16	26	60	4	0.30	120.27	02400
2.50	16	26	60	4	0.30	120.27	02500
2.60	16	26	60	4	0.30	120.27	02600
2.70	17	30	64	4	0.30	120.27	02700
2.80	17	30	64	4	0.30	120.27	02800
2.90	17	30	64	4	0.30	120.27	02900
2.97	17	30	64	4	0.30	120.27	02970
2.98	17	30	64	4	0.30	120.27	02980
2.99	17	30	64	4	0.30	120.27	02990
3.00	17	30	64	4	0.30	120.27	03000
3.01	17	30	64	4	0.30	120.27	03010
3.02	17	30	64	4	0.30	120.27	03020
3.03	17	30	64	4	0.30	120.27	03030
3.05	18	34	68	4	0.30	120.27	03050
3.10	18	34	68	4	0.30	120.27	03100
3.20	18	34	68	4	0.30	120.27	03200
3.30	18	34	68	4	0.30	120.27	03300
3.40	20	40	74	4	0.30	120.27	03400
3.50	20	40	74	4	0.30	120.27	03500
3.60	20	40	74	4	0.30	120.27	03600
3.70	20	40	74	4	0.30	120.27	03700
3.80	21	43	77	4	0.40	120.27	03800
3.90	21	43	77	4	0.40	120.27	03900
3.97	21	43	77	4	0.40	120.27	03970
3.98	21	43	77	4	0.40	120.27	03980

40 435 ...

DC _{H7} mm	L mm	LU mm	OAL mm	DCONMS _{h5} mm	PLGL mm	€ U4/4R	
3.99	21	43	77	4	0.40	120.27	03990
4.00	21	43	77	4	0.40	120.27	04000
4.01	21	43	77	4	0.40	120.27	04010
4.02	21	43	77	4	0.40	120.27	04020
4.03	21	43	77	4	0.40	120.27	04030
4.05	21	40	82	6	0.40	148.41	04050
4.10	21	40	82	6	0.40	148.41	04100
4.20	21	40	82	6	0.40	148.41	04200
4.30	23	40	82	6	0.40	148.41	04300
4.40	23	40	82	6	0.40	148.41	04400
4.50	23	40	82	6	0.40	148.41	04500
4.60	23	40	82	6	0.40	148.41	04600
4.70	23	40	82	6	0.40	148.41	04700
4.80	26	51	93	6	0.50	148.41	04800
4.90	26	51	93	6	0.50	148.41	04900
4.97	26	51	93	6	0.50	148.41	04970
4.98	26	51	93	6	0.50	148.41	04980
4.99	26	51	93	6	0.50	148.41	04990
5.00	26	51	93	6	0.50	148.41	05000
5.01	26	51	93	6	0.50	148.41	05010
5.02	26	51	93	6	0.50	148.41	05020
5.03	26	51	93	6	0.50	148.41	05030
5.05	26	51	93	6	0.50	148.41	05050
5.10	26	51	93	6	0.50	148.41	05100
5.20	26	51	93	6	0.50	148.41	05200
5.30	26	51	93	6	0.50	148.41	05300
5.40	26	51	93	6	0.50	148.41	05400
5.50	26	51	93	6	0.50	148.41	05500
5.60	26	51	93	6	0.50	148.41	05600
5.70	26	51	93	6	0.50	148.41	05700
5.80	26	51	93	6	0.50	148.41	05800
5.90	26	51	93	6	0.50	148.41	05900
5.97	26	51	93	6	0.50	148.41	05970
5.98	26	51	93	6	0.50	148.41	05980
5.99	26	51	93	6	0.50	148.41	05990
6.00	26	51	93	6	0.50	148.41	06000

P	○
M	○
K	○
N	○
S	○
H	●
O	

→ v. Page 85

This tool concept permits numerous tolerances. Please refer to the table on → page 101 for tolerances covered. Intermediate dimensions available on request.

NC machine reamers, sim. DIN 8093-A

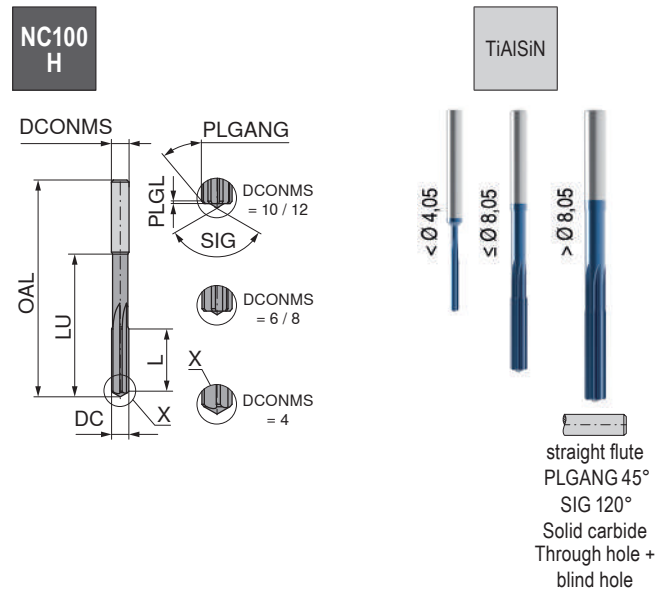

40 435 ...							£	
DC _{H7}	L	LU	OAL	DCONMS _{h5}	PLGL		U4/4R	
mm	mm	mm	mm	mm	mm			
6.01	26	51	93	6	0.5	148.41	06010	
6.02	26	51	93	6	0.5	148.41	06020	
6.03	26	51	93	6	0.5	148.41	06030	
6.05	26	59	101	8	0.5	185.18	06050	
6.10	26	59	101	8	0.5	185.18	06100	
6.20	26	59	101	8	0.5	185.18	06200	
6.30	26	59	101	8	0.5	185.18	06300	
6.40	26	59	101	8	0.5	185.18	06400	
6.50	26	59	101	8	0.5	185.18	06500	
6.60	26	59	101	8	0.5	185.18	06600	
6.70	26	59	101	8	0.5	185.18	06700	
6.80	31	67	109	8	0.6	185.18	06800	
6.85	31	67	109	8	0.6	185.18	06850	
6.90	31	67	109	8	0.6	185.18	06900	
7.00	31	67	109	8	0.6	185.18	07000	
7.10	31	67	109	8	0.6	185.18	07100	
7.20	31	67	109	8	0.6	185.18	07200	
7.30	31	67	109	8	0.6	185.18	07300	
7.40	31	67	109	8	0.6	185.18	07400	
7.50	31	67	109	8	0.6	185.18	07500	
7.60	31	67	109	8	0.6	185.18	07600	
7.70	33	75	117	8	0.6	185.18	07700	
7.80	33	75	117	8	0.6	185.18	07800	
7.90	33	75	117	8	0.6	185.18	07900	
7.97	33	75	117	8	0.6	185.18	07970	
7.98	33	75	117	8	0.6	185.18	07980	
7.99	33	75	117	8	0.6	185.18	07990	
8.00	33	75	117	8	0.6	185.18	08000	
8.01	33	75	117	8	0.7	185.18	08010	
8.02	33	75	117	8	0.7	185.18	08020	
8.03	33	75	117	8	0.7	185.18	08030	
8.05	33	71	117	10	0.7	226.67	08050	
8.10	33	71	117	10	0.7	226.67	08100	
8.20	33	71	117	10	0.7	226.67	08200	
8.30	33	71	117	10	0.7	226.67	08300	
8.40	33	71	117	10	0.7	226.67	08400	
8.50	33	71	117	10	0.7	226.67	08500	
8.60	33	71	117	10	0.7	226.67	08600	
8.70	36	79	125	10	0.7	226.67	08700	
8.80	36	79	125	10	0.7	226.67	08800	
8.90	36	79	125	10	0.7	226.67	08900	
9.00	36	79	125	10	0.7	226.67	09000	
9.10	36	79	125	10	0.7	226.67	09100	
9.20	36	79	125	10	0.7	226.67	09200	
9.30	36	79	125	10	0.7	226.67	09300	
9.40	36	79	125	10	0.7	226.67	09400	
9.50	36	79	125	10	0.7	226.67	09500	
9.60	36	79	125	10	0.7	226.67	09600	
9.70	38	87	133	10	0.7	226.67	09700	
9.80	38	87	133	10	0.7	226.67	09800	
9.90	38	87	133	10	0.7	226.67	09900	

40 435 ...							£	
DC _{H7}	L	LU	OAL	DCONMS _{h5}	PLGL		U4/4R	
mm	mm	mm	mm	mm	mm			
9.97	41	87	133	10	0.7	226.67	09970	
9.98	41	87	133	10	0.7	226.67	09980	
9.99	41	87	133	10	0.7	226.67	09990	
10.00	41	87	133	10	0.7	226.67	10000	
10.01	41	87	133	10	0.7	226.67	10010	
10.02	41	87	133	10	0.8	226.67	10020	
10.03	41	87	133	10	0.8	226.67	10030	
10.04	41	87	133	10	0.8	226.67	10040	
10.05	41	87	133	10	0.8	226.67	10050	
11.17	44	99	150	12	0.8	296.95	11170	
11.97	44	99	150	12	0.8	296.95	11970	
11.98	44	99	150	12	0.8	296.95	11980	
11.99	44	99	150	12	0.8	296.95	11990	
12.00	44	99	150	12	0.8	296.95	12000	
12.01	44	99	150	12	0.8	296.95	12010	
12.02	44	99	150	12	0.8	296.95	12020	
12.03	44	99	150	12	0.8	296.95	12030	
12.04	44	99	150	12	0.8	296.95	12040	
12.05	44	99	150	12	0.8	296.95	12050	

P	○
M	○
K	○
N	
S	
H	●
O	

→ v_c Page 85



This tool concept permits numerous tolerances. Please refer to the table on → page 101 for tolerances covered. Intermediate dimensions available on request.

Machine reamers, DIN 212-B

N

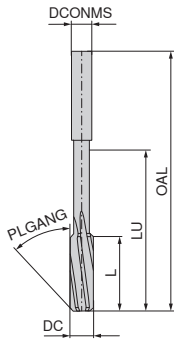

4

Left Hand Helix
PLGANG 45°
HSS-E
Through hole

40 150 ...

DC _{H7} mm	L mm	LU mm	OAL mm	DCONMS _{h9} mm	ZEFP	£ U2	
1.0	5.5	13	34	1.0	3	27.78	010
1.5	8.0	16	40	1.5	3	23.04	015
2.0	11.0	22	49	2.0	4	22.59	020
2.5	14.0	26	57	2.5	4	22.59	025
3.0	15.0	29	61	3.0	6	20.36	030
3.5	18.0	38	70	3.5	6	23.52	035
4.0	19.0	46	75	4.0	6	22.59	040
4.5	21.0	51	80	4.5	6	23.52	045
5.0	23.0	57	86	5.0	6	23.04	050
5.5	26.0	56	93	5.6	6	27.78	055
6.0	26.0	56	93	5.6	6	24.13	060
6.5	28.0	64	101	6.3	6	29.29	065
7.0	31.0	72	109	7.1	6	29.29	070
7.5	31.0	72	109	7.1	6	32.94	075
8.0	33.0	80	117	8.0	6	30.30	080
8.5	33.0	80	117	8.0	6	38.28	085
9.0	36.0	84	125	9.0	6	35.00	090
9.5	36.0	84	125	9.0	6	39.17	095
10.0	38.0	92	133	10.0	6	35.54	100
11.0	41.0	101	142	10.0	6	50.20	110
12.0	44.0	110	151	10.0	6	52.21	120
13.0	44.0	110	151	10.0	6	58.52	130
14.0	47.0	114	160	12.5	8	60.72	140
15.0	50.0	116	162	12.5	8	62.72	150
16.0	52.0	124	170	12.5	8	64.96	160
17.0	54.0	129	175	14.0	8	76.43	170
18.0	56.0	136	182	14.0	8	78.42	180
19.0	58.0	140	189	16.0	8	92.09	190
20.0	60.0	146	195	16.0	8	87.91	200

P	●
M	○
K	●
N	●
S	○
H	
O	●

→ v. Page 88

1 All other diameters, tolerance classes and chamfers also available on request.

Machine reamers, DIN 212-B

- ▲ 0.01 mm steps
- ▲ tolerance: Ø 0.95 – 5.50 mm = +0.004 mm
- ▲ tolerance: Ø 5.51 – 12.00 mm = +0.005 mm

N
100

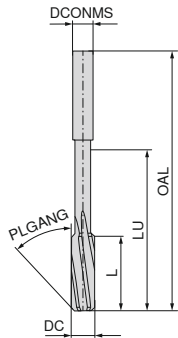

Left Hand Helix
PLGANG 45°
HSS-E
Through hole

DC mm	L mm	LU mm	OAL mm	DCONMS _{hg} mm	ZEFP	£ U2	
0,95 - 1,06	5.5	13	34	1.0	3	30.30	xxxxx ¹⁾
1,07 - 1,18	6.5	14	36	1.1	3	30.30	xxxxx ¹⁾
1,19 - 1,32	7.5	15	38	1.2	3	30.30	xxxxx ¹⁾
1,33 - 1,41	8.0	16	40	1.4	3	30.30	xxxxx ¹⁾
1,42 - 1,47	8.0	16	40	1.5	3	27.78	xxxxx ¹⁾
1,48	8.0	16	40	1.5	3	27.78	01480
1,49	8.0	16	40	1.5	3	27.78	01490
1,50	8.0	16	40	1.5	3	27.78	01500
1,51 - 1,70	9.0	18	43	1.6	3	26.25	xxxxx ¹⁾
1,71 - 1,90	10.0	20	46	1.8	4	26.25	xxxxx ¹⁾
1,91 - 1,97	11.0	22	49	2.0	4	26.25	xxxxx ¹⁾
1,98	11.0	22	49	2.0	4	26.25	01980
1,99	11.0	22	49	2.0	4	26.25	01990
2,00	11.0	22	49	2.0	4	24.63	02000
2,01	11.0	22	49	2.0	4	24.63	02010
2,02	11.0	22	49	2.0	4	24.63	02020
2,03	11.0	22	49	2.0	4	24.63	02030
2,04	11.0	22	49	2.0	4	24.63	02040
2,05	11.0	22	49	2.0	4	24.63	02050
2,06 - 2,09	11.0	22	49	2.0	4	24.63	xxxxx ¹⁾
2,10 - 2,12	11.0	22	49	2.0	4	28.20	xxxxx ¹⁾
2,13 - 2,36	12.0	24	53	2.2	4	28.20	xxxxx ¹⁾
2,37 - 2,49	14.0	26	57	2.5	4	28.20	xxxxx ¹⁾
2,50 - 2,59	14.0	26	57	2.5	4	24.13	xxxxx ¹⁾
2,60 - 2,65	14.0	26	57	2.5	4	29.29	xxxxx ¹⁾
2,66 - 2,80	15.0	30	61	2.8	6	29.29	xxxxx ¹⁾
2,81 - 2,94	15.0	29	61	3.0	6	29.29	xxxxx ¹⁾
2,95	15.0	29	61	3.0	6	29.29	02950 ¹⁾
2,96	15.0	29	61	3.0	6	29.29	02960 ¹⁾
2,97	15.0	29	61	3.0	6	29.29	02970
2,98	15.0	29	61	3.0	6	29.29	02980
2,99	15.0	29	61	3.0	6	29.29	02990
3,00	15.0	29	61	3.0	6	29.29	03000
3,01	16.0	33	65	3.2	6	21.99	03010
3,02	16.0	33	65	3.2	6	21.99	03020
3,03	16.0	33	65	3.2	6	21.99	03030
3,04	16.0	33	65	3.2	6	21.99	03040
3,05	16.0	33	65	3.2	6	21.99	03050
3,06	16.0	33	65	3.2	6	21.99	03060
3,07	16.0	33	65	3.2	6	21.99	03070
3,08 - 3,09	16.0	33	65	3.2	6	21.99	xxxxx ¹⁾
3,10 - 3,35	16.0	33	65	3.2	6	27.78	xxxxx ¹⁾
3,36 - 3,49	18.0	38	70	3.5	6	27.78	xxxxx ¹⁾
3,50 - 3,59	18.0	38	70	3.5	6	24.13	xxxxx ¹⁾
3,60 - 3,75	18.0	38	70	3.5	6	30.90	xxxxx ¹⁾
3,76 - 3,81	19.0	46	75	4.0	6	30.90	xxxxx ¹⁾
3,82 - 3,94	19.0	46	75	4.0	6	23.52	xxxxx ¹⁾
3,95	19.0	46	75	4.0	6	23.52	03950 ¹⁾
3,96	19.0	46	75	4.0	6	23.52	03960 ¹⁾
3,97	19.0	46	75	4.0	6	23.52	03970

40 140 ...

DC mm	L mm	LU mm	OAL mm	DCONMS _{hg} mm	ZEFP	£ U2	
3,98	19.0	46	75	4.0	6	23.52	03980
3,99	19.0	46	75	4.0	6	23.52	03990
4,00	19.0	46	75	4.0	6	23.52	04000
4,01	19.0	46	75	4.0	6	23.52	04010
4,02	19.0	46	75	4.0	6	23.52	04020
4,03	19.0	46	75	4.0	6	23.52	04030
4,04	19.0	46	75	4.0	6	23.52	04040
4,05	19.0	46	75	4.0	6	23.52	04050
4,06	19.0	46	75	4.0	6	23.52	04060
4,07	19.0	46	75	4.0	6	23.52	04070
4,08	19.0	46	75	4.0	6	23.52	04080
4,09 - 4,20	19.0	46	75	4.0	6	23.52	xxxxx ¹⁾
4,21 - 4,25	19.0	46	75	4.0	6	28.84	xxxxx ¹⁾
4,26 - 4,75	21.0	51	80	4.5	6	28.84	xxxxx ¹⁾
4,76 - 4,95	23.0	57	86	5.0	6	25.63	xxxxx ¹⁾
4,96	23.0	57	86	5.0	6	25.63	04960 ¹⁾
4,97	23.0	57	86	5.0	6	25.63	04970
4,98	23.0	57	86	5.0	6	25.63	04980
4,99	23.0	57	86	5.0	6	25.63	04990
5,00	23.0	57	86	5.0	6	25.63	05000
5,01	23.0	57	86	5.0	6	25.63	05010
5,02	23.0	57	86	5.0	6	25.63	05020
5,03	23.0	57	86	5.0	6	25.63	05030
5,04	23.0	57	86	5.0	6	25.63	05040
5,05	23.0	57	86	5.0	6	25.63	05050
5,06	23.0	57	86	5.0	6	25.63	05060
5,07	23.0	57	86	5.0	6	25.63	05070
5,08 - 5,20	23.0	57	86	5.0	6	25.63	xxxxx ¹⁾
5,21 - 5,30	23.0	57	86	5.0	6	28.20	xxxxx ¹⁾
5,31 - 5,94	26.0	56	93	5.6	6	28.20	xxxxx ¹⁾
5,95	26.0	56	93	5.6	6	28.20	05950 ¹⁾
5,96	26.0	56	93	5.6	6	28.20	05960 ¹⁾
5,97	26.0	56	93	5.6	6	28.20	05970
5,98	26.0	56	93	5.6	6	28.20	05980
5,99	26.0	56	93	5.6	6	28.20	05990

P	●
M	○
K	●
N	●
S	○
H	
O	●

→ v_c Page 88

1) Not available ex stock, articles are non-returnable and cannot be exchanged / Delivery time 16 working days

This tool concept permits numerous tolerances. For achievable tolerances covered, please see the table on → page 101. For xxxxx please indicate required Ø in the order (e.g. Ø 10.06 mm → Article no. 40 140 10060)!

All other diameters, tolerance classes and chamfers also available on request.

Machine reamers, DIN 212-B

- ▲ 0.01 mm steps
- ▲ tolerance: Ø 0.95 – 5.50 mm = +0.004 mm
- ▲ tolerance: Ø 5.51 – 12.00 mm = +0.005 mm

N
100

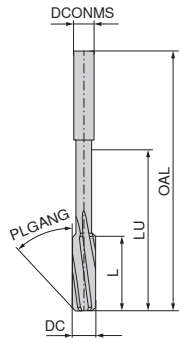

Left Hand Helix
PLGANG 45°
HSS-E
Through hole

DC	L	LU	OAL	DCONMS	h ₉	ZEPF	£	
mm	mm	mm	mm	mm	mm		U2	
6,00	26	56	93	5.6	6		28.20	06000
6,01	28	64	101	6.3	6		30.90	06010
6,02	28	64	101	6.3	6		30.90	06020
6,03	28	64	101	6.3	6		30.90	06030
6,04	28	64	101	6.3	6		30.90	06040
6,05	28	64	101	6.3	6		30.90	06050
6,06 - 6,11	28	64	101	6.3	6		30.90	xxxxx ¹⁾
6,12 - 6,34	28	64	101	6.3	6		30.90	xxxxx ¹⁾
6,35	28	64	101	6.3	6		30.90	06350
6,36 - 6,70	28	64	101	6.3	6		30.90	xxxxx ¹⁾
6,71 - 6,94	31	72	109	7.1	6		30.90	xxxxx ¹⁾
6,95	31	72	109	7.1	6		30.90	06950 ¹⁾
6,96	31	72	109	7.1	6		30.90	06960 ¹⁾
6,97	31	72	109	7.1	6		30.90	06970 ¹⁾
6,98	31	72	109	7.1	6		30.90	06980 ¹⁾
6,99	31	72	109	7.1	6		30.90	06990 ¹⁾
7,00	31	72	109	7.1	6		30.90	07000 ¹⁾
7,01	31	72	109	7.1	6		30.90	07010 ¹⁾
7,02	31	72	109	7.1	6		30.90	07020 ¹⁾
7,03	31	72	109	7.1	6		30.90	07030 ¹⁾
7,04 - 7,50	31	72	109	7.1	6		30.90	xxxxx ¹⁾
7,51 - 7,94	33	80	117	8.0	6		30.90	xxxxx ¹⁾
7,95	33	80	117	8.0	6		30.90	07950 ¹⁾
7,96	33	80	117	8.0	6		30.90	07960 ¹⁾
7,97	33	80	117	8.0	6		30.90	07970
7,98	33	80	117	8.0	6		30.90	07980
7,99	33	80	117	8.0	6		30.90	07990
8,00	33	80	117	8.0	6		30.90	08000
8,01	33	80	117	8.0	6		30.90	08010
8,02	33	80	117	8.0	6		30.90	08020
8,03	33	80	117	8.0	6		30.90	08030
8,04	33	80	117	8.0	6		30.90	08040
8,05	33	80	117	8.0	6		30.90	08050
8,06 - 8,20	33	80	117	8.0	6		30.90	xxxxx ¹⁾
8,21 - 8,50	33	80	117	8.0	6		38.70	xxxxx ¹⁾
8,51 - 8,63	36	84	125	9.0	6		38.70	xxxxx ¹⁾
8,64 - 8,95	36	84	125	9.0	6		38.70	xxxxx ¹⁾
8,96	36	84	125	9.0	6		38.70	08960 ¹⁾
8,97	36	84	125	9.0	6		38.70	08970 ¹⁾
8,98	36	84	125	9.0	6		38.70	08980 ¹⁾
8,99	36	84	125	9.0	6		38.70	08990 ¹⁾
9,00	36	84	125	9.0	6		38.70	09000 ¹⁾
9,01	36	84	125	9.0	6		38.70	09010 ¹⁾
9,02	36	84	125	9.0	6		38.70	09020 ¹⁾
9,03 - 9,50	36	84	125	9.0	6		38.70	xxxxx ¹⁾
9,51 - 9,63	38	92	133	10.0	6		38.70	xxxxx ¹⁾
9,64 - 9,95	38	92	133	10.0	6		38.70	xxxxx ¹⁾
9,96	38	92	133	10.0	6		38.70	09960 ¹⁾
9,97	38	92	133	10.0	6		38.70	09970
9,98	38	92	133	10.0	6		38.70	09980

40 140 ...

DC	L	LU	OAL	DCONMS	h ₉	ZEPF	£	
mm	mm	mm	mm	mm	mm		U2	
9,99	38	92	133	10.0	6		38.70	09990
10,00	38	92	133	10.0	6		38.70	10000
10,01	38	92	133	10.0	6		38.70	10010
10,02	38	92	133	10.0	6		38.70	10020
10,03	38	92	133	10.0	6		38.70	10030
10,04	38	92	133	10.0	6		38.70	10040
10,05	38	92	133	10.0	6		38.70	10050
10,06 - 10,09	38	92	133	10.0	6		38.70	xxxxx ¹⁾
10,10	38	92	133	10.0	6		38.70	10100
10,11 - 10,19	38	92	133	10.0	6		38.70	xxxxx ¹⁾
10,20	38	92	133	10.0	6		38.70	10200
10,21 - 10,60	38	92	133	10.0	6		48.55	xxxxx ¹⁾
10,61 - 11,20	41	101	142	10.0	6		48.55	xxxxx ¹⁾
11,21 - 11,80	41	101	142	10.0	6		55.41	xxxxx ¹⁾
11,81 - 11,95	44	110	151	10.0	6		55.41	xxxxx ¹⁾
11,96	44	110	151	10.0	6		55.41	11960 ¹⁾
11,97	44	110	151	10.0	6		55.41	11970
11,98	44	110	151	10.0	6		55.41	11980
11,99	44	110	151	10.0	6		55.41	11990
12,00	44	110	151	10.0	6		55.41	12000
12,01 - 12,05	44	110	151	10.0	6		55.41	xxxxx ¹⁾

P	●
M	○
K	●
N	●
S	○
H	●
O	●

→ v_c Page 88

1) Not available ex stock, articles are non-returnable and cannot be exchanged / Delivery time 16 working days

i This tool concept permits numerous tolerances. For achievable tolerances covered, please see the table on → page 101. For xxxxx please indicate required Ø in the order (e.g. Ø 10.06 mm → Article no. 40 140 10060)!

i All other diameters, tolerance classes and chamfers also available on request.

Stub reamers, DIN 8089-B

AR

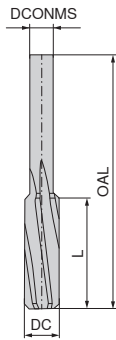

Left Hand Helix
PLGANG 45°
HSS-E
Through hole

40 145 ...

DC _{H7} mm	L mm	OAL mm	DCONMS _{H8} mm	ZEPF	£ U2	
4	20	56	3.55	6	23.41	040
5	22	63	4.00	6	25.63	050
6	22	63	5.00	6	25.63	060
8	25	71	6.30	6	30.61	080
10	25	71	8.00	6	37.27	100
12	28	80	10.00	6	54.50	120
14	32	90	12.50	8	62.25	140
16	32	90	12.50	8	67.90	160
18	36	100	16.00	8	82.27	180
20	36	100	16.00	8	90.01	200

P	●
M	○
K	●
N	●
S	○
H	○
O	●

→ v_c Page 88

All other diameters, tolerance classes and chamfers also available on request.

Stub reamers, DIN 8089-B

- ▲ 0.01 mm steps
- ▲ tolerance: Ø 3.76 – 5.50 mm = +0.004 mm
- ▲ tolerance: Ø 5.51 – 12.00 mm = +0.005 mm

AR
100

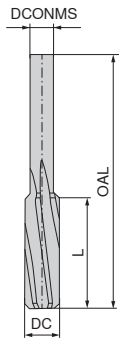

Left Hand Helix
PLGANG 45°
HSS-E
Through hole

DC mm	L mm	OAL mm	DCONMS _{h8} mm	ZEFP	£ U2	
3,76 - 3,81	20	56	3.55	6	33.95	xxxxx ¹⁾
3,82 - 3,94	20	56	3.55	6	25.07	xxxxx ¹⁾
3,95	20	56	3.55	6	25.07	03950 ¹⁾
3,96	20	56	3.55	6	25.07	03960 ¹⁾
3,97	20	56	3.55	6	25.07	03970 ¹⁾
3,98	20	56	3.55	6	25.07	03980 ¹⁾
3,99	20	56	3.55	6	25.07	03990 ¹⁾
4,00	20	56	3.55	6	25.07	04000 ¹⁾
4,01	20	56	3.55	6	25.07	04010 ¹⁾
4,02	20	56	3.55	6	25.07	04020 ¹⁾
4,03 - 4,20	20	56	3.55	6	25.07	xxxxx ¹⁾
4,21 - 4,25	20	56	3.55	6	30.04	xxxxx ¹⁾
4,26 - 4,75	22	63	4.00	6	30.04	xxxxx ¹⁾
4,76 - 4,94	22	63	4.00	6	26.67	xxxxx ¹⁾
4,95	22	63	4.00	6	26.67	04950 ¹⁾
4,96	22	63	4.00	6	26.67	04960 ¹⁾
4,97	22	63	4.00	6	26.67	04970 ¹⁾
4,98	22	63	4.00	6	26.67	04980 ¹⁾
4,99	22	63	4.00	6	26.67	04990 ¹⁾
5,00	22	63	4.00	6	26.67	05000 ¹⁾
5,01	22	63	4.00	6	26.67	05010 ¹⁾
5,02	22	63	4.00	6	26.67	05020 ¹⁾
5,03	22	63	4.00	6	26.67	05030 ¹⁾
5,04	22	63	4.00	6	26.67	05040 ¹⁾
5,05	22	63	4.00	6	26.67	05050 ¹⁾
5,06 - 5,20	22	63	4.00	6	26.67	xxxxx ¹⁾
5,21 - 5,30	22	63	4.00	6	30.04	xxxxx ¹⁾
5,31 - 5,70	22	63	5.00	6	30.04	xxxxx ¹⁾
5,71 - 5,94	22	63	5.00	6	30.04	xxxxx ¹⁾
5,95	22	63	5.00	6	30.04	05950 ¹⁾
5,96	22	63	5.00	6	30.04	05960 ¹⁾
5,97	22	63	5.00	6	30.04	05970 ¹⁾
5,98	22	63	5.00	6	30.04	05980 ¹⁾
5,99	22	63	5.00	6	30.04	05990 ¹⁾
6,00	22	63	5.00	6	30.04	06000 ¹⁾
6,01	22	63	5.00	6	30.04	06010 ¹⁾
6,02	22	63	5.00	6	30.04	06020 ¹⁾
6,03 - 6,11	22	63	5.00	6	30.04	xxxxx ¹⁾
6,12 - 6,70	22	63	5.00	6	32.27	xxxxx ¹⁾
6,71 - 6,94	25	71	6.30	6	32.27	xxxxx ¹⁾
6,95	25	71	6.30	6	32.27	06950 ¹⁾
6,96	25	71	6.30	6	32.27	06960 ¹⁾
6,97	25	71	6.30	6	32.27	06970 ¹⁾
6,98	25	71	6.30	6	32.27	06980 ¹⁾
6,99	25	71	6.30	6	32.27	06990 ¹⁾
7,00	25	71	6.30	6	32.27	07000 ¹⁾
7,01	25	71	6.30	6	32.27	07010 ¹⁾
7,02	25	71	6.30	6	32.27	07020 ¹⁾
7,03 - 7,25	25	71	6.30	6	32.27	xxxxx ¹⁾
7,26 - 7,94	25	71	6.30	6	32.27	xxxxx ¹⁾
7,95	25	71	6.30	6	32.27	07950 ¹⁾
7,96	25	71	6.30	6	32.27	07960 ¹⁾

40 139 ...

DC mm	L mm	OAL mm	DCONMS _{h8} mm	ZEFP	£ U2	
7,97	25	71	6.30	6	32.27	07970 ¹⁾
7,98	25	71	6.30	6	32.27	07980 ¹⁾
7,99	25	71	6.30	6	32.27	07990 ¹⁾
8,00	25	71	6.30	6	32.27	08000 ¹⁾
8,01	25	71	6.30	6	32.27	08010 ¹⁾
8,02	25	71	6.30	6	32.27	08020 ¹⁾
8,03	25	71	6.30	6	32.27	08030 ¹⁾
8,04	25	71	6.30	6	32.27	08040 ¹⁾
8,05 - 8,20	25	71	6.30	6	32.27	xxxxx ¹⁾
8,21 - 8,50	25	71	6.30	6	40.65	xxxxx ¹⁾
8,51 - 8,94	25	71	8.00	6	40.65	xxxxx ¹⁾
8,95	25	71	8.00	6	40.65	08950 ¹⁾
8,96	25	71	8.00	6	40.65	08960 ¹⁾
8,97	25	71	8.00	6	40.65	08970 ¹⁾
8,98	25	71	8.00	6	40.65	08980 ¹⁾
8,99	25	71	8.00	6	40.65	08990 ¹⁾
9,00	25	71	8.00	6	40.65	09000 ¹⁾
9,01	25	71	8.00	6	40.65	09010 ¹⁾
9,02	25	71	8.00	6	40.65	09020 ¹⁾
9,03 - 9,25	25	71	8.00	6	40.65	xxxxx ¹⁾
9,26 - 9,94	25	71	8.00	6	40.65	xxxxx ¹⁾
9,95	25	71	8.00	6	40.65	09950 ¹⁾
9,96	25	71	8.00	6	40.65	09960 ¹⁾
9,97	25	71	8.00	6	40.65	09970 ¹⁾
9,98	25	71	8.00	6	40.65	09980 ¹⁾
9,99	25	71	8.00	6	40.65	09990 ¹⁾
10,00	25	71	8.00	6	40.65	10000 ¹⁾
10,01	25	71	8.00	6	40.65	10010 ¹⁾
10,02	25	71	8.00	6	40.65	10020 ¹⁾
10,03 - 10,20	25	71	8.00	6	40.65	xxxxx ¹⁾
10,21 - 10,60	25	71	8.00	6	51.72	xxxxx ¹⁾
10,61 - 11,20	28	80	10.00	6	51.72	xxxxx ¹⁾
11,21 - 11,25	28	80	10.00	6	60.03	xxxxx ¹⁾
11,26 - 11,94	28	80	10.00	6	60.03	xxxxx ¹⁾
11,95	28	80	10.00	6	60.03	11950 ¹⁾
11,96	28	80	10.00	6	60.03	11960 ¹⁾
11,97	28	80	10.00	6	60.03	11970 ¹⁾
11,98	28	80	10.00	6	60.03	11980 ¹⁾
11,99	28	80	10.00	6	60.03	11990 ¹⁾
12,00	28	80	10.00	6	60.03	12000 ¹⁾

P	●
M	○
K	●
N	●
S	○
H	
O	●

→ v_c Page 88

1) Not available ex stock, articles are non-returnable and cannot be exchanged /
Delivery time 16 working days

This tool concept permits numerous tolerances.
For achievable tolerances covered, please see the table on → page 101.
For xxxxx please indicate required Ø in the order
(e.g. Ø 10.06 mm → Article no. 40 139 10060!)

All other diameters, tolerance classes and chamfers also available on request.

Machine reamers HSS-E DIN 208

▲ the circular land on the cutting edge burnishes the hole and guides the reamer

N

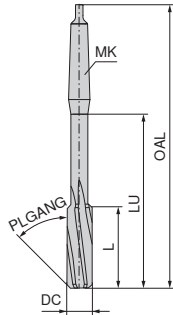

DC _{H7} mm	L mm	LU mm	OAL mm	MK	ZEPF	£ U2	
16	52	127	210	2	8	77.72	160
17	54	132	214	2	8	83.44	170
18	56	137	219	2	8	86.72	180
19	58	142	223	2	8	91.20	190
20	60	147	228	2	8	91.20	200
21	62	151	232	2	8	103.39	210
22	64	156	237	2	8	103.39	220
23	66	160	241	2	8	118.90	230
24	68	167	268	3	8	122.38	240
25	68	167	268	3	8	125.73	250
26	70	172	273	3	8	134.67	260
27	71	177	277	3	10	149.02	270
28	71	177	277	3	10	149.02	280
29	73	181	281	3	10	166.87	290
30	73	181	281	3	10	154.64	300
32	77	190	317	4	10	202.35	320
34	78	194	321	4	10	225.68	340
35	78	195	321	4	10	225.68	350
36	79	200	325	4	10	245.67	360
38	81	204	329	4	10	270.12	380
40	81	204	329	4	10	272.40	400
42	82	211	333	4	12	297.99	420
44	83	215	336	4	12	351.32	440
50	86	224	344	4	12	445.77	500

P	●
M	○
K	●
N	●
S	○
H	
O	●

→ v_c Page 88

Hand reamers, DIN 206-B

▲ PLGANG ≤ Ø 3,5 = 30°; > Ø 3,5 = 45°/30°

H

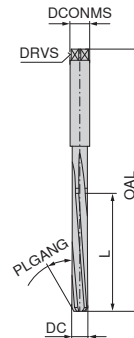

DC _{H7} mm	L mm	OAL mm	DRVS mm	DCONMS mm	ZEPF	£ U2	
3.0	31	62	2.24	3.0	6	32.85	030
3.2	33	66	2.50	3.2	6	40.65	032
3.5	35	71	2.80	3.5	6	38.38	035
4.0	38	76	3.15	4.0	6	27.89	040
4.5	41	81	3.55	4.5	6	33.95	045
5.0	44	87	4.00	5.0	6	32.85	050
5.5	47	93	4.50	5.5	6	35.00	055
6.0	47	93	4.50	6.0	6	31.73	060
7.0	54	107	5.60	7.0	6	34.53	070
8.0	58	115	6.30	8.0	6	36.17	080
9.0	62	124	7.10	9.0	6	40.65	090
10.0	66	133	8.00	10.0	6	40.65	100
11.0	71	142	9.00	11.0	6	45.06	110
12.0	76	152	10.00	12.0	6	48.39	120
13.0	76	152	10.00	13.0	6	71.21	130
14.0	81	163	11.20	14.0	8	77.72	140
15.0	81	163	11.20	15.0	8	82.27	150
16.0	87	175	12.50	16.0	8	85.81	160
17.0	87	175	14.00	17.0	8	90.01	170
18.0	93	188	14.00	18.0	8	100.10	180
19.0	93	188	14.00	19.0	8	107.90	190
20.0	100	201	16.00	20.0	8	105.73	200
22.0	107	215	18.00	22.0	8	122.38	220
24.0	115	231	20.00	24.0	8	141.24	240
25.0	115	231	20.00	25.0	8	144.53	250
26.0	115	231	20.00	26.0	8	154.64	260
28.0	124	247	22.40	28.0	10	197.88	280
30.0	124	247	22.40	30.0	10	208.03	300

P	●
M	○
K	●
N	●
S	○
H	
O	●

1 All other diameters, tolerance classes and chamfers also available on request.

Insert countersink 180°

Scope of supply:

Indexable insert countersink including clamping screws

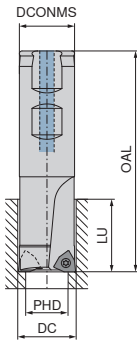

NEW



30 198 ...

DC mm	PHD mm	ZEFP	ZNF	DCONMS mm	LU mm	OAL mm	Insert	£ U1/4D	
10	5.3	1	1	16	10	80	WOEX 030204	307.17	01000 ¹⁾
11	6.4	1	1	16	11	80	WOEX 030204	307.17	01100 ¹⁾
15	8.4	1	1	16	15	80	WOEX 05T304	307.17	01500
18	10.4	1	1	16	18	80	WOEX 05T304	178.00	01800
20	13.0	1	1	25	20	100	WOEX 05T304	350.75	02000
24	15.0	2	2	25	24	100	WOEX 05T304	496.79	02400
26	17.0	2	2	25	26	100	WOEX 05T304	496.79	02600
30	19.0	2	2	25	30	100	WOEX 06T304	507.69	03000
33	21.0	2	2	25	33	100	WOEX 080404	509.99	03300
36	21.0	2	2	25	36	100	WOEX 080404	518.59	03600
40	25.0	2	2	25	40	100	WOEX 080404	531.78	04000
48	28.0	2	2	32	48	120	WOEX 100504	579.56	04800

1) Without Through Coolant

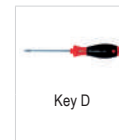

Key D



Clamping screw

Spare parts DC	80 950 ...		10 950 ...	
	£ Y7		£ W7/6B	
10 - 11	T06 - IP	17.37 123	M2,0x4,3 - 06IP	2.73 10000
15 - 26	T08 - IP	17.13 125	M2,5x7,2 - 08IP	2.73 10500
30	T10 - IP	19.45 127	M3,5x7,3 - 10IP	2.73 10600
33 - 48	T15 - IP	20.03 128	M4,5x9 - 15IP	2.93 12700

WOEX

Designation	L mm	IC mm	S mm	D1 mm
WOEX 0302..	3.2	5	2.30	2.30
WOEX 05T3..	5.3	8	3.80	2.85
WOEX 06T3..	6.6	10	3.80	4.05
WOEX 0804..	7.9	12	4.80	4.90
WOEX 1005..	9.9	15	5.30	4.90

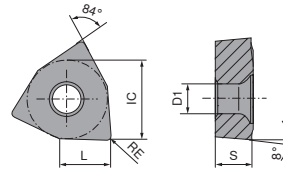

WOEX

ISO	RE mm	-01 K10		-01 BK8425	
		£		£	
030204	0.4	9.71	35301	13.10	30301
05T304	0.4	10.68	35501	14.28	30501
06T304	0.4	11.88	35601	15.96	30601
080404	0.4	16.09	35801	20.16	30801
100504	0.4	21.85	36001	27.49	31001
P					●
M					●
K					●
N					○
S					●
H					○
O					●

→ v_c Page 89

Indexable chamfer milling 90°

Scope of supply:

Indexable insert countersink including clamping screws

WPS

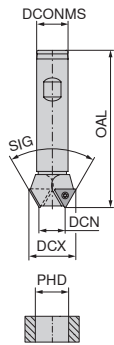

30 196 ...

DCX mm	DCN mm	PHD mm	ZEFP	ZNF	DCONMS mm	OAL mm	Insert	£	
19	7	9.5	2	2	16	100	TOHX 090204	466.40	19000
23	11	12.0	2	2	16	100	TOHX 090204	472.91	23000
26	11	12.0	1	2	16	100	TOHX 090204	477.30	26000
30	12	13.0	2	2	20	100	TOHX 140305	499.08	30000
34	16	17.0	2	2	20	100	TOHX 140305	507.69	34000
37	19	20.0	2	2	20	100	TOHX 140305	507.69	37000



TORX® Screws

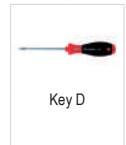

Key D

62 950 ...

80 950 ...

Spare parts			£		£	
DCX			W7/6B		Y7	
19 - 26		M2,6x6,2 - 08IP	2.98	09900	T08 - IP	17.13 125
30 - 37		M3,5x7,3 - 10IP	2.83	12600	T10 - IP	19.45 127

Indexable chamfer milling 60°

Scope of supply:

Indexable insert countersink including clamping screws

WPS

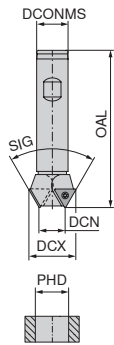

30 197 ...

DCX mm	DCN mm	PHD mm	ZEFP	ZNF	DCONMS mm	OAL mm	Insert	£	
16.5	8.1	8.5	1	1	16	100	TOHX 090204	472.91	16500
20.0	11.6	12.0	2	2	16	100	TOHX 090204	477.30	20000
22.0	13.6	14.0	2	2	16	100	TOHX 090204	499.08	22000
23.5	15.1	15.5	2	2	16	100	TOHX 090204	507.69	23500
25.5	17.1	17.5	2	2	16	100	TOHX 090204	507.69	25500



TORX® Screws

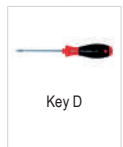

Key D

62 950 ...

80 950 ...

Spare parts

DCX		£		£	
16,5 - 22	M2,6x5,2 - 08IP	2.98	12000	T08 - IP	17.13 125
23,5 - 25,5	M2,6x6,2 - 08IP	2.98	09900	T08 - IP	17.13 125

TOHX

Designation	L mm	IC mm	S mm	D1 mm
TOHX 0902..	9.12	5.6	2.50	2.8
TOHX 1403..	13.62	8.2	3.00	3.8

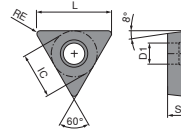

TOHX

4

	-G06 BK8425	-U877 BK8425	-G12 BK8425
	F TOHX	F TOHX	F TOHX
	62 602 ...	62 604 ...	62 603 ...
	£ 1A/3#	£ 1A/3#	£ 1A/3#
	28.58 33000	24.72 31400	25.45 31400

ISO	RE mm
090204EN	0.4
140305EN	0.5

P	●	●	●
M	●	●	●
K	●	●	●
N	○	○	○
S	●	●	●
H	○	○	○
O			

→ v_c Page 89

TOHX

ISO	RE mm
090204EN	0.4
090204FN	0.4
140305FN	0.5

P			
M			
K			
N		●	●
S		●	●
H			
O		●	●

→ v_c Page 89

Counterbore, DIN 373

- ▲ with fixed pilot
- ▲ with 3 cutting edges, right-hand flutes for counterbores according to DIN 74
- ▲ for countersinking to suit hexagon socket screws according to DIN 912, DIN 6912, DIN 7984 and cap screws according to DIN 84

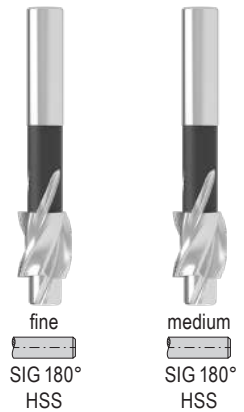
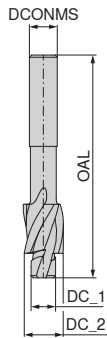

Thread	DC_2 _{z9} mm	DCONMS _{h9} mm	OAL mm	DC_1 _{e8} mm	30 190 ...		30 191 ...	
					£ U1		£ U1	
M3	6	5.0	71	3.2	26.40	030 ¹⁾	26.40	030 ¹⁾
M3	6	5.0	71	3.4				
M4	8	5.0	71	4.3	23.18	040 ¹⁾	23.18	040 ¹⁾
M4	8	5.0	71	4.5				
M5	10	8.0	80	5.3	25.30	050 ¹⁾	25.30	050 ¹⁾
M5	10	8.0	80	5.5				
M6	11	8.0	80	6.4	26.99	060 ¹⁾	26.99	060 ¹⁾
M6	11	8.0	80	6.6				
M8	15	12.5	100	8.4	43.72	080 ¹⁾	43.72	080 ¹⁾
M8	15	12.5	100	9.0				
M10	18	12.5	100	10.5	52.23	100 ¹⁾	52.23	100 ¹⁾
M10	18	12.5	100	11.0				
M12	20	12.5	100	13.0	56.83	120	56.83	120
M12	20	12.5	100	13.5				
P						●		●
M						●		●
K						●		●
N						●		●
S						○		○
H								
O						●		●

1) Included in the set

→ v. Page 94

Counterbore, DIN 373 – Set

Scope of supply:

Counterbores M3; M4; M5; M6; M8; M10 in case



30 190 ...		30 191 ...	
£ U1		£ U1	
232.04	999	232.04	999

Countersink 90° with irregular pitch, DIN 335-C

- ▲ all sizes with 3 cutting edges and highly irregular pitch, resulting in smooth running, excellent roundness and chatter reduction giving the highest surface quality
- ▲ special HPC-TiN coating
- ▲ for very high tool life in almost all materials
- ▲ greatly reduced axial and radial forces
- ▲ for countersinking to DIN 7991

N

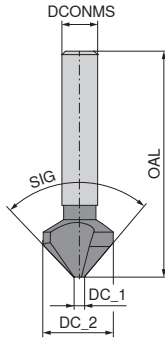

NEW

HPC-TiN



SIG 90°

Solid carbide

30 117 ...

DC_2 ₂₉ mm	DC_1 mm	DCONMS _{h9} mm	OAL mm	DIN 7991	£ U1	
6.3	1.5	5	45	M3	309.39	06300
8.3	2.0	6	50	M4	332.39	08300
10.4	2.5	6	50	M5	346.98	10400 ¹⁾
12.4	2.8	8	56	M6	364.11	12400
16.5	3.2	10	60	M8	445.61	16500 ¹⁾
20.5	3.5	10	60	M10	511.91	20500
25.0	3.8	10	67	M12	590.24	25000 ¹⁾
31.0	4.2	12	71	M16	699.67	31000

P	●
M	○
K	●
N	●
S	○
H	○
O	○

1) Included in the set

→ v_c Page 91

Countersink 90° with irregular pitch, DIN 335-C – Set

Scope of supply:

Countersinks Ø 10.4 / 16.5 / 25.0 mm in storage case

N



NEW

HPC-TiN

30 117 ...

£
U1
1,500.82 99900

Countersink 60° factory standard-C

▲ with 3 cutting edges for countersinking and deburring in high-tensile steels, grey cast iron, aluminium alloys containing silicon and corrosion resistant steels.

N

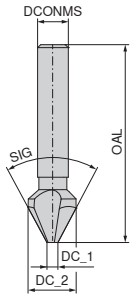

SIG 60°
Solid carbide

30 160 ...

DC_2 _{z9} mm	DC_1 mm	DCONMS _{h9} mm	OAL mm	£ U1	
12.5	3.2	8	56	303.29	125
16.0	4.0	10	63	412.79	160
20.0	5.0	10	67	478.77	200
25.0	6.3	10	71	534.02	250

P	●
M	○
K	●
N	●
S	○
H	○
O	

→ v_c Page 90

Countersink 90° factory standard-C

▲ with 3 cutting edges for countersinking and deburring in high-tensile steels, grey cast iron, aluminium alloys containing silicon and corrosion resistant steels.

N

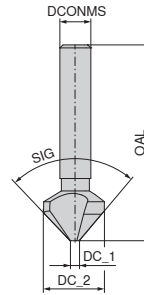

SIG 90°
Solid carbide

30 115 ...

DC_2 _{z9} mm	DC_1 mm	DCONMS _{h9} mm	OAL mm	DIN ISO 7721	DIN 7991	£ U1	
10.4	2.5	8	46	M5		210.48	100
12.4	2.8	8	56		M6	210.48	124
15.0	3.2	10	60	M8		259.36	150
16.5	3.2	10	60		M8	274.86	165
20.5	3.5	10	63		M10	327.97	205
25.0	3.8	10	67		M12	376.67	250
31.0	4.2	12	71		M16	502.84	310

P	●
M	○
K	●
N	●
S	○
H	○
O	

→ v_c Page 90

Countersink 90° with irregular pitch, DIN 335-C

- ▲ all sizes with 3 cutting edges and highly irregular pitch, resulting in smooth running, excellent roundness and chatter reduction giving the highest surface quality
- ▲ for very high tool life in almost all materials
- ▲ greatly reduced axial and radial forces
- ▲ for countersinking to DIN ISO 7721 and DIN 7991

N

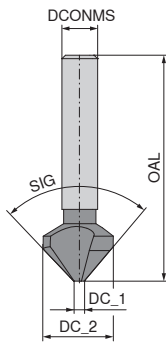

NEW

TiN



SIG 90°
HSS

30 141 ...

DC_2 _{z9} mm	DC_1 mm	DCONMS _{h9} mm	OAL mm	DIN ISO 7721	DIN 7991	£ U1	
4.3	1.3	4	40	M2		49.07	04300
6.0	1.5	5	45	M3		49.71	06000
6.3	1.5	5	45		M3	49.71	06300
8.0	2.0	6	50	M4		57.48	08000
8.3	2.0	6	50		M4	57.48	08300
10.0	2.5	6	50	M5		63.46	10000
10.4	2.5	6	50		M5	68.64	10400 ¹⁾
11.5	2.8	8	56	M6		70.48	11500
12.4	2.8	8	56		M6	75.45	12400
15.0	3.2	10	60	M8		87.28	15000
16.5	3.2	10	60		M8	92.14	16500 ¹⁾
19.0	3.5	10	63	M10		113.56	19000
20.5	3.5	10	63		M10	118.11	20500
23.0	3.8	10	67	M12		150.69	23000
25.0	3.8	10	67		M12	154.27	25000 ¹⁾
31.0	4.2	12	71		M16	192.05	31000

P	●
M	○
K	●
N	●
S	○
H	○
O	○

1) Included in the set

Countersink 90° with irregular pitch, DIN 335-C – Set

Scope of supply:

Countersinks Ø 10.4 / 16.5 / 25.0 mm in storage case

N



NEW

TiN

30 141 ...

£
U1
327.00 99900

Countersink 90°, DIN 335-C

- ▲ 3 cutting edges to avoid burrs and chatter marks when countersinking and deburring in virtually all materials. Particularly suitable for DIN screws according to DIN ISO 7721 and 7991, as the countersink diameters are matched to the heads of these screws.
- ▲ the TiN version makes high cutting rates possible; very long tool life and very good friction resistance properties in order to avoid material sticking.
- ▲ TiAlN version shows considerably improved performance compared to TiN version. Particularly suitable for all abrasive materials (cast iron, AISi) and/or at high temperature.

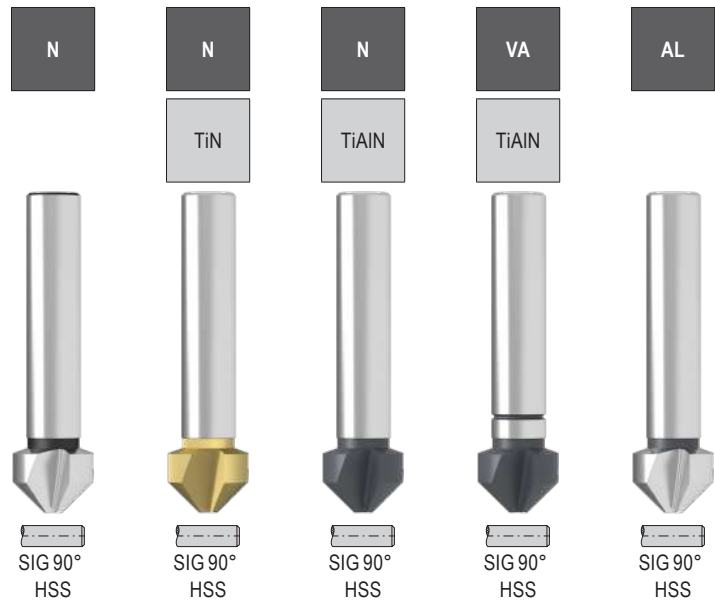
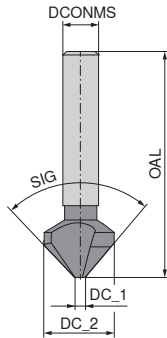

DC_2 ₂₉ mm	DC_1 mm	DCONMS mm	OAL mm	DIN ISO 7721	DIN 7991	30 100 ...		30 110 ...		30 130 ...		30 132 ...		30 102 ...	
						£ U1		£ U1		£ U1		£ U1		£ U1	
4.3	1.3	4	40	M2		15.51	043								
5.0	1.5	4	40	M2.5		15.51	050	29.49	050	40.19	050				
6.0	1.5	5	45	M3		15.51	060								
6.3	1.5	5	45		M3	15.51	063	29.49	063	41.15	063	25.81	063	17.69	063
7.0	1.8	6	50	M3.5		16.69	070								
8.0	2.0	6	50	M4		17.21	080	35.25	080	43.00	080				
8.3	2.0	6	50		M4	18.44	083	35.25	083	42.56	083	30.56	083	18.68	083
9.4	2.2	6	50			19.02	094								
10.0	2.5	6	50	M5		20.39	100	38.38	100	45.06	100				
10.4	2.5	6	50		M5	21.00	104	40.89	104	46.83	104	43.15	104	21.65	104
11.5	2.8	8	56	M6		21.53	115								
12.4	2.8	8	56		M6	22.28	124	45.06	124	59.61	124	37.58	124	23.04	124
13.4	2.9	8	56			23.98	134								
15.0	3.2	10	60	M8		26.57	150	48.18	150	76.22	150	46.46	150	26.02	150
16.5	3.2	10	60		M8	28.95	165	55.92	165	78.62	165	50.32	165	27.99	165
19.0	3.5	10	63	M10		36.59	190								
20.5	3.5	10	63		M10	38.38	205	78.22	205	102.58	205	59.81	205	38.53	205
23.0	3.8	10	67	M12		48.53	230								
25.0	3.8	10	67		M12	51.29	250	107.19	250	146.48	250	77.97	250	51.22	250
31.0	4.2	12	71		M16	78.22	310	138.90	310	199.81	310	115.80	310		310
31.0	4.2	12	67		M16									82.25	310
P							●		●		●		○		○
M							○		○		○		●		○
K							●		●		●		○		○
N							●		●		●		○		●
S							○		○		○		○		○
H									○		○		○		
O							●		●		●		●		●

1) Included in the set

→ v_c Page 92+93

Countersink 90°, DIN 335-C – set

Scope of supply:

Countersinks Ø 6,3; 8,3; 10,4; 12,4; 16,5; 20,5 in case



30 100 ...		30 110 ...	
£ U1		£ U1	
149.42	999	298.68	999

Countersink 60°, DIN 334-C

▲ 3 cutting edges for countersinking and deburring in virtually all materials

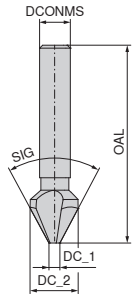

SIG 60°
HSS

30 150 ...

DC_2 ²⁹ mm	DC_1 mm	DCONMS ^{h9} mm	OAL mm	£ U1	
6.3	1.6	5	45	17.91	063 ¹⁾
8.0	2.0	6	50	17.91	080 ¹⁾
10.0	2.5	6	52	22.07	100 ¹⁾
12.5	3.2	8	56	22.60	125 ¹⁾
16.0	4.0	10	63	28.25	160 ¹⁾
20.0	5.0	10	67	40.79	200 ¹⁾
25.0	6.3	10	71	53.56	250

P	●
M	○
K	●
N	●
S	○
H	
O	●

1) Included in the set

→ v_c Page 94

Countersink 90°, DIN 335-C

▲ 3 cutting edges to avoid burrs and chatter marks when countersinking and deburring in virtually all materials. Particularly suitable for DIN screws according to DIN ISO 7721 and 7991, as the countersink diameters are matched to the heads of these screws.

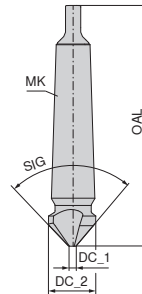

SIG 90°
HSS

30 105 ...

DC_2 ²⁹ mm	DC_1 mm	OAL mm	MK	£ U1	
30	4.2	112	2	83.06	300
31	4.2	112	2	88.77	310
34	4.5	118	2	88.77	340
37	4.8	118	2	115.31	370
40	10.0	140	3	131.83	400
50	14.0	150	3	163.58	500
63	16.0	180	4	258.97	630
80	22.0	190	4	439.06	800

P	●
M	○
K	●
N	●
S	○
H	
O	●

→ v_c Page 94

Countersink 60°, DIN 334-C – set

Scope of supply:

Countersinks Ø 6,3; 8,0; 10,0; 12,5; 16,0; 20,0 in case



30 150 ...

£ U1	
165.85	999

Countersink 120°, factory standard-C

▲ 3 cutting edges for countersinking and deburring in virtually all materials

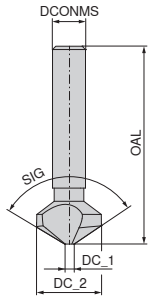

SIG 120°
HSS

DC_2 _{z9} mm	DC_1 mm	DCONMS _{h9} mm	OAL mm	£ U1	
6.3	1.5	5	45	21.58	063
8.3	2.0	6	50	21.58	083
10.4	2.5	6	50	23.98	104
12.4	2.8	8	56	25.17	124
16.5	3.2	10	60	36.59	165
20.5	3.5	10	60	50.35	205
25.0	3.8	10	63	62.72	250

P	●
M	○
K	●
N	●
S	○
H	○
O	●

→ v_c Page 94

Deburring countersink 90°, factory standard-A

▲ with angled hole to avoid burrs and chattermarks when countersinking and deburring in soft long-chipping materials, e.g. aluminium, plastics etc.

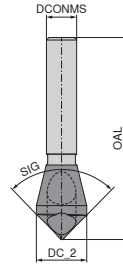

SIG 90°
HSS-E



SIG 90°
HSS-E

DC_2 mm	PHD mm	DCONMS _{h9} mm	OAL mm	£ U1		£ U1	
6.3	1 - 4	6.3	45	34.36	040 ¹⁾	49.85	040 ¹⁾
10.0	2 - 5	6.0	45	21.52	050	32.41	050
14.0	5 - 10	8.0	48	26.13	101	46.83	101
21.0	10 - 15	10.0	65	44.92	150	76.22	150
28.0	15 - 20	12.0	85	94.32	200	154.77	200

P	●	●
M	○	○
K	●	●
N	●	●
S	○	○
H	○	○
O	●	●

1) can be used in both directions

→ v_c Page 95

Material examples for cutting data tables

	Material sub-group	Index	Composition / Structure / Heat treatment	Tensile strength N/mm ² / HB / HRC	Material number	Material designation	Material number	Material designation
P	Unalloyed steel	P.1.1	< 0,15 % C Annealed	420 N/mm ² / 125 HB	1.0401	C15	1.1141	Ck15
		P.1.2	< 0,45 % C Annealed	640 N/mm ² / 190 HB	1.1191	C45E	1.0718	9SMnPb28
		P.1.3	< 0,45 % C Tempered	840 N/mm ² / 250 HB	1.1191	C45E	1.0535	C55
		P.1.4	< 0,75 % C Annealed	910 N/mm ² / 270 HB	1.1223	C60R	1.0535	C55
		P.1.5	< 0,75 % C Tempered	1010 N/mm ² / 300 HB	1.1223	C60R	1.0727	45S20
	Low-alloy steel	P.2.1	Annealed	610 N/mm ² / 180 HB	1.7131	16MnCr5	1.6587	17CrNiMo6
		P.2.2	Tempered	930 N/mm ² / 275 HB	1.7131	16MnCr5	1.6587	17CrNiMo6
		P.2.3	Tempered	1010 N/mm ² / 300 HB	1.7225	42CrMo4	1.3505	100Cr6
		P.2.4	Tempered	1200 N/mm ² / 375 HB	1.7225	42CrMo4	1.3505	100Cr6
	High-alloy steel and high-alloy tool steel	P.3.1	Annealed	680 N/mm ² / 200 HB	1.4021	X20Cr13	1.4034	X46Cr13
		P.3.2	Hardened and tempered	1100 N/mm ² / 300 HB	1.2343	X38CrMoV5-1	1.4034	X46Cr13
		P.3.3	Hardened and tempered	1300 N/mm ² / 400 HB	1.2343	X38CrMoV5-1	1.4034	X46Cr13
	Stainless steel	P.4.1	Ferritic / martensitic Annealed	680 N/mm ² / 200 HB	1.4016	X6Cr17	1.2316	X36CrMo16
		P.4.2	Martensitic Tempered	1010 N/mm ² / 300 HB	1.4112	X90CrMoV18	1.2316	X36CrMo16
M	Stainless steel	M.1.1	Austenitic / austenitic-ferritic Quenched	610 N/mm ² / 180 HB	1.4301	X5CrNi18-10	1.4571	X6CrNiMoTi17-12-2
		M.2.1	Austenitic Tempered	300 HB	1.4841	X15CrNiSi25-21	1.4539	X1NiCrMoCu25-20-5
		M.3.1	Austenitic / ferritic (Duplex)	780 N/mm ² / 230 HB	1.4462	X2CrNiMoN22-5-3	1.4501	X2CrNiMoCuWN25-7-4
K	Grey cast iron	K.1.1	Pearlitic / ferritic	350 N/mm ² / 180 HB	0.6010	GG-10	0.6025	GG-25
		K.1.2	Pearlitic (martensitic)	500 N/mm ² / 260 HB	0.6030	GG-30	0.6045	GG-45
	Spherulitic graphite cast iron	K.2.1	Ferritic	540 N/mm ² / 160 HB	0.7040	GGG-40	0.7060	GGG-60
		K.2.2	Pearlitic	845 N/mm ² / 250 HB	0.7070	GGG-70	0.7080	GGG-80
	Malleable iron	K.3.1	Ferritic	440 N/mm ² / 130 HB	0.8035	GTW-35-04	0.8045	GTW-45
		K.3.2	Pearlitic	780 N/mm ² / 230 HB	0.8165	GTS-65-02	0.8170	GTS-70-02
N	Aluminium wrought alloy	N.1.1	Non-hardenable	60 HB	3.0255	Al99,5	3.3315	AlMg1
		N.1.2	Hardenable Age-hardened	340 N/mm ² / 100 HB	3.1355	AlCuMg2	3.2315	AlMgSi1
	Cast aluminium alloy	N.2.1	≤ 12 % Si, non-hardenable	250 N/mm ² / 75 HB	3.2581	G-AlSi12	3.2163	G-AlSi9Cu3
		N.2.2	≤ 12 % Si, hardenable Age-hardened	300 N/mm ² / 90 HB	3.2134	G-AlSi5Cu1Mg	3.2373	G-AlSi9Mg
		N.2.3	> 12 % Si, non-hardenable	440 N/mm ² / 130 HB		G-AlSi17Cu4Mg		G-AlSi18CuNiMg
	Copper and copper alloys (bronze/brass)	N.3.1	Free-machining alloys, PB > 1 %	375 N/mm ² / 110 HB	2.0380	CuZn39Pb2 (Ms58)	2.0410	CuZn44Pb2
		N.3.2	CuZn, CuSnZn	300 N/mm ² / 90 HB	2.0331	CuZn15	2.4070	CuZn28Sn1As
		N.3.3	CuSn, lead-free copper and electrolytic copper	340 N/mm ² / 100 HB	2.0060	E-Cu57	2.0590	CuZn40Fe
	Magnesium alloys	N.4.1	Magnesium and magnesium alloys	70 HB	3.5612	MgAl6Zn	3.5312	MgAl3Zn
	S	Heat-resistant alloys	S.1.1	Fe - basis Annealed	680 N/mm ² / 200 HB	1.4864	X12NiCrSi 36-16	1.4865
S.1.2			Fe - basis Age-hardened	950 N/mm ² / 280 HB	1.4980	X6NiCrTiMoVB25-15-2	1.4876	X10NiCrAlTi32-20
S.2.1			Ni or Co basis Annealed	840 N/mm ² / 250 HB	2.4631	NiCr20TiAl (Nimonic80A)	3.4856	NiCr22Mo9Nb
S.2.2			Ni or Co basis Age-hardened	1180 N/mm ² / 350 HB	2.4668	NiCr19Nb5Mo3 (Inconel 718)	2.4955	NiFe25Cr20NbTi
S.2.3			Ni or Co basis Cast	1080 N/mm ² / 320 HB	2.4765	CoCr20W15Ni	1.3401	G-X120Mn12
Titanium alloys		S.3.1	Pure titanium	400 N/mm ²	3.7025	Ti99,8	3.7034	Ti99,7
		S.3.2	Alpha + beta alloys Age-hardened	1050 N/mm ² / 320 HB	3.7165	TiAl6V4	Ti-6246	Ti-6Al-2Sn-4Zr-6Mo
S.3.3	Beta alloys	1400 N/mm ² / 410 HB	Ti555.3	Ti-5Al-5V-5Mo-3Cr	R56410	Ti-10V-2Fe-3Al		
H	Hardened steel	H.1.1	Hardened and tempered	46–55 HRC				
		H.1.2	Hardened and tempered	56–60 HRC				
		H.1.3	Hardened and tempered	61–65 HRC				
		H.1.4	Hardened and tempered	66–70 HRC				
	Chilled iron	H.2.1	Cast	400 HB				
Hardened cast iron	H.3.1	Hardened and tempered	55 HRC					
O	Non-metal materials	O.1.1	Plastics, duroplastic	≤ 150 N/mm ²				
		O.1.2	Plastics, thermoplastic	≤ 100 N/mm ²				
		O.2.1	Aramid fibre-reinforced	≤ 1000 N/mm ²				
		O.2.2	Glass/carbon-fibre reinforced	≤ 1000 N/mm ²				
		O.3.1	Graphite					

* Tensile strength

Cutting data standard values for REAMAX TS

Index	40 577 ..., 40 585 ...						40 521 ..., 40 571 ...								
	75J.65, 75H.65 – ASG3000 / HM-DBG-P						75J.65, 75H.65 – ASG0106 / HM-DBG-P								
	Nominal Ø in mm ▶		18–21,999	22–31,799	31,8–51,999	52–65		Nominal Ø in mm ▶		18–21,999	22–31,799	31,8–51,999	52–65		
	Reaming allowance Ø ▶		0,20–0,30	0,20–0,30	0,30–0,40	0,30–0,50		Reaming allowance Ø ▶		0,20–0,30	0,20–0,30	0,30–0,40	0,30–0,50		
	Number of flutes ▶		6	6	8	10		Number of flutes ▶		6	6	8	10		
3xD		5xD		f (mm/rev)				3xD		5xD		f (mm/rev)			
v _c (m/min)		v _c (m/min)		f (mm/rev)				v _c (m/min)		v _c (m/min)		f (mm/rev)			
P.1.1	150 (130–200)	120 (100–160)	0,80–1,10	1,00–1,40	1,30–1,90	1,90–2,80									
P.1.2	150 (130–200)	120 (100–160)	0,80–1,10	1,00–1,40	1,30–1,90	1,90–2,80									
P.1.3	150 (130–200)	120 (100–160)	0,80–1,10	1,00–1,40	1,30–1,90	1,90–2,80									
P.1.4	150 (130–200)	120 (100–160)	0,80–1,10	1,00–1,40	1,30–1,90	1,90–2,80									
P.1.5	150 (130–200)	120 (100–160)	0,80–1,10	1,00–1,40	1,30–1,90	1,90–2,80									
P.2.1	150 (130–200)	120 (100–160)	0,80–1,10	1,00–1,40	1,30–1,90	1,90–2,80									
P.2.2	150 (130–200)	120 (100–160)	0,80–1,10	1,00–1,40	1,30–1,90	1,90–2,80									
P.2.3	150 (130–200)	120 (100–160)	0,80–1,10	1,00–1,40	1,30–1,90	1,90–2,80									
P.2.4	150 (130–200)	120 (100–160)	0,80–1,10	1,00–1,40	1,30–1,90	1,90–2,80									
P.3.1							30 (25–50)	30 (25–40)	0,60–0,90	0,80–1,10	1,10–1,50	1,50–2,30			
P.3.2							30 (25–50)	30 (25–40)	0,60–0,90	0,80–1,10	1,10–1,50	1,50–2,30			
P.3.3							30 (25–50)	30 (25–40)	0,60–0,90	0,80–1,10	1,10–1,50	1,50–2,30			
P.4.1							45 (35–60)	40 (35–50)	0,60–0,90	0,80–1,10	1,10–1,50	1,50–2,30			
P.4.2							45 (35–60)	40 (35–50)	0,60–0,90	0,80–1,10	1,10–1,50	1,50–2,30			
M.1.1							45 (35–60)	40 (30–50)	0,60–0,90	0,80–1,10	1,10–1,50	1,50–2,30			
M.2.1							45 (35–60)	40 (30–50)	0,60–0,90	0,80–1,10	1,10–1,50	1,50–2,30			
M.3.1							30 (25–50)	30 (25–40)	0,60–0,90	0,80–1,10	1,10–1,50	1,50–2,30			
K.1.1	150 (130–220)	120 (100–150)	0,90–1,30	1,20–1,70	1,60–2,30	2,30–3,40									
K.1.2	150 (130–220)	120 (100–150)	0,90–1,30	1,20–1,70	1,60–2,30	2,30–3,40									
K.2.1	175 (150–300)	150 (130–180)	0,90–1,30	1,20–1,70	1,60–2,30	2,30–3,40									
K.2.2	120 (100–180)	120 (100–150)	0,80–1,10	1,00–1,40	1,30–1,90	1,90–2,80									
K.3.1	120 (100–180)	120 (100–150)	0,80–1,10	1,00–1,40	1,30–1,90	1,90–2,80									
K.3.2	120 (100–180)	120 (100–150)	0,80–1,10	1,00–1,40	1,30–1,90	1,90–2,80									
N.1.1															
N.1.2															
N.2.1															
N.2.2															
N.2.3															
N.3.1															
N.3.2															
N.3.3															
N.4.1															
S.1.1															
S.1.2															
S.2.1															
S.2.2															
S.2.3															
S.3.1															
S.3.2															
S.3.3															
H.1.1															
H.1.2															
H.1.3															
H.1.4															
H.2.1															
H.3.1															
O.1.1															
O.1.2															
O.2.1															
O.2.2															
O.3.1															

 The cutting data depend extremely on the external conditions, the material and machine type. The indicated values are possible values which have to be increased or reduced, inside the bracket, according to the application conditions.

Cutting data standard values for REAMAX TS

Index	40 526 ..., 40 580 ...						40 539 ...							
	75J.17, 75H.17 – ASG0706 / HM-DBC						75H.93 – ASG3000 / DST							
	Nominal Ø in mm ▶		18–21,999	22–31,799	31,8–51,999	52–65		Nominal Ø in mm ▶		18–21,999	22–31,799	31,8–51,999	52–65	
	Reaming allowance Ø ▶		0,20–0,30	0,20–0,30	0,30–0,40	0,30–0,50		Reaming allowance Ø ▶		0,20–0,30	0,20–0,30	0,30–0,40	0,30–0,50	
	Number of flutes ▶		6	6	8	10		Number of flutes ▶		6	6	8	10	
3xD		5xD		f (mm/rev)		3xD		5xD		f (mm/rev)		f (mm/rev)		
v _c (m/min)		f (mm/rev)		v _c (m/min)		f (mm/rev)		v _c (m/min)		f (mm/rev)		f (mm/rev)		
P.1.1							150 (130–200)	120 (100–160)	0,80–1,10	1,00–1,40	1,30–1,90	1,90–2,80		
P.1.2							150 (130–200)	120 (100–160)	0,80–1,10	1,00–1,40	1,30–1,90	1,90–2,80		
P.1.3							150 (130–200)	120 (100–160)	0,80–1,10	1,00–1,40	1,30–1,90	1,90–2,80		
P.1.4							150 (130–200)	120 (100–160)	0,80–1,10	1,00–1,40	1,30–1,90	1,90–2,80		
P.1.5							150 (130–200)	120 (100–160)	0,80–1,10	1,00–1,40	1,30–1,90	1,90–2,80		
P.2.1							150 (130–200)	120 (100–160)	0,80–1,10	1,00–1,40	1,30–1,90	1,90–2,80		
P.2.2							150 (130–200)	120 (100–160)	0,80–1,10	1,00–1,40	1,30–1,90	1,90–2,80		
P.2.3							150 (130–200)	120 (100–160)	0,80–1,10	1,00–1,40	1,30–1,90	1,90–2,80		
P.2.4							150 (130–200)	120 (100–160)	0,80–1,10	1,00–1,40	1,30–1,90	1,90–2,80		
P.3.1														
P.3.2														
P.3.3														
P.4.1														
P.4.2														
M.1.1														
M.2.1														
M.3.1														
K.1.1														
K.1.2														
K.2.1							175 (150–300)	150 (130–180)	0,90–1,30	1,20–1,70	1,60–2,30	2,30–3,40		
K.2.2							120 (100–150)	100 (80–120)	0,80–1,10	1,00–1,40	1,30–1,90	1,90–2,80		
K.3.1							120 (100–180)	120 (100–150)	0,80–1,10	1,00–1,40	1,30–1,90	1,90–2,80		
K.3.2							120 (100–180)	120 (100–150)	0,80–1,10	1,00–1,40	1,30–1,90	1,90–2,80		
N.1.1	150 (130–300)	150 (130–200)	0,90–1,30	1,10–1,70	1,50–2,30	2,20–3,40								
N.1.2	150 (130–300)	150 (130–200)	0,90–1,30	1,10–1,70	1,50–2,30	2,20–3,40								
N.2.1	200 (180–300)	150 (130–200)	0,90–1,30	1,10–1,70	1,50–2,30	2,20–3,40								
N.2.2	200 (180–300)	150 (130–200)	0,90–1,30	1,10–1,70	1,50–2,30	2,20–3,40								
N.2.3	200 (180–300)	150 (130–200)	0,90–1,30	1,10–1,70	1,50–2,30	2,20–3,40								
N.3.1							150 (130–320)	150 (130–200)	0,90–1,30	1,10–1,70	1,50–2,30	2,10–3,10		
N.3.2							150 (130–320)	150 (130–200)	0,90–1,30	1,10–1,70	1,50–2,30	2,10–3,10		
N.3.3														
N.4.1	150 (180–300)	150 (130–200)	0,90–1,30	1,10–1,70	1,50–2,30	2,20–3,40								
S.1.1														
S.1.2														
S.2.1														
S.2.2														
S.2.3														
S.3.1														
S.3.2														
S.3.3														
H.1.1														
H.1.2														
H.1.3														
H.1.4														
H.2.1														
H.3.1														
O.1.1														
O.1.2														
O.2.1														
O.2.2														
O.3.1	250 (220–270)	250 (220–270)	0,90–1,30	1,10–1,70	1,50–2,30	2,20–3,40								

4

 The cutting data depend extremely on the external conditions, the material and machine type. The indicated values are possible values which have to be increased or reduced, inside the bracket, according to the application conditions.

Cutting data standard values for REAMAX TS

Index	40 544 ...						40 597 ...					
	75J.93 – ASG3000 / DST						75J.93 – ASG4000 / DST					
	Nominal Ø in mm ▶		18–21,999	22–31,799	31,8–51,999	52–65	Nominal Ø in mm ▶		18–21,999	22–31,799	31,8–51,999	52–65
	Reaming allowance Ø ▶		0,20–0,30	0,20–0,30	0,30–0,40	0,30–0,50	Reaming allowance Ø ▶		0,20–0,30	0,20–0,30	0,30–0,40	0,30–0,50
	Number of flutes ▶		6	6	8	10	Number of flutes ▶		6	6	8	10
	3xD		5xD		f (mm/rev)		3xD		5xD		f (mm/rev)	
v _c (m/min)		v _c (m/min)		f (mm/rev)		v _c (m/min)		v _c (m/min)		f (mm/rev)		
P.1.1	150 (130–200)	120 (100–160)	0,80–1,10	1,00–1,40	1,30–1,90	1,90–2,80	150 (130–200)	120 (100–160)	1,00–1,30	1,20–1,70	1,70–2,30	2,40–3,40
P.1.2	150 (130–200)	120 (100–160)	0,80–1,10	1,00–1,40	1,30–1,90	1,90–2,80	150 (130–200)	120 (100–160)	1,00–1,30	1,20–1,70	1,70–2,30	2,40–3,40
P.1.3	150 (130–200)	120 (100–160)	0,80–1,10	1,00–1,40	1,30–1,90	1,90–2,80	150 (130–200)	120 (100–160)	1,00–1,30	1,20–1,70	1,70–2,30	2,40–3,40
P.1.4	150 (130–200)	120 (100–160)	0,80–1,10	1,00–1,40	1,30–1,90	1,90–2,80	150 (130–200)	120 (100–160)	1,00–1,30	1,20–1,70	1,70–2,30	2,40–3,40
P.1.5	150 (130–200)	120 (100–160)	0,80–1,10	1,00–1,40	1,30–1,90	1,90–2,80	150 (130–200)	120 (100–160)	1,00–1,30	1,20–1,70	1,70–2,30	2,40–3,40
P.2.1	150 (130–200)	120 (100–160)	0,80–1,10	1,00–1,40	1,30–1,90	1,90–2,80	150 (130–200)	120 (100–160)	1,00–1,30	1,20–1,70	1,70–2,30	2,40–3,40
P.2.2	150 (130–200)	120 (100–160)	0,80–1,10	1,00–1,40	1,30–1,90	1,90–2,80	150 (130–200)	120 (100–160)	1,00–1,30	1,20–1,70	1,70–2,30	2,40–3,40
P.2.3	150 (130–200)	120 (100–160)	0,80–1,10	1,00–1,40	1,30–1,90	1,90–2,80	150 (130–200)	120 (100–160)	1,00–1,30	1,20–1,70	1,70–2,30	2,40–3,40
P.2.4	150 (130–200)	120 (100–160)	0,80–1,10	1,00–1,40	1,30–1,90	1,90–2,80	150 (130–200)	120 (100–160)	1,00–1,30	1,20–1,70	1,70–2,30	2,40–3,40
P.3.1												
P.3.2												
P.3.3												
P.4.1												
P.4.2												
M.1.1												
M.2.1												
M.3.1												
K.1.1												
K.1.2												
K.2.1	175 (150–300)	150 (130–180)	0,90–1,30	1,20–1,70	1,60–2,30	2,30–3,40	225 (200–300)	180 (160–240)	1,20–1,60	1,50–2,00	2,00–2,70	2,90–4,10
K.2.2	120 (100–150)	100 (80–120)	0,80–1,10	1,00–1,40	1,30–1,90	1,90–2,80	120 (100–150)	100 (80–120)	1,20–1,60	1,50–2,00	2,00–2,70	2,90–4,10
K.3.1	120 (100–180)	120 (100–150)	0,80–1,10	1,00–1,40	1,30–1,90	1,90–2,80						
K.3.2	120 (100–180)	120 (100–150)	0,80–1,10	1,00–1,40	1,30–1,90	1,90–2,80	120 (100–180)	120 (100–150)	1,00–1,30	1,20–1,70	1,70–2,30	2,40–3,40
N.1.1												
N.1.2												
N.2.1												
N.2.2												
N.2.3												
N.3.1	150 (130–320)	150 (130–200)	0,90–1,30	1,10–1,70	1,50–2,30	2,10–3,10						
N.3.2	150 (130–320)	150 (130–200)	0,90–1,30	1,10–1,70	1,50–2,30	2,10–3,10						
N.3.3												
N.4.1												
S.1.1												
S.1.2												
S.2.1												
S.2.2												
S.2.3												
S.3.1												
S.3.2												
S.3.3												
H.1.1												
H.1.2												
H.1.3												
H.1.4												
H.2.1												
H.3.1												
O.1.1												
O.1.2												
O.2.1												
O.2.2												
O.3.1												

 The cutting data depend extremely on the external conditions, the material and machine type. The indicated values are possible values which have to be increased or reduced, inside the bracket, according to the application conditions.

Cutting data standard values for REAMAX

Index	40 560 ...						40 551 ...					
	640.65 – ASG3000 / HM-DBG-P						640.65 – ASG0106 / HM-DBG-P					
	Nominal Ø in mm ▶		12–21,999	22–32,000	32,001–40		Nominal Ø in mm ▶		12–21,999	22–32,000	32,001–40	
	Reaming allowance Ø ▶		0,10–0,30	0,20–0,40	0,20–0,40		Reaming allowance Ø ▶		0,10–0,30	0,20–0,40	0,20–0,40	
	Number of flutes ▶		6	8	8		Number of flutes ▶		6	8	8	
	3xD	5xD	f (mm/rev)			3xD	5xD	f (mm/rev)				
	v _c (m/min)		f (mm/rev)			v _c (m/min)		f (mm/rev)				
P.1.1	150 (130–200)	120 (100–160)	0,90–1,20	1,50–2,00	1,50–2,00							
P.1.2	150 (130–200)	120 (100–160)	0,90–1,20	1,50–2,00	1,50–2,00							
P.1.3	150 (130–200)	120 (100–160)	0,90–1,20	1,50–2,00	1,50–2,00							
P.1.4	150 (130–200)	120 (100–160)	0,90–1,20	1,50–2,00	1,50–2,00							
P.1.5	150 (130–200)	120 (100–160)	0,90–1,20	1,50–2,00	1,50–2,00							
P.2.1	150 (130–200)	120 (100–160)	0,90–1,20	1,50–2,00	1,50–2,00							
P.2.2	150 (130–200)	120 (100–160)	0,90–1,20	1,50–2,00	1,50–2,00							
P.2.3	150 (130–200)	120 (100–160)	0,90–1,20	1,50–2,00	1,50–2,00							
P.2.4	150 (130–200)	120 (100–160)	0,90–1,20	1,50–2,00	1,50–2,00	150 (130–200)	120 (100–160)	0,90–1,20	1,50–2,00	1,50–2,00		
P.3.1						30 (25–50)	30 (25–40)	0,70–0,90	1,20–1,60	1,20–1,60		
P.3.2						30 (25–50)	30 (25–40)	0,70–0,90	1,20–1,60	1,20–1,60		
P.3.3						30 (25–50)	30 (25–40)	0,70–0,90	1,20–1,60	1,20–1,60		
P.4.1						45 (35–60)	40 (35–50)	0,70–0,90	1,20–1,60	1,20–1,60		
P.4.2						45 (35–60)	40 (35–50)	0,70–0,90	1,20–1,60	1,20–1,60		
M.1.1						45 (35–60)	40 (35–50)	0,70–0,90	1,20–1,60	1,20–1,60		
M.2.1						30 (25–50)	30 (25–40)	0,70–0,90	1,20–1,60	1,20–1,60		
M.3.1						30 (25–50)	30 (25–40)	0,70–0,90	1,20–1,60	1,20–1,60		
K.1.1	200 (180–250)	160 (140–200)	1,00–1,40	1,30–1,90	1,30–1,90							
K.1.2	200 (180–250)	160 (140–200)	1,00–1,40	1,30–1,90	1,30–1,90							
K.2.1	225 (200–300)	180 (160–240)	1,00–1,40	1,30–1,90	1,30–1,90							
K.2.2	120 (100–150)	100 (80–120)	0,90–1,20	1,20–1,60	1,20–1,60							
K.3.1	150 (130–250)	120 (100–200)	0,90–1,20	1,20–1,60	1,20–1,60							
K.3.2	120 (100–150)	100 (80–120)	0,90–1,20	1,20–1,60	1,20–1,60							
N.1.1												
N.1.2												
N.2.1												
N.2.2												
N.2.3												
N.3.1												
N.3.2												
N.3.3												
N.4.1												
S.1.1												
S.1.2												
S.2.1												
S.2.2												
S.2.3												
S.3.1												
S.3.2												
S.3.3												
H.1.1						40 (35–60)	40 (35–60)	0,40–0,80	0,60–1,00	0,60–1,00		
H.1.2						40 (35–60)	40 (35–60)	0,40–0,80	0,60–1,00	0,60–1,00		
H.1.3						30 (25–50)	30 (25–50)	0,40–0,80	0,60–1,00	0,60–1,00		
H.1.4												
H.2.1						40 (35–60)	40 (35–60)	0,40–0,80	0,60–1,00	0,60–1,00		
H.3.1						40 (35–60)	40 (35–60)	0,40–0,80	0,60–1,00	0,60–1,00		
O.1.1												
O.1.2												
O.2.1												
O.2.2												
O.3.1												

4

 The cutting data depend extremely on the external conditions, the material and machine type. The indicated values are possible values which have to be increased or reduced, inside the bracket, according to the application conditions.

Cutting data standard values for REAMAX

Index	40 505 ...					40 570 ...					
	640.71 – ASG3000 / HM-TiN					640.27 – ASG0706 / HM-DBC					
	Nominal Ø in mm ▶		12–21,999	22–32,000	32,001–40	Nominal Ø in mm ▶		12–21,999	22–32,000	32,001–40	
	Reaming allowance Ø ▶		0,10–0,30	0,20–0,40	0,20–0,40	Reaming allowance Ø ▶		0,10–0,30	0,20–0,40	0,20–0,40	
	Number of flutes ▶		6	8	8	Number of flutes ▶		6	8	8	
3xD		5xD		f (mm/rev)		3xD		5xD		f (mm/rev)	
v _c (m/min)		f (mm/rev)		f (mm/rev)		v _c (m/min)		f (mm/rev)		f (mm/rev)	
P.1.1	100 (80–140)	80 (60–120)	0,90–1,20	1,50–2,00	1,50–2,00						
P.1.2	100 (80–140)	80 (60–120)	0,90–1,20	1,50–2,00	1,50–2,00						
P.1.3	100 (80–140)	80 (60–120)	0,90–1,20	1,50–2,00	1,50–2,00						
P.1.4	100 (80–140)	80 (60–120)	0,90–1,20	1,50–2,00	1,50–2,00						
P.1.5	100 (80–140)	80 (60–120)	0,90–1,20	1,50–2,00	1,50–2,00						
P.2.1	100 (80–140)	80 (60–120)	0,90–1,20	1,50–2,00	1,50–2,00						
P.2.2	100 (80–140)	80 (60–120)	0,90–1,20	1,50–2,00	1,50–2,00						
P.2.3	100 (80–140)	80 (60–120)	0,90–1,20	1,50–2,00	1,50–2,00						
P.2.4	100 (80–140)	80 (60–120)	0,90–1,20	1,50–2,00	1,50–2,00						
P.3.1											
P.3.2											
P.3.3											
P.4.1											
P.4.2											
M.1.1											
M.2.1											
M.3.1											
K.1.1	80 (60–130)	80 (60–120)	1,00–1,40	1,80–2,40	1,80–2,40						
K.1.2	80 (60–130)	80 (60–120)	1,00–1,40	1,80–2,40	1,80–2,40						
K.2.1											
K.2.2											
K.3.1											
K.3.2											
N.1.1						150 (130–300)	150 (130–200)	1,00–1,40	1,70–2,40	1,70–2,40	
N.1.2						200 (180–300)	150 (130–200)	1,00–1,40	1,70–2,40	1,70–2,40	
N.2.1						200 (180–300)	150 (130–200)	1,00–1,40	1,70–2,40	1,70–2,40	
N.2.2						200 (180–300)	150 (130–200)	1,00–1,40	1,70–2,40	1,70–2,40	
N.2.3											
N.3.1	120 (100–200)	120 (100–150)	1,00–1,40	1,70–2,40	1,70–2,40						
N.3.2	120 (100–200)	120 (100–150)	1,00–1,40	1,70–2,40	1,70–2,40						
N.3.3	80 (60–150)	80 (60–120)	0,80–1,20	1,40–2,00	1,40–2,00						
N.4.1											
S.1.1											
S.1.2											
S.2.1											
S.2.2											
S.2.3											
S.3.1											
S.3.2											
S.3.3											
H.1.1											
H.1.2											
H.1.3											
H.1.4											
H.2.1											
H.3.1											
O.1.1											
O.1.2											
O.2.1											
O.2.2											
O.3.1						250 (220–270)	250 (220–270)	1,00–1,40	1,70–2,40	1,70–2,40	



The cutting data depend extremely on the external conditions, the material and machine type. The indicated values are possible values which have to be increased or reduced, inside the bracket, according to the application conditions.

Cutting data standard values for REAMAX

Index	40 525 ...					40 536 ...				
	640.93 – ASG3000 / DST					640.93 – ASG4000 / DST				
	Nominal Ø in mm ▶		12–21,999	22–32,000	32,001–40	Nominal Ø in mm ▶		12–21,999	22–32,000	32,001–40
	Reaming allowance Ø ▶		0,10–0,30	0,20–0,40	0,20–0,40	Reaming allowance Ø ▶		0,10–0,30	0,20–0,40	0,20–0,40
	Number of flutes ▶		6	8	8	Number of flutes ▶		6	8	8
3xD		5xD		f (mm/rev)	3xD		5xD		f (mm/rev)	
v _c (m/min)		v _c (m/min)			v _c (m/min)		v _c (m/min)			
P.1.1	150 (130–200)	120 (100–160)	0,90–1,20	1,50–2,00	1,50–2,00	150 (130–200)	120 (100–160)	1,10–1,40	1,80–2,40	1,80–2,40
P.1.2	150 (130–200)	120 (100–160)	0,90–1,20	1,50–2,00	1,50–2,00	150 (130–200)	120 (100–160)	1,10–1,40	1,80–2,40	1,80–2,40
P.1.3	150 (130–200)	120 (100–160)	0,90–1,20	1,50–2,00	1,50–2,00	150 (130–200)	120 (100–160)	1,10–1,40	1,80–2,40	1,80–2,40
P.1.4	150 (130–200)	120 (100–160)	0,90–1,20	1,50–2,00	1,50–2,00	150 (130–200)	120 (100–160)	1,10–1,40	1,80–2,40	1,80–2,40
P.1.5	150 (130–200)	120 (100–160)	0,90–1,20	1,50–2,00	1,50–2,00	150 (130–200)	120 (100–160)	1,10–1,40	1,80–2,40	1,80–2,40
P.2.1	150 (130–200)	120 (100–160)	0,90–1,20	1,50–2,00	1,50–2,00	150 (130–200)	120 (100–160)	1,10–1,40	1,80–2,40	1,80–2,40
P.2.2	150 (130–200)	120 (100–160)	0,90–1,20	1,50–2,00	1,50–2,00	150 (130–200)	120 (100–160)	1,10–1,40	1,80–2,40	1,80–2,40
P.2.3	150 (130–200)	120 (100–160)	0,90–1,20	1,50–2,00	1,50–2,00	150 (130–200)	120 (100–160)	1,10–1,40	1,80–2,40	1,80–2,40
P.2.4										
P.3.1										
P.3.2										
P.3.3										
P.4.1										
P.4.2										
M.1.1										
M.2.1										
M.3.1										
K.1.1										
K.1.2										
K.2.1	175 (150–300)	150 (130–180)	1,00–1,40	1,80–2,40	1,80–2,40	175 (150–300)	150 (130–180)	1,20–1,60	1,50–2,00	2,00–2,70
K.2.2	150 (130–250)	120 (100–160)	1,00–1,40	1,80–2,40	1,80–2,40	120 (100–180)	120 (100–150)	1,20–1,60	1,50–2,00	2,00–2,70
K.3.1	150 (130–250)	120 (100–160)	1,00–1,40	1,80–2,40	1,80–2,40					
K.3.2	120 (100–180)	120 (100–150)	0,90–1,20	1,50–2,00	1,50–2,00	120 (100–180)	120 (100–150)	1,00–1,30	1,20–1,70	1,70–2,30
N.1.1										
N.1.2										
N.2.1										
N.2.2										
N.2.3										
N.3.1	150 (130–300)	150 (130–200)	1,00–1,40	1,70–2,40	1,70–2,40					
N.3.2	150 (130–300)	150 (130–200)	1,00–1,40	1,70–2,40	1,70–2,40					
N.3.3										
N.4.1										
S.1.1										
S.1.2										
S.2.1										
S.2.2										
S.2.3										
S.3.1										
S.3.2										
S.3.3										
H.1.1										
H.1.2										
H.1.3										
H.1.4										
H.2.1										
H.3.1										
O.1.1										
O.1.2										
O.2.1										
O.2.2										
O.3.1										

4

 The cutting data depend extremely on the external conditions, the material and machine type. The indicated values are possible values which have to be increased or reduced, inside the bracket, according to the application conditions.

Cutting data for MultiChange exchange head reamers

Index	40 210 ..., 40 211 ...				40 220 ..., 40 221 ...				40 240 ..., 40 241 ...			
	CWC10				TiAlN				K10			
	Nominal Ø in mm▶	8,0–12,59	12,6–29,99	30,0–32,00	Nominal Ø in mm▶	8,0–12,59	12,6–29,99	30,0–32,00	Nominal Ø in mm▶	8,0–12,59	12,6–29,99	30,0–32,00
	Reaming allowance Ø▶	0,15–0,3	0,2–0,4	0,2–0,4	Reaming allowance Ø▶	0,15–0,3	0,15–0,3	0,15–0,3	Reaming allowance Ø▶	0,15–0,5	0,15–0,5	0,15–0,5
	Number of flutes▶	4 / 6	6	8	Number of flutes▶	4 / 6	6	8	Number of flutes▶	4 / 6	6	8
	v_c (m/min)	f (mm/rev)			v_c (m/min)	f (mm/rev)			v_c (m/min)	f (mm/rev)		
P.1.1	140	0,6	0,8	1,0								
P.1.2	140	0,6	0,8	1,0								
P.1.3	90	0,6	0,8	1,0								
P.1.4	90	0,6	0,8	1,0								
P.1.5	90	0,6	0,8	1,0								
P.2.1	140	0,6	0,8	1,0								
P.2.2	140	0,6	0,8	1,0								
P.2.3	90	0,6	0,8	1,0								
P.2.4	90	0,6	0,8	1,0								
P.3.1	120	0,6	0,8	1,0								
P.3.2	90	0,6	0,8	1,0								
P.3.3	90	0,6	0,8	1,0								
P.4.1					40	0,3	0,4	0,5				
P.4.2					40	0,3	0,4	0,5				
M.1.1					40	0,3	0,4	0,5				
M.2.1					40	0,3	0,4	0,5				
M.3.1					30	0,3	0,4	0,5				
K.1.1												
K.1.2												
K.2.1	120	0,7	1,2	1,6								
K.2.2	90	0,7	1,2	1,6								
K.3.1	90	0,7	1,2	1,6								
K.3.2	90	0,7	1,2	1,6								
N.1.1									30	0,4	0,5	0,6
N.1.2									30	0,4	0,5	0,6
N.2.1									30	0,4	0,5	0,6
N.2.2									30	0,4	0,5	0,6
N.2.3									30	0,4	0,5	0,6
N.3.1									30	0,4	0,5	0,6
N.3.2									30	0,4	0,5	0,6
N.3.3									30	0,4	0,5	0,6
N.4.1												
S.1.1												
S.1.2												
S.2.1												
S.2.2												
S.2.3												
S.3.1												
S.3.2												
S.3.3												
H.1.1												
H.1.2												
H.1.3												
H.1.4												
H.2.1												
H.3.1												
O.1.1												
O.1.2												
O.2.1												
O.2.2												
O.3.1												

 The cutting data is strongly influenced by external conditions, such as the stability of the tool and workpiece clamping, material and type of machine. The specified values represent guideline cutting data that can be adjusted by approx. ±20% according to the usage conditions.

Cutting data standard values for Monomax

Index	40 656 ..., 40 666 ..., 40 657 ..., 40 665 ...						40 652 ..., 40 653 ...								
	56J.65, 56R.65, 56H.65, 56Q.65 – ASG3000 / HM-DBG-P						56J.65, 56R.65 – ASG0106 / HM-DBG-P								
	Nominal Ø in mm ▶		5,6–8,899	8,9–12,00	12,01–22,00	22,01–25,899	Nominal Ø in mm ▶		5,6–8,899	8,9–12,00	12,01–22,00	22,01–25,899			
	Reaming allowance Ø ▶		0,10–0,20	0,10–0,30	0,20–0,30	0,20–0,40	Reaming allowance Ø ▶		0,10–0,20	0,10–0,30	0,20–0,30	0,20–0,40			
	Number of flutes ▶		4	6	6	6	Number of flutes ▶		4	6	6	6			
3xD		5xD		f (mm/rev)				3xD		5xD		f (mm/rev)			
v _c (m/min)		v _c (m/min)		f (mm/rev)				v _c (m/min)		v _c (m/min)		f (mm/rev)			
P.1.1	150 (130–200)	120 (100–160)	0,30–0,50	0,50–0,70	0,70–1,00	0,90–1,30									
P.1.2	150 (130–200)	120 (100–160)	0,30–0,50	0,50–0,70	0,70–1,00	0,90–1,30									
P.1.3	150 (130–200)	120 (100–160)	0,30–0,50	0,50–0,70	0,70–1,00	0,90–1,30									
P.1.4	150 (130–200)	120 (100–160)	0,30–0,50	0,50–0,70	0,70–1,00	0,90–1,30									
P.1.5	150 (130–200)	120 (100–160)	0,30–0,50	0,50–0,70	0,70–1,00	0,90–1,30									
P.2.1	150 (130–200)	120 (100–160)	0,30–0,50	0,50–0,70	0,70–1,00	0,90–1,30									
P.2.2	150 (130–200)	120 (100–160)	0,30–0,50	0,50–0,70	0,70–1,00	0,90–1,30									
P.2.3	150 (130–200)	120 (100–160)	0,30–0,50	0,50–0,70	0,70–1,00	0,90–1,30									
P.2.4	60 (50–100)	60 (50–100)	0,20–0,30	0,40–0,50	0,50–0,70	0,60–0,90	60 (50–100)	60 (50–100)	0,20–0,30	0,40–0,50	0,50–0,70	0,60–0,90			
P.3.1							40 (35–60)	40 (35–60)	0,20–0,30	0,40–0,50	0,50–0,70	0,60–0,90			
P.3.2							40 (35–60)	40 (35–60)	0,20–0,30	0,40–0,50	0,50–0,70	0,60–0,90			
P.3.3							30 (25–50)	30 (25–40)	0,30–0,40	0,40–0,60	0,60–0,80	0,70–1,00			
P.4.1							45 (35–60)	40 (35–50)	0,30–0,40	0,40–0,60	0,60–0,80	0,70–1,00			
P.4.2							45 (35–60)	40 (35–50)	0,30–0,40	0,40–0,60	0,60–0,80	0,70–1,00			
M.1.1							30 (25–50)	30 (25–40)	0,30–0,40	0,40–0,60	0,60–0,80	0,70–1,00			
M.2.1							30 (25–50)	30 (25–40)	0,30–0,40	0,40–0,60	0,60–0,80	0,70–1,00			
M.3.1							30 (25–50)	30 (25–40)	0,30–0,40	0,40–0,60	0,60–0,80	0,70–1,00			
K.1.1	150 (130–220)	120 (100–150)	0,40–0,60	0,70–0,90	0,90–1,20	1,10–1,50									
K.1.2	150 (130–220)	120 (100–150)	0,40–0,60	0,70–0,90	0,90–1,20	1,10–1,50									
K.2.1	175 (150–300)	150 (130–180)	0,40–0,60	0,70–0,90	0,90–1,20	1,10–1,50									
K.2.2	120 (100–180)	120 (100–150)	0,30–0,50	0,50–0,70	0,70–1,00	0,90–1,30									
K.3.1	150 (130–250)	120 (100–160)	0,40–0,60	0,70–0,90	0,90–1,20	1,10–1,50									
K.3.2	120 (100–180)	120 (100–150)	0,30–0,50	0,50–0,70	0,70–1,00	0,90–1,30									
N.1.1															
N.1.2															
N.2.1															
N.2.2															
N.2.3															
N.3.1															
N.3.2															
N.3.3															
N.4.1															
S.1.1															
S.1.2															
S.2.1															
S.2.2															
S.2.3															
S.3.1															
S.3.2															
S.3.3															
H.1.1															
H.1.2															
H.1.3															
H.1.4															
H.2.1															
H.3.1															
O.1.1															
O.1.2															
O.2.1															
O.2.2															
O.3.1															

4

 The cutting data depend extremely on the external conditions, the material and machine type. The indicated values are possible values which have to be increased or reduced, inside the bracket, according to the application conditions.

Cutting data standard values for Monomax

Index	40 644 ..., 40 645 ...						40 605 ..., 40 606 ...												
	56H.65, 56Q.65 – ASG0106 / HM-DBG-P						56J.71, 56R.71 – ASG3000 / HM-TiN												
	Nominal Ø in mm ▶		5,6–8,899	8,9–12,00	12,01–22,00	22,01–25,899		Nominal Ø in mm ▶		5,6–8,899	8,9–12,00	12,01–22,00	22,01–25,899						
	Reaming allowance Ø ▶		0,10–0,20	0,10–0,30	0,20–0,30	0,20–0,40		Reaming allowance Ø ▶		0,10–0,20	0,10–0,30	0,20–0,30	0,20–0,40						
	Number of flutes ▶		4	6	6	6		Number of flutes ▶		4	6	6	6						
3xD		5xD		f (mm/rev)						3xD		5xD		f (mm/rev)					
v _c (m/min)		v _c (m/min)		f (mm/rev)						v _c (m/min)		v _c (m/min)		f (mm/rev)					
P.1.1										100 (80–140)	80 (60–120)	0,30–0,50	0,50–0,70	0,70–1,00	0,90–1,30				
P.1.2										100 (80–140)	80 (60–120)	0,30–0,50	0,50–0,70	0,70–1,00	0,90–1,30				
P.1.3										100 (80–140)	80 (60–120)	0,30–0,50	0,50–0,70	0,70–1,00	0,90–1,30				
P.1.4										100 (80–140)	80 (60–120)	0,30–0,50	0,50–0,70	0,70–1,00	0,90–1,30				
P.1.5										100 (80–140)	80 (60–120)	0,30–0,50	0,50–0,70	0,70–1,00	0,90–1,30				
P.2.1										100 (80–140)	80 (60–120)	0,30–0,50	0,50–0,70	0,70–1,00	0,90–1,30				
P.2.2										100 (80–140)	80 (60–120)	0,30–0,50	0,50–0,70	0,70–1,00	0,90–1,30				
P.2.3										100 (80–140)	80 (60–120)	0,30–0,50	0,50–0,70	0,70–1,00	0,90–1,30				
P.2.4										100 (80–140)	80 (60–120)	0,30–0,50	0,50–0,70	0,70–1,00	0,90–1,30				
P.3.1	30 (25–50)	30 (25–40)	0,30–0,40	0,40–0,60	0,60–0,80	0,70–1,00													
P.3.2	30 (25–50)	30 (25–40)	0,30–0,40	0,40–0,60	0,60–0,80	0,70–1,00													
P.3.3	30 (25–50)	30 (25–40)	0,30–0,40	0,40–0,60	0,60–0,80	0,70–1,00													
P.4.1	45 (35–60)	40 (35–50)	0,30–0,40	0,40–0,60	0,60–0,80	0,70–1,00													
P.4.2	45 (35–60)	40 (35–50)	0,30–0,40	0,40–0,60	0,60–0,80	0,70–1,00													
M.1.1	45 (35–60)	40 (35–50)	0,30–0,40	0,40–0,60	0,60–0,80	0,70–1,00													
M.2.1	45 (35–60)	40 (35–50)	0,30–0,40	0,40–0,60	0,60–0,80	0,70–1,00													
M.3.1	30 (25–50)	30 (25–40)	0,30–0,40	0,40–0,60	0,60–0,80	0,70–1,00													
K.1.1								80 (60–130)	80 (60–120)	0,40–0,60	0,70–0,90	0,90–1,20	1,10–1,50						
K.1.2								80 (60–130)	80 (60–120)	0,40–0,60	0,70–0,90	0,90–1,20	1,10–1,50						
K.2.1																			
K.2.2																			
K.3.1																			
K.3.2																			
N.1.1																			
N.1.2																			
N.2.1																			
N.2.2																			
N.2.3																			
N.3.1								120 (–200)	120 (–200)	0,40–0,60	0,60–0,90	0,80–1,20	1,10–1,50						
N.3.2								120 (–200)	120 (–200)	0,40–0,60	0,60–0,90	0,80–1,20	1,10–1,50						
N.3.3								80 (–150)	80 (–120)	0,40–0,60	0,60–0,90	0,80–1,20	1,10–1,50						
N.4.1																			
S.1.1																			
S.1.2																			
S.2.1																			
S.2.2																			
S.2.3																			
S.3.1																			
S.3.2																			
S.3.3																			
H.1.1																			
H.1.2																			
H.1.3																			
H.1.4																			
H.2.1																			
H.3.1																			
O.1.1																			
O.1.2																			
O.2.1																			
O.2.2																			
O.3.1																			

 The cutting data depend extremely on the external conditions, the material and machine type. The indicated values are possible values which have to be increased or reduced, inside the bracket, according to the application conditions.

Cutting data standard values for Monomax

Index	40 625 ..., 40 626 ...						40 635 ..., 40 636 ...					
	56J.93, 56R.93 – ASG3000 / DST						56J.93, 56R.93 – ASG4000 / DST					
	Nominal Ø in mm ▶		5,6–8,899	8,9–12,00	12,01–22,00	22,01–25,899	Nominal Ø in mm ▶		5,6–8,899	8,9–12,00	12,01–22,00	22,01–25,899
	Reaming allowance Ø ▶		0,10–0,20	0,10–0,30	0,20–0,30	0,20–0,40	Reaming allowance Ø ▶		0,10–0,20	0,10–0,30	0,20–0,30	0,20–0,40
	Number of flutes ▶		4	6	6	6	Number of flutes ▶		4	6	6	6
	3xD		5xD		f (mm/rev)		3xD		5xD		f (mm/rev)	
v _c (m/min)		f (mm/rev)		v _c (m/min)		f (mm/rev)		v _c (m/min)		f (mm/rev)		
P.1.1	150 (130–200)	120 (100–160)	0,30–0,50	0,50–0,70	0,70–1,00	0,90–1,30	150 (130–200)	120 (100–160)	0,40–0,60	0,70–0,90	0,90–1,20	1,20–1,50
P.1.2	150 (130–200)	120 (100–160)	0,30–0,50	0,50–0,70	0,70–1,00	0,90–1,30	150 (130–200)	120 (100–160)	0,40–0,60	0,70–0,90	0,90–1,20	1,20–1,50
P.1.3	150 (130–200)	120 (100–160)	0,30–0,50	0,50–0,70	0,70–1,00	0,90–1,30	150 (130–200)	120 (100–160)	0,40–0,60	0,70–0,90	0,90–1,20	1,20–1,50
P.1.4	150 (130–200)	120 (100–160)	0,30–0,50	0,50–0,70	0,70–1,00	0,90–1,30	150 (130–200)	120 (100–160)	0,40–0,60	0,70–0,90	0,90–1,20	1,20–1,50
P.1.5	150 (130–200)	120 (100–160)	0,30–0,50	0,50–0,70	0,70–1,00	0,90–1,30	150 (130–200)	120 (100–160)	0,40–0,60	0,70–0,90	0,90–1,20	1,20–1,50
P.2.1	150 (130–200)	120 (100–160)	0,30–0,50	0,50–0,70	0,70–1,00	0,90–1,30	150 (130–200)	120 (100–160)	0,40–0,60	0,70–0,90	0,90–1,20	1,20–1,50
P.2.2	150 (130–200)	120 (100–160)	0,30–0,50	0,50–0,70	0,70–1,00	0,90–1,30	150 (130–200)	120 (100–160)	0,40–0,60	0,70–0,90	0,90–1,20	1,20–1,50
P.2.3	150 (130–200)	120 (100–160)	0,30–0,50	0,50–0,70	0,70–1,00	0,90–1,30	150 (130–200)	120 (100–160)	0,40–0,60	0,70–0,90	0,90–1,20	1,20–1,50
P.2.4												
P.3.1												
P.3.2												
P.3.3												
P.4.1												
P.4.2												
M.1.1												
M.2.1												
M.3.1												
K.1.1												
K.1.2												
K.2.1	175 (150–300)	150 (130–180)	0,40–0,60	0,70–0,90	0,90–1,20	1,10–1,50	175 (150–300)	150 (130–180)	0,40–0,60	0,70–0,90	0,90–1,20	1,10–1,50
K.2.2	120 (100–150)	100 (80–120)	0,30–0,50	0,50–0,70	0,70–1,00	0,90–1,30	120 (100–180)	120 (100–150)	0,30–0,50	0,50–0,70	0,70–1,00	0,90–1,30
K.3.1	150 (130–250)	120 (100–200)	0,40–0,60	0,70–0,90	0,90–1,20	1,10–1,50	120 (100–180)	120 (100–150)	0,30–0,50	0,50–0,70	0,70–1,00	0,90–1,30
K.3.2	120 (100–180)	120 (100–150)	0,30–0,50	0,50–0,70	0,70–1,00	0,90–1,30	120 (100–180)	120 (100–150)	0,30–0,50	0,50–0,70	0,70–1,00	0,90–1,30
N.1.1												
N.1.2												
N.2.1												
N.2.2												
N.2.3												
N.3.1	150 (130–300)	150 (130–200)	0,40–0,60	0,60–0,90	0,80–1,20	1,10–1,50						
N.3.2	150 (130–300)	150 (130–200)	0,40–0,60	0,60–0,90	0,80–1,20	1,10–1,50						
N.3.3												
N.4.1												
S.1.1												
S.1.2												
S.2.1												
S.2.2												
S.2.3												
S.3.1												
S.3.2												
S.3.3												
H.1.1												
H.1.2												
H.1.3												
H.1.4												
H.2.1												
H.3.1												
O.1.1												
O.1.2												
O.2.1												
O.2.2												
O.3.1												

4

 The cutting data depend extremely on the external conditions, the material and machine type. The indicated values are possible values which have to be increased or reduced, inside the bracket, according to the application conditions.

Cutting data standard values for Monomax

Index	40 648 ..., 40 649 ...						40 640 ..., 40 641 ...											
	56J.17, 56R.17 – ASG0706 / DBC						56H.17, 56Q.17 – ASG0706 / DBC											
	Nominal Ø in mm ▶		5,6–8,899	8,9–12,00	12,01–22,00	22,01–25,899		Nominal Ø in mm ▶		5,6–8,899	8,9–12,00	12,01–22,00	22,01–25,899					
	Reaming allowance Ø ▶		0,10–0,20	0,10–0,30	0,20–0,30	0,20–0,40		Reaming allowance Ø ▶		0,10–0,20	0,10–0,30	0,20–0,30	0,20–0,40					
	Number of flutes ▶		4	6	6	6		Number of flutes ▶		4	6	6	6					
3xD		5xD		f (mm/rev)				3xD		5xD		f (mm/rev)						
v _c (m/min)		v _c (m/min)		f (mm/rev)				v _c (m/min)		v _c (m/min)		f (mm/rev)						
P.1.1																		
P.1.2																		
P.1.3																		
P.1.4																		
P.1.5																		
P.2.1																		
P.2.2																		
P.2.3																		
P.2.4																		
P.3.1																		
P.3.2																		
P.3.3																		
P.4.1																		
P.4.2																		
M.1.1																		
M.2.1																		
M.3.1																		
K.1.1																		
K.1.2																		
K.2.1																		
K.2.2																		
K.3.1																		
K.3.2																		
N.1.1	150 (130–300)	150 (130–200)	0,40–0,60	0,40–0,60	0,80–1,20	0,80–1,50	150 (130–300)	150 (130–200)	0,40–0,60	0,40–0,60	0,80–1,20	0,80–1,50	150 (130–300)	150 (130–200)	0,40–0,60	0,40–0,60	0,80–1,20	0,80–1,50
N.1.2	150 (130–300)	150 (130–200)	0,40–0,60	0,40–0,60	0,80–1,20	0,80–1,50	150 (130–300)	150 (130–200)	0,40–0,60	0,40–0,60	0,80–1,20	0,80–1,50	150 (130–300)	150 (130–200)	0,40–0,60	0,40–0,60	0,80–1,20	0,80–1,50
N.2.1	200 (180–300)	150 (130–200)	0,40–0,60	0,40–0,60	0,80–1,20	0,80–1,50	200 (180–300)	150 (130–200)	0,40–0,60	0,40–0,60	0,80–1,20	0,80–1,50	200 (180–300)	150 (130–200)	0,40–0,60	0,40–0,60	0,80–1,20	0,80–1,50
N.2.2	200 (180–300)	150 (130–200)	0,40–0,60	0,40–0,60	0,80–1,20	0,80–1,50	200 (180–300)	150 (130–200)	0,40–0,60	0,40–0,60	0,80–1,20	0,80–1,50	200 (180–300)	150 (130–200)	0,40–0,60	0,40–0,60	0,80–1,20	0,80–1,50
N.2.3	200 (180–300)	150 (130–200)	0,40–0,60	0,40–0,60	0,80–1,20	0,80–1,50	200 (180–300)	150 (130–200)	0,40–0,60	0,40–0,60	0,80–1,20	0,80–1,50	200 (180–300)	150 (130–200)	0,40–0,60	0,40–0,60	0,80–1,20	0,80–1,50
N.3.1																		
N.3.2																		
N.3.3																		
N.4.1																		
S.1.1																		
S.1.2																		
S.2.1																		
S.2.2																		
S.2.3																		
S.3.1																		
S.3.2																		
S.3.3																		
H.1.1																		
H.1.2																		
H.1.3																		
H.1.4																		
H.2.1																		
H.3.1																		
O.1.1																		
O.1.2																		
O.2.1																		
O.2.2																		
O.3.1	250 (220–270)	250 (220–270)	0,40–0,60	0,40–0,60	0,80–1,20	0,80–1,50	250 (220–270)	250 (220–270)	0,40–0,60	0,40–0,60	0,80–1,20	0,80–1,50	250 (220–270)	250 (220–270)	0,40–0,60	0,40–0,60	0,80–1,20	0,80–1,50

 The cutting data depend extremely on the external conditions, the material and machine type. The indicated values are possible values which have to be increased or reduced, inside the bracket, according to the application conditions.

Cutting data standard values for Fullmax, long

Index	40 477 ..., 40 478 ...						
	Type K						
	Ø range (mm) ▶	Ø 2,97 – 4,05	Ø 4,06 – 6,05	Ø 6,06 – 7,55	Ø 7,56 – 12,05	Ø 12,06 – 16,05	Ø 16,06 – 20,05
	Reaming allowance Ø ▶	0,10–0,20	0,10–0,20	0,20	0,20	0,20–0,30	0,30
	Number of flutes ▶	6	6	8	8	8	8
v _c (m/min)		f (mm/rev)					
K.1.1	200 (180–250)	0,80–1,00	0,90–1,20	1,50–1,90	1,50–1,90	1,80–2,30	2,20–2,60
K.1.2	200 (180–250)	0,80–1,00	0,90–1,20	1,50–1,90	1,50–1,90	1,80–2,30	2,20–2,60
K.2.1	225 (200–300)	0,80–1,00	0,90–1,20	1,50–1,90	1,50–1,90	1,80–2,30	2,20–2,60
K.2.2	120 (100–150)	0,60–0,90	0,70–1,00	1,20–1,60	1,20–1,60	1,50–1,90	1,80–2,20
K.3.1	225 (200–300)	0,80–1,00	0,90–1,20	1,50–1,90	1,50–1,90	1,80–2,30	2,20–2,60
K.3.2	120 (100–150)	0,60–0,90	0,70–1,00	1,20–1,60	1,20–1,60	1,50–1,90	1,80–2,20

Index	40 401 ..., 40 402 ..., 40 403 ..., 40 404 ...						
	Type VA						
	Ø range (mm) ▶	Ø 2,97 – 4,05	Ø 4,06 – 6,05	Ø 6,06 – 7,55	Ø 7,56 – 12,05	Ø 12,06 – 16,05	Ø 16,06 – 20,05
	Reaming allowance Ø ▶	0,10–0,20	0,10–0,20	0,20	0,20	0,20–0,30	0,30
	Number of flutes ▶	4	4	6	6	6	6
v _c (m/min)		f (mm/rev)					
P.3.1	20 (15–40)	0,32–0,50	0,32–0,50	0,48–0,60	0,48–0,60	0,60–0,72	0,60–0,72
P.3.2	20 (15–40)	0,32–0,50	0,32–0,50	0,48–0,60	0,48–0,60	0,60–0,72	0,60–0,72
P.3.3	20 (15–40)	0,32–0,50	0,32–0,50	0,48–0,60	0,48–0,60	0,60–0,72	0,60–0,72
P.4.1	20 (15–40)	0,32–0,50	0,32–0,50	0,48–0,60	0,48–0,60	0,60–0,72	0,60–0,72
P.4.2	20 (15–40)	0,32–0,50	0,32–0,50	0,48–0,60	0,48–0,60	0,60–0,72	0,60–0,72
M.1.1	20 (15–40)	0,32–0,50	0,32–0,50	0,48–0,60	0,48–0,60	0,60–0,72	0,60–0,72
M.2.1	15 (10–30)	0,32–0,50	0,32–0,50	0,48–0,60	0,48–0,60	0,60–0,72	0,60–0,72
M.3.1	15 (10–30)	0,32–0,50	0,32–0,50	0,48–0,60	0,48–0,60	0,60–0,72	0,60–0,72

Index	40 471 ..., 40 472 ..., 40 473 ..., 40 474 ...						
	Type ALU						
	Ø range (mm) ▶	Ø 2,97 – 4,05	Ø 4,06 – 6,05	Ø 6,06 – 7,55	Ø 7,56 – 12,05	Ø 12,06 – 16,05	Ø 16,06 – 20,05
	Reaming allowance Ø ▶	0,10–0,20	0,10–0,20	0,20	0,20	0,20–0,30	0,30
	Number of flutes ▶	4	4	6	6	6	6
v _c (m/min)		f (mm/rev)					
N.1.1	200 (180–300)	0,50–0,60	0,60–0,90	1,10–1,60	1,20–1,60	1,20–1,80	1,20–1,80
N.1.2	200 (180–300)	0,50–0,60	0,60–0,90	1,10–1,60	1,20–1,60	1,20–1,80	1,20–1,80
N.2.1	200 (180–250)	0,50–0,70	0,70–1,00	1,20–1,70	1,30–1,70	1,30–2,00	1,30–2,00
N.2.2	200 (180–300)	0,50–0,70	0,70–1,00	1,20–1,70	1,30–1,70	1,30–2,00	1,30–2,00
N.2.3	200 (180–250)	0,50–0,70	0,70–1,00	1,20–1,70	1,30–1,70	1,30–2,00	1,30–2,00
O.3.1	250 (220–270)	0,50–0,70	0,70–1,00	1,20–1,70	1,30–1,70	1,30–2,00	1,30–2,00

Index	40 475 ..., 40 476 ...						
	Type H						
	Ø range (mm) ▶	Ø 2,97 – 4,05	Ø 4,06 – 6,05	Ø 6,06 – 7,55	Ø 7,56 – 12,05	Ø 12,06 – 16,05	Ø 16,06 – 20,05
	Reaming allowance Ø ▶	0,10–0,20	0,10–0,20	0,20	0,20	0,20	0,20
	Number of flutes ▶	4	4	6	6	6	6
v _c (m/min)		f (mm/rev)					
H.1.1	40 (35–60)	0,20–0,30	0,20–0,30	0,40–0,60	0,50–0,60	0,50–0,70	0,60–0,80
H.1.2	30 (25–50)	0,20–0,30	0,20–0,30	0,40–0,60	0,50–0,60	0,50–0,70	0,60–0,80
H.1.3	30 (25–50)	0,20–0,30	0,20–0,30	0,40–0,60	0,50–0,60	0,50–0,70	0,60–0,80
H.1.4	30 (25–50)	0,20–0,30	0,20–0,30	0,40–0,60	0,50–0,60	0,50–0,70	0,60–0,80
H.2.1	40 (35–60)	0,20–0,30	0,20–0,30	0,40–0,60	0,50–0,60	0,50–0,70	0,60–0,80
H.3.1	40 (35–60)	0,20–0,30	0,20–0,30	0,40–0,60	0,50–0,60	0,50–0,70	0,60–0,80

* Wet machining recommended

 The cutting data depend extremely on the external conditions, the material and machine type. The indicated values are possible values which have to be increased or reduced, inside the bracket, according to the application conditions.

Cutting data standard values for solid carbide reamers – Type H

Index	40 435 ...								
	Ø 0,98 – 3,99			Ø 4,00 – 8,00		Ø 8,01 – 16,00		Ø 16,01 – 20,00	
	v_c (m/min)	f (mm/rev)	Reaming allowance \varnothing	f (mm/rev)	Reaming allowance \varnothing	f (mm/rev)	Reaming allowance \varnothing	f (mm/rev)	Reaming allowance \varnothing
P.1.1	16	0,10	0,20	0,20	0,20	0,238	0,30	0,275	0,30
P.1.2	13	0,08	0,20	0,16	0,20	0,195	0,30	0,23	0,30
P.1.3	12	0,075	0,20	0,15	0,20	0,175	0,30	0,20	0,30
P.1.4	12	0,075	0,20	0,15	0,20	0,175	0,30	0,20	0,30
P.1.5	19	0,08	0,20	0,16	0,20	0,195	0,30	0,23	0,30
P.2.1	15	0,08	0,20	0,16	0,20	0,195	0,30	0,23	0,30
P.2.2	14	0,08	0,20	0,16	0,20	0,195	0,30	0,23	0,30
P.2.3	13	0,08	0,20	0,16	0,20	0,195	0,30	0,23	0,30
P.2.4	12	0,075	0,20	0,15	0,20	0,175	0,30	0,20	0,30
P.3.1									
P.3.2	11	0,063	0,20	0,125	0,20	0,15	0,30	0,175	0,30
P.3.3	11	0,063	0,20	0,125	0,20	0,15	0,30	0,175	0,30
P.4.1	11	0,063	0,20	0,125	0,20	0,15	0,30	0,175	0,30
P.4.2	8	0,05	0,20	0,10	0,20	0,113	0,30	0,125	0,30
M.1.1									
M.2.1	9	0,063	0,10	0,125	0,10	0,15	0,20	0,175	0,20
M.3.1	9	0,063	0,10	0,125	0,10	0,15	0,20	0,175	0,20
K.1.1	17	0,125	0,20	0,25	0,20	0,325	0,30	0,40	0,30
K.1.2	14	0,113	0,20	0,225	0,20	0,275	0,30	0,325	0,30
K.2.1	17	0,113	0,20	0,225	0,20	0,275	0,30	0,325	0,30
K.2.2	14	0,10	0,20	0,20	0,20	0,238	0,30	0,275	0,30
K.3.1	17	0,113	0,20	0,225	0,20	0,275	0,30	0,325	0,30
K.3.2	14	0,10	0,20	0,20	0,20	0,238	0,30	0,275	0,30
N.1.1									
N.1.2									
N.2.1									
N.2.2									
N.2.3									
N.3.1									
N.3.2									
N.3.3									
N.4.1									
S.1.1									
S.1.2									
S.2.1									
S.2.2									
S.2.3									
S.3.1									
S.3.2									
S.3.3									
H.1.1	8	0,075	0,10	0,15	0,20	0,175	0,30	0,20	0,30
H.1.2	7	0,063	0,10	0,125	0,20	0,15	0,30	0,175	0,30
H.1.3	5	0,05	0,10	0,10	0,20	0,113	0,30	0,125	0,30
H.1.4									
H.2.1									
H.3.1									
O.1.1									
O.1.2									
O.2.1									
O.2.2									
O.3.1									

* Wet machining preferred/dry machining possible

 The cutting data is strongly influenced by external conditions, such as the stability of the tool and workpiece clamping, material and type of machine. The specified values represent guideline cutting data that can be adjusted by approx. $\pm 20\%$ according to the usage conditions.

Cutting data standard values for solid carbide reamers

Index	40 405 ..., 40 415 ...						
	uncoated	≤ Ø 4,80		Ø 4,81 – 8,00		Ø 8,01 – 12,00	
		v_c (m/min)	f (mm/rev)	Reaming allowance Ø	f (mm/rev)	Reaming allowance Ø	f (mm/rev)
P.1.1	15 (10–20)	0,1	0,05–0,1	0,15	0,1–0,15	0,175–0,2	0,1–0,2
P.1.2	15 (10–20)	0,1	0,05–0,1	0,15	0,1–0,15	0,175–0,2	0,1–0,2
P.1.3	15 (10–20)	0,1	0,05–0,1	0,15	0,1–0,15	0,175–0,2	0,1–0,2
P.1.4	15 (10–20)	0,1	0,05–0,1	0,15	0,1–0,15	0,175–0,2	0,1–0,2
P.1.5	15 (10–20)	0,1	0,05–0,1	0,15	0,1–0,15	0,175–0,2	0,1–0,2
P.2.1	15 (10–20)	0,1	0,05–0,1	0,15	0,1–0,15	0,175–0,2	0,1–0,2
P.2.2	15 (10–20)	0,1	0,05–0,1	0,15	0,1–0,15	0,175–0,2	0,1–0,2
P.2.3	15 (10–20)	0,1	0,05–0,1	0,15	0,1–0,15	0,175–0,2	0,1–0,2
P.2.4	15 (10–20)	0,1	0,05–0,1	0,15	0,1–0,15	0,175–0,2	0,1–0,2
P.3.1	15 (10–20)	0,1	0,05–0,1	0,15	0,1–0,15	0,175–0,2	0,1–0,2
P.3.2	15 (10–20)	0,1	0,05–0,1	0,15	0,1–0,15	0,175–0,2	0,1–0,2
P.3.3							
P.4.1							
P.4.2							
M.1.1							
M.2.1							
M.3.1							
K.1.1	15 (10–15)	0,1	0,05–0,1	0,2	0,1–0,15	0,25–0,3	0,1–0,2
K.1.2	15 (10–20)	0,1	0,05–0,1	0,2	0,1–0,15	0,25–0,3	0,1–0,2
K.2.1	15 (10–15)	0,1	0,05–0,1	0,2	0,1–0,15	0,25–0,3	0,1–0,2
K.2.2	10 (5–15)	0,1	0,05–0,1	0,2	0,1–0,15	0,25–0,3	0,1–0,2
K.3.1	15 (10–20)	0,1	0,05–0,1	0,2	0,1–0,15	0,25–0,3	0,1–0,2
K.3.2	10 (5–15)	0,1	0,05–0,1	0,2	0,1–0,15	0,25–0,3	0,1–0,2
N.1.1	30 (20–40)	0,1–0,15	0,05–0,1	0,15–0,2	0,1–0,15	0,175–0,25	0,1–0,2
N.1.2	30 (20–40)	0,1–0,15	0,05–0,1	0,15–0,2	0,1–0,15	0,175–0,25	0,1–0,2
N.2.1	15 (10–20)	0,1–0,15	0,05–0,1	0,15–0,2	0,1–0,15	0,175–0,25	0,1–0,2
N.2.2	15 (10–20)	0,1–0,15	0,05–0,1	0,15–0,2	0,1–0,15	0,175–0,25	0,1–0,2
N.2.3							
N.3.1	20 (15–25)	0,1–0,15	0,05–0,1	0,15–0,2	0,1–0,15	0,175–0,25	0,1–0,2
N.3.2	20 (15–25)	0,1–0,15	0,05–0,1	0,15–0,2	0,1–0,15	0,175–0,25	0,1–0,2
N.3.3	20 (15–25)	0,1–0,15	0,05–0,1	0,15–0,2	0,1–0,15	0,175–0,25	0,1–0,2
N.4.1							
S.1.1							
S.1.2							
S.2.1							
S.2.2							
S.2.3							
S.3.1							
S.3.2							
S.3.3							
H.1.1							
H.1.2							
H.1.3							
H.1.4							
H.2.1							
H.3.1							
O.1.1							
O.1.2							
O.2.1							
O.2.2							
O.3.1							

 The cutting data depend extremely on the external conditions, the material and machine type. The indicated values are possible values which have to be increased or reduced, inside the bracket, according to the application conditions.

Cutting data for HSS-E reamers

Index	40 110 ..., 40 115 ...									
	Nominal Ø in mm ▶	≤ Ø 5	Ø 5,01–8	Ø 8,01–12	Ø 12,01–15	Ø 15,01–20	Ø 20,01–25	Ø 25,01–30	Ø 30,01–40	Ø 40,01–50
	Reaming allowance Ø ▶	0,10	0,15	0,20	0,20	0,30	0,30	0,30	0,30	0,30
	v_c (m/min)	f (mm/rev)								
P.1.1	12	0,10	0,15	0,20	0,25	0,30	0,30	0,30	0,40	0,40
P.1.2	12	0,10	0,15	0,20	0,25	0,30	0,30	0,30	0,40	0,40
P.1.3	10	0,10	0,15	0,20	0,25	0,30	0,30	0,30	0,40	0,40
P.1.4	10	0,10	0,15	0,20	0,25	0,30	0,30	0,30	0,40	0,40
P.1.5	10	0,10	0,15	0,20	0,25	0,30	0,30	0,30	0,40	0,40
P.2.1	12	0,10	0,15	0,20	0,25	0,30	0,30	0,30	0,40	0,40
P.2.2	12	0,10	0,15	0,20	0,25	0,30	0,30	0,30	0,40	0,40
P.2.3	10	0,10	0,15	0,20	0,25	0,30	0,30	0,30	0,40	0,40
P.2.4	10	0,10	0,15	0,20	0,25	0,30	0,30	0,30	0,40	0,40
P.3.1	12	0,10	0,15	0,20	0,25	0,30	0,30	0,30	0,40	0,40
P.3.2	10	0,10	0,15	0,20	0,25	0,30	0,30	0,30	0,40	0,40
P.3.3	10	0,10	0,15	0,20	0,25	0,30	0,30	0,30	0,40	0,40
P.4.1										
P.4.2										
M.1.1										
M.2.1										
M.3.1										
K.1.1	12	0,15	0,20	0,25	0,30	0,35	0,35	0,35	0,40	0,40
K.1.2	12	0,15	0,20	0,25	0,30	0,35	0,35	0,35	0,40	0,40
K.2.1	10	0,15	0,20	0,25	0,30	0,35	0,35	0,35	0,40	0,40
K.2.2	10	0,15	0,20	0,25	0,30	0,35	0,35	0,35	0,40	0,40
K.3.1	10	0,15	0,20	0,25	0,30	0,35	0,35	0,35	0,40	0,40
K.3.2	10	0,15	0,20	0,25	0,30	0,35	0,35	0,35	0,40	0,40
N.1.1	15	0,15	0,20	0,20	0,25	0,30	0,30	0,30	0,40	0,40
N.1.2	15	0,15	0,20	0,20	0,25	0,30	0,30	0,30	0,40	0,40
N.2.1										
N.2.2										
N.2.3										
N.3.1	20	0,15	0,20	0,20	0,25	0,30	0,30	0,30	0,40	0,40
N.3.2	20	0,15	0,20	0,20	0,25	0,30	0,30	0,30	0,40	0,40
N.3.3	20	0,15	0,20	0,20	0,25	0,30	0,30	0,30	0,40	0,40
N.4.1										
S.1.1										
S.1.2										
S.2.1										
S.2.2										
S.2.3										
S.3.1										
S.3.2										
S.3.3										
H.1.1										
H.1.2										
H.1.3										
H.1.4										
H.2.1										
H.3.1										
O.1.1	25	0,15	0,20	0,20	0,25	0,30	0,30	0,30	0,40	0,40
O.1.2	25	0,15	0,20	0,20	0,25	0,30	0,30	0,30	0,40	0,40
O.2.1										
O.2.2										
O.3.1										

4

 The cutting data is strongly influenced by external conditions, such as the stability of the tool and workpiece clamping, material and type of machine. The specified values represent guideline cutting data that can be adjusted by approx. ±20% according to the usage conditions.

Cutting data standard values indexable insert countersink

Index	30 196 ..., 30 197 ...			30 198 ...					
	Insert		Tool diameter	Insert		Tool diameter			
	BK8425	K10	Ø 16,5–37	BK8425	K10	Ø 10–15	Ø 15–20	Ø 20–30	Ø 30–48
	v _c (m/min)		f (mm/rev)	v _c (m/min)		f (mm/rev)			
P.1.1	200		0,12–0,16	260		0,06–0,12	0,12–0,20	0,15–0,25	0,20–0,30
P.1.2	200		0,20–0,30	260		0,06–0,12	0,12–0,20	0,15–0,25	0,20–0,30
P.1.3	200		0,20–0,30	270		0,06–0,12	0,12–0,20	0,25–0,40	0,25–0,40
P.1.4	180		0,20–0,30	240		0,06–0,12	0,12–0,20	0,25–0,40	0,25–0,40
P.1.5	180		0,17–0,27	230		0,04–0,08	0,15	0,20–0,30	0,20–0,35
P.2.1	160		0,20–0,30	270		0,06–0,12	0,12–0,20	0,25–0,40	0,25–0,40
P.2.2	160		0,20–0,30	260		0,04–0,08	0,15	0,20–0,30	0,20–0,35
P.2.3	160		0,15–0,20	180		0,04–0,08	0,15	0,20–0,30	0,20–0,35
P.2.4	160		0,10–0,16	150		0,04–0,08	0,15	0,20–0,30	0,20–0,35
P.3.1	140		0,10–0,15	160		0,04–0,08	0,15	0,20–0,30	0,20–0,35
P.3.2	140		0,08–0,13	130		0,04–0,08	0,15	0,20–0,30	0,20–0,35
P.3.3	140		0,06–0,12	120		0,04–0,08	0,15	0,20–0,30	0,20–0,35
P.4.1	120		0,10–0,16	180		0,08	0,15	0,16	0,18
P.4.2	120		0,06–0,12	130		0,08	0,15	0,16	0,18
M.1.1	160		0,10–0,15	150		0,08	0,15	0,16	0,18
M.2.1	140		0,10–0,15	150		0,08	0,15	0,16	0,18
M.3.1	100		0,07–0,13	130		0,08	0,15	0,16	0,18
K.1.1	180		0,40	160		0,15	0,30	0,40	0,60
K.1.2	160		0,32	120		0,15	0,30	0,40	0,60
K.2.1	140		0,30	160		0,15	0,25	0,30	0,35
K.2.2	140		0,18	100		0,12	0,20	0,25	0,35
K.3.1	120		0,20	120		0,10	0,18	0,25	0,30
K.3.2	120		0,18	100		0,10	0,18	0,25	0,30
N.1.1		250	0,20	400	250	0,05	0,12	0,15	0,20
N.1.2		250	0,20	400	250	0,05	0,12	0,15	0,20
N.2.1		250	0,30	250	250	0,06	0,16	0,20	0,25
N.2.2		250	0,30	250	250	0,06	0,16	0,20	0,25
N.2.3		250	0,25	230	250	0,10	0,20	0,25	0,30
N.3.1		230	0,30	200	230	0,05	0,10	0,12	0,15
N.3.2		230	0,32	220	230	0,05	0,10	0,12	0,15
N.3.3		230	0,22	330	230	0,05	0,10	0,12	0,15
N.4.1		230	0,30	200	230	0,05	0,10	0,12	0,15
S.1.1	60	20	0,12		20	0,05	0,10	0,12	0,15
S.1.2	50	20	0,10		20	0,05	0,10	0,12	0,15
S.2.1	60	20	0,12		20	0,05	0,10	0,12	0,15
S.2.2	50	20	0,10		20	0,05	0,10	0,12	0,15
S.2.3	30	20	0,06		20	0,05	0,10	0,12	0,15
S.3.1	100	60	0,22		60	0,05	0,10	0,12	0,15
S.3.2	80	30	0,20		30	0,05	0,10	0,12	0,15
S.3.3	50	30	0,12		30	0,05	0,10	0,12	0,15
H.1.1	100		0,10	100		0,05	0,10	0,15	0,20
H.1.2	80		0,08	80		0,05	0,10	0,15	0,20
H.1.3	50		0,05	50		0,05	0,10	0,15	0,20
H.1.4									
H.2.1	100		0,10	100		0,05	0,10	0,15	0,20
H.3.1	80		0,08	80		0,05	0,10	0,15	0,20
O.1.1		100	0,10		100	0,05	0,12	0,15	0,20
O.1.2		100	0,10		100	0,05	0,12	0,15	0,20
O.2.1									
O.2.2		100	0,03		100	0,05	0,12	0,15	0,20
O.3.1		100	0,08		100	0,05	0,12	0,15	0,20

4

 The cutting data is strongly influenced by external conditions, such as the stability of the tool and workpiece clamping, material and type of machine. The specified values represent guideline cutting data that can be adjusted by approx. ±20% according to the usage conditions.

Cutting data for solid carbide countersinks

Index	30 115 ...						30 160 ...			
	Solid carbide 90°						Solid carbide 60°			
	v _c (m/min)	Ø 8,0 -12,4	Ø 12,4 -16,5	Ø 16,5 -20,5	Ø 20,5 -25,0	Ø 25,0 -31,0	v _c (m/min)	Ø 12,4 -16,5	Ø 16,5 -20,5	Ø 20,5 -25,0
		f (mm/rev)						f (mm/rev)		
P.1.1	40	0,10	0,12	0,14	0,18	0,22	40	0,12	0,14	0,18
P.1.2	40	0,10	0,12	0,14	0,18	0,22	40	0,12	0,14	0,18
P.1.3	30	0,08	0,10	0,10	0,14	0,18	30	0,10	0,10	0,14
P.1.4	30	0,08	0,10	0,12	0,14	0,18	30	0,10	0,12	0,14
P.1.5	18	0,05	0,06	0,08	0,10	0,12	18	0,06	0,08	0,10
P.2.1	30	0,08	0,10	0,12	0,14	0,18	30	0,10	0,12	0,14
P.2.2	20	0,05	0,06	0,08	0,10	0,12	20	0,06	0,08	0,10
P.2.3	18	0,05	0,06	0,08	0,10	0,12	18	0,06	0,08	0,10
P.2.4	18	0,05	0,06	0,08	0,10	0,12	18	0,06	0,08	0,10
P.3.1	18	0,05	0,06	0,08	0,10	0,12	18	0,06	0,08	0,10
P.3.2	18	0,05	0,06	0,08	0,10	0,12	18	0,06	0,08	0,10
P.3.3	18	0,05	0,06	0,08	0,10	0,12	18	0,06	0,08	0,10
P.4.1										
P.4.2										
M.1.1	15	0,06	0,07	0,08	0,09	0,12	15	0,07	0,08	0,09
M.2.1	15	0,06	0,07	0,08	0,09	0,12	15	0,07	0,08	0,09
M.3.1	15	0,06	0,07	0,08	0,09	0,12	15	0,07	0,08	0,09
K.1.1	24	0,12	0,14	0,18	0,20	0,25	24	0,14	0,18	0,20
K.1.2	24	0,12	0,14	0,18	0,20	0,25	24	0,14	0,18	0,20
K.2.1	18	0,12	0,14	0,18	0,20	0,25	18	0,14	0,18	0,20
K.2.2	18	0,12	0,14	0,18	0,20	0,25	18	0,14	0,18	0,20
K.3.1	24	0,12	0,14	0,18	0,20	0,25	24	0,14	0,18	0,20
K.3.2	18	0,12	0,14	0,18	0,20	0,25	18	0,14	0,18	0,20
N.1.1	58	0,12	0,14	0,18	0,22	0,26	58	0,14	0,18	0,22
N.1.2	58	0,12	0,14	0,18	0,22	0,26	58	0,14	0,18	0,22
N.2.1	45	0,12	0,14	0,18	0,22	0,26	45	0,14	0,18	0,22
N.2.2	45	0,12	0,14	0,18	0,22	0,26	45	0,14	0,18	0,22
N.2.3	50	0,14	0,18	0,20	0,24	0,30	50	0,18	0,20	0,24
N.3.1	50	0,14	0,18	0,20	0,24	0,30	50	0,18	0,20	0,24
N.3.2	50	0,14	0,18	0,20	0,24	0,30	50	0,18	0,20	0,24
N.3.3	50	0,14	0,18	0,20	0,24	0,30	50	0,18	0,20	0,24
N.4.1	50	0,14	0,18	0,20	0,24	0,30	50	0,18	0,20	0,24
S.1.1	12	0,05	0,06	0,07	0,08	0,10	12	0,06	0,07	0,08
S.1.2	12	0,05	0,06	0,07	0,08	0,10	12	0,06	0,07	0,08
S.2.1	12	0,05	0,06	0,07	0,08	0,10	12	0,06	0,07	0,08
S.2.2	12	0,05	0,06	0,07	0,08	0,10	12	0,06	0,07	0,08
S.2.3	12	0,05	0,06	0,07	0,08	0,10	12	0,06	0,07	0,08
S.3.1	12	0,05	0,06	0,07	0,08	0,10	12	0,06	0,07	0,08
S.3.2	12	0,05	0,06	0,07	0,08	0,10	12	0,06	0,07	0,08
S.3.3	12	0,05	0,06	0,07	0,08	0,10	12	0,06	0,07	0,08
H.1.1	8	0,06	0,08	0,08	0,10	0,12	8	0,08	0,08	0,10
H.1.2										
H.1.3										
H.1.4										
H.2.1										
H.3.1										
O.1.1										
O.1.2										
O.2.1										
O.2.2										
O.3.1										

 The cutting data is strongly influenced by external conditions, such as the stability of the tool and workpiece clamping, material and type of machine. The specified values represent guideline cutting data that can be adjusted by approx. ±20% according to the usage conditions.

Cutting data standard values for countersinks with irregular pitch

Index	30 117 ...							30 141 ...						
	HPC-TiN / Solid carbide							TiN / HSS						
	N	Ø 4,3–8,0	Ø 8,0–12,4	Ø 12,4–16,5	Ø 16,5–20,5	Ø 20,5–25,0	Ø 25,0–31,0	N	Ø 4,3–8,0	Ø 8,0–12,4	Ø 12,4–16,5	Ø 16,5–20,5	Ø 20,5–25,0	Ø 25,0–31,0
	v _c (m/min)	f (mm/rev)						v _c (m/min)	f (mm/rev)					
P.1.1	58	0,08	0,10	0,12	0,14	0,18	0,22	38	0,08	0,10	0,12	0,14	0,18	0,22
P.1.2	58	0,08	0,10	0,12	0,14	0,18	0,22	38	0,08	0,10	0,12	0,14	0,18	0,22
P.1.3	50	0,06	0,08	0,10	0,10	0,14	0,18	30	0,06	0,08	0,10	0,10	0,14	0,18
P.1.4	50	0,06	0,08	0,10	0,12	0,14	0,18	30	0,06	0,08	0,10	0,12	0,14	0,18
P.1.5	50	0,06	0,05	0,06	0,08	0,10	0,12	30	0,06	0,05	0,06	0,08	0,10	0,12
P.2.1	50	0,06	0,08	0,10	0,12	0,14	0,18	30	0,06	0,08	0,10	0,12	0,14	0,18
P.2.2	50	0,06	0,05	0,06	0,08	0,10	0,12	12	0,06	0,05	0,06	0,08	0,10	0,12
P.2.3	40	0,04	0,05	0,06	0,08	0,10	0,12	12	0,04	0,05	0,06	0,08	0,10	0,12
P.2.4	40	0,04	0,05	0,06	0,08	0,10	0,12	12	0,04	0,05	0,06	0,08	0,10	0,12
P.3.1	50	0,06	0,05	0,06	0,08	0,10	0,12	30	0,06	0,05	0,06	0,08	0,10	0,12
P.3.2	40	0,04	0,05	0,06	0,08	0,10	0,12	12	0,04	0,05	0,06	0,08	0,10	0,12
P.3.3	40	0,04	0,05	0,06	0,08	0,10	0,12	12	0,04	0,05	0,06	0,08	0,10	0,12
P.4.1	30	0,05	0,06	0,07	0,08	0,09	0,12	15	0,05	0,06	0,07	0,08	0,09	0,12
P.4.2	30	0,05	0,06	0,07	0,08	0,09	0,12	15	0,05	0,06	0,07	0,08	0,09	0,12
M.1.1	30	0,05	0,06	0,07	0,08	0,09	0,12	15	0,05	0,06	0,07	0,08	0,09	0,12
M.2.1	30	0,05	0,06	0,07	0,08	0,09	0,12	15	0,05	0,06	0,07	0,08	0,09	0,12
M.3.1	25	0,05	0,06	0,07	0,08	0,09	0,12							
K.1.1	50	0,10	0,12	0,14	0,18	0,20	0,25	20	0,10	0,12	0,14	0,18	0,20	0,25
K.1.2	50	0,10	0,12	0,14	0,18	0,20	0,25	20	0,10	0,12	0,14	0,18	0,20	0,25
K.2.1	45	0,10	0,12	0,14	0,18	0,20	0,25	20	0,10	0,12	0,14	0,18	0,20	0,25
K.2.2	45	0,10	0,12	0,14	0,18	0,20	0,25	20	0,10	0,12	0,14	0,18	0,20	0,25
K.3.1	35	0,10	0,12	0,14	0,18	0,20	0,25	20	0,10	0,12	0,14	0,18	0,20	0,25
K.3.2	35	0,10	0,12	0,14	0,18	0,20	0,25	20	0,10	0,12	0,14	0,18	0,20	0,25
N.1.1	80	0,10	0,12	0,14	0,18	0,22	0,26	48	0,10	0,12	0,14	0,18	0,22	0,26
N.1.2	80	0,10	0,12	0,14	0,18	0,22	0,26	48	0,10	0,12	0,14	0,18	0,22	0,26
N.2.1	60	0,10	0,12	0,14	0,18	0,22	0,26	40	0,10	0,12	0,14	0,18	0,22	0,26
N.2.2	60	0,10	0,12	0,14	0,18	0,22	0,26	40	0,10	0,12	0,14	0,18	0,22	0,26
N.2.3	60	0,10	0,14	0,18	0,20	0,24	0,30	40	0,10	0,14	0,18	0,20	0,24	0,30
N.3.1	68	0,12	0,14	0,18	0,20	0,24	0,30	40	0,12	0,14	0,18	0,20	0,24	0,30
N.3.2	68	0,12	0,14	0,18	0,20	0,24	0,30	40	0,12	0,14	0,18	0,20	0,24	0,30
N.3.3	68	0,12	0,14	0,18	0,20	0,24	0,30	40	0,12	0,14	0,18	0,20	0,24	0,30
N.4.1														
S.1.1	15	0,05	0,06	0,07	0,08	0,09	0,10	10	0,05	0,06	0,07	0,08	0,09	0,10
S.1.2	15	0,05	0,06	0,07	0,08	0,09	0,10	10	0,05	0,06	0,07	0,08	0,09	0,10
S.2.1	15	0,05	0,06	0,07	0,08	0,09	0,10	10	0,05	0,06	0,07	0,08	0,09	0,10
S.2.2	15	0,05	0,06	0,07	0,08	0,09	0,10	10	0,05	0,06	0,07	0,08	0,09	0,10
S.2.3	15	0,05	0,06	0,07	0,08	0,09	0,10	10	0,05	0,06	0,07	0,08	0,09	0,10
S.3.1	15	0,05	0,06	0,07	0,08	0,09	0,10	10	0,05	0,06	0,07	0,08	0,09	0,10
S.3.2	15	0,05	0,06	0,07	0,08	0,09	0,10	10	0,05	0,06	0,07	0,08	0,09	0,10
S.3.3	15	0,05	0,06	0,07	0,08	0,09	0,10	10	0,05	0,06	0,07	0,08	0,09	0,10
H.1.1	12	0,05	0,06	0,07	0,07	0,08		6	0,05	0,06	0,07	0,07	0,08	
H.1.2	8	0,05	0,06	0,07	0,07	0,08								
H.1.3														
H.1.4														
H.2.1	12	0,05	0,06	0,07	0,07	0,08								
H.3.1														
O.1.1	68	0,12	0,14	0,18	0,20	0,24	0,30	38	0,12	0,14	0,18	0,20	0,24	0,30
O.1.2	68	0,12	0,14	0,18	0,20	0,24	0,30	38	0,12	0,14	0,18	0,20	0,24	0,30
O.2.1	25	0,10	0,12	0,14	0,18	0,20	0,25							
O.2.2	25	0,10	0,12	0,14	0,18	0,20	0,25							
O.3.1	25	0,10	0,12	0,14	0,18	0,20	0,25							

4

 The cutting data is strongly influenced by external conditions, such as the stability of the tool and workpiece clamping, material and type of machine. The specified values represent guideline cutting data that can be adjusted by approx. ±20% according to the usage conditions.

Cutting data standard values for HSS countersink

Index	30 100 ...							30 102 ...						
	Type N							Type AL						
	N	Ø 4,3–8,0	Ø 8,0–12,4	Ø 12,4–16,5	Ø 16,5–20,5	Ø 20,5–25,0	Ø 25,0–31,0	AL	Ø 4,3–8,0	Ø 8,0–12,4	Ø 12,4–16,5	Ø 16,5–20,5	Ø 20,5–25,0	Ø 25,0–31,0
	v_c (m/min)	f (mm/rev)						v_c (m/min)	f (mm/rev)					
P.1.1	30	0,06–0,08	0,10	0,12	0,14	0,18	0,22	30	0,06–0,08	0,10	0,12	0,14	0,18	0,22
P.1.2	30	0,06–0,08	0,10	0,12	0,14	0,18	0,22	30	0,06–0,08	0,10	0,12	0,14	0,18	0,22
P.1.3	25	0,04–0,06	0,04–0,06	0,08	0,10	0,12	0,14	25	0,04–0,06	0,04–0,06	0,08	0,10	0,12	0,14
P.1.4	25	0,04–0,06	0,04–0,06	0,08	0,10	0,12	0,14	25	0,04–0,06	0,04–0,06	0,08	0,10	0,12	0,14
P.1.5	12	0,03–0,04	0,05	0,06	0,08	0,10	0,12	12	0,03–0,04	0,05	0,06	0,08	0,10	0,12
P.2.1	25	0,04–0,06	0,08	0,10	0,12	0,14	0,18	25	0,04–0,06	0,08	0,10	0,12	0,14	0,18
P.2.2	10	0,03–0,04	0,05	0,06	0,08	0,10	0,12	10	0,03–0,04	0,05	0,06	0,08	0,10	0,12
P.2.3	10	0,03–0,04	0,05	0,06	0,08	0,10	0,12	10	0,03–0,04	0,05	0,06	0,08	0,10	0,12
P.2.4	10	0,03–0,04	0,05	0,06	0,08	0,10	0,12	10	0,03–0,04	0,05	0,06	0,08	0,10	0,12
P.3.1	10	0,03–0,04	0,05	0,06	0,08	0,10	0,12	10	0,03–0,04	0,05	0,06	0,08	0,10	0,12
P.3.2	10	0,03–0,04	0,05	0,06	0,08	0,10	0,12	10	0,03–0,04	0,05	0,06	0,08	0,10	0,12
P.3.3	10	0,03–0,04	0,05	0,06	0,08	0,10	0,12	10	0,03–0,04	0,05	0,06	0,08	0,10	0,12
P.4.1														
P.4.2														
M.1.1	8	0,04–0,05	0,06	0,07	0,08	0,09	0,12	8	0,04–0,05	0,06	0,07	0,08	0,09	0,12
M.2.1	8	0,04–0,05	0,06	0,07	0,08	0,09	0,12	8	0,04–0,05	0,06	0,07	0,08	0,09	0,12
M.3.1	8	0,04–0,05	0,06	0,07	0,08	0,09	0,12	8	0,04–0,05	0,06	0,07	0,08	0,09	0,12
K.1.1	12	0,06–0,10	0,12	0,14	0,18	0,20	0,25	12	0,06–0,10	0,12	0,14	0,18	0,20	0,25
K.1.2	12	0,06–0,10	0,12	0,14	0,18	0,20	0,25	12	0,06–0,10	0,12	0,14	0,18	0,20	0,25
K.2.1	10	0,06–0,10	0,12	0,14	0,18	0,20	0,25	10	0,06–0,10	0,12	0,14	0,18	0,20	0,25
K.2.2	10	0,06–0,10	0,12	0,14	0,18	0,20	0,25	10	0,06–0,10	0,12	0,14	0,18	0,20	0,25
K.3.1	12	0,06–0,10	0,12	0,14	0,18	0,20	0,25	12	0,06–0,10	0,12	0,14	0,18	0,20	0,25
K.3.2	10	0,06–0,10	0,12	0,14	0,18	0,20	0,25	10	0,06–0,10	0,12	0,14	0,18	0,20	0,25
N.1.1	35	0,08–0,10	0,12	0,14	0,18	0,22	0,26	39	0,08–0,10	0,12	0,14	0,18	0,22	0,26
N.1.2	35	0,08–0,10	0,12	0,14	0,18	0,22	0,26	39	0,08–0,10	0,12	0,14	0,18	0,22	0,26
N.2.1	25	0,08–0,10	0,12	0,14	0,18	0,22	0,26	28	0,08–0,10	0,12	0,14	0,18	0,22	0,26
N.2.2	25	0,08–0,10	0,12	0,14	0,18	0,22	0,26	28	0,08–0,10	0,12	0,14	0,18	0,22	0,26
N.2.3	25	0,08–0,10	0,12	0,14	0,18	0,22	0,26	28	0,08–0,10	0,12	0,14	0,18	0,22	0,26
N.3.1	35	0,10–0,12	0,14	0,18	0,20	0,24	0,30	39	0,10–0,12	0,14	0,18	0,20	0,24	0,30
N.3.2	35	0,10–0,12	0,14	0,18	0,20	0,24	0,30	39	0,10–0,12	0,14	0,18	0,20	0,24	0,30
N.3.3	35	0,10–0,12	0,14	0,18	0,20	0,24	0,30	39	0,10–0,12	0,14	0,18	0,20	0,24	0,30
N.4.1	60	0,10–0,13	0,16	0,20	0,23	0,26	0,30	66	0,10–0,13	0,16	0,20	0,23	0,26	0,30
S.1.1	8	0,04–0,05	0,06	0,07	0,08	0,09	0,12	8	0,04–0,05	0,06	0,07	0,08	0,09	0,12
S.1.2	8	0,04–0,05	0,06	0,07	0,08	0,09	0,12	8	0,04–0,05	0,06	0,07	0,08	0,09	0,12
S.2.1	8	0,04–0,05	0,06	0,07	0,08	0,09	0,12	8	0,04–0,05	0,06	0,07	0,08	0,09	0,12
S.2.2	8	0,04–0,05	0,06	0,07	0,08	0,09	0,12	8	0,04–0,05	0,06	0,07	0,08	0,09	0,12
S.2.3	8	0,04–0,05	0,06	0,07	0,08	0,09	0,12	8	0,04–0,05	0,06	0,07	0,08	0,09	0,12
S.3.1	8	0,04–0,05	0,06	0,07	0,08	0,09	0,12	8	0,04–0,05	0,06	0,07	0,08	0,09	0,12
S.3.2	8	0,04–0,05	0,06	0,07	0,08	0,09	0,12	8	0,04–0,05	0,06	0,07	0,08	0,09	0,12
S.3.3	8	0,04–0,05	0,06	0,07	0,08	0,09	0,12	8	0,04–0,05	0,06	0,07	0,08	0,09	0,12
H.1.1														
H.1.2														
H.1.3														
H.1.4														
H.2.1														
H.3.1														
O.1.1	35	0,10–0,12	0,14	0,18	0,20	0,24	0,30	35	0,10–0,12	0,14	0,18	0,20	0,24	0,30
O.1.2	35	0,10–0,12	0,14	0,18	0,20	0,24	0,30	35	0,10–0,12	0,14	0,18	0,20	0,24	0,30
O.2.1	35	0,10–0,12	0,14	0,18	0,20	0,24	0,30	35	0,10–0,12	0,14	0,18	0,20	0,24	0,30
O.2.2	35	0,10–0,12	0,14	0,18	0,20	0,24	0,30	35	0,10–0,12	0,14	0,18	0,20	0,24	0,30
O.3.1														

 The cutting data is strongly influenced by external conditions, such as the stability of the tool and workpiece clamping, material and type of machine. The specified values represent guideline cutting data that can be adjusted by approx. ±20% according to the usage conditions.

Cutting data standard values for HSS countersink and counterbore

Index	30 105 ..., 30 150 ..., 30 170 ... HSS – 60° / 90° / 120°									30 190 ..., 30 191 ... HSS			
		Ø 4,3–8,0	Ø 8,0–12,4	Ø 12,4–16,5	Ø 16,5–20,5	Ø 20,5–25,0	Ø 25,0–31,0	Ø 31,0–55,0	Ø 55,0–80,0		DC_2 Ø 6,3	DC_2 Ø 10,0	DC_2 Ø 14,0
	v _c (m/min)	f (mm/rev)								v _c (m/min)	f (mm/rev)		
P.1.1	30	0,06–0,08	0,10	0,12	0,14	0,18	0,22	0,22–0,26	0,26–0,36	30	0,07	0,10	0,12
P.1.2	30	0,06–0,08	0,10	0,12	0,14	0,18	0,22	0,22–0,26	0,26–0,36	30	0,07	0,10	0,12
P.1.3	25	0,04–0,06	0,04–0,06	0,08	0,10	0,12	0,14	0,14–0,22	0,22–0,28	25	0,05	0,07	0,09
P.1.4	25	0,04–0,06	0,04–0,06	0,08	0,10	0,12	0,14	0,14–0,22	0,22–0,28	25	0,05	0,07	0,09
P.1.5	12	0,03–0,04	0,05	0,06	0,08	0,10	0,12	0,12–0,14	0,14–0,18	12	0,04	0,05	0,07
P.2.1	25	0,04–0,06	0,08	0,10	0,12	0,14	0,18	0,18–0,24	0,24–0,30	25	0,05	0,07	0,09
P.2.2	10	0,03–0,04	0,05	0,06	0,08	0,10	0,12	0,12–0,16	0,16–0,18	10	0,04	0,05	0,06
P.2.3	10	0,03–0,04	0,05	0,06	0,08	0,10	0,12	0,12–0,16	0,16–0,18	10	0,04	0,05	0,06
P.2.4	10	0,03–0,04	0,05	0,06	0,08	0,10	0,12	0,12–0,16	0,16–0,18	10	0,04	0,05	0,06
P.3.1	10	0,03–0,04	0,05	0,06	0,08	0,10	0,12	0,12–0,16	0,16–0,18	10	0,04	0,05	0,06
P.3.2	10	0,03–0,04	0,05	0,06	0,08	0,10	0,12	0,12–0,16	0,16–0,18	10	0,04	0,05	0,06
P.3.3	10	0,03–0,04	0,05	0,06	0,08	0,10	0,12	0,12–0,16	0,16–0,18	10	0,04	0,05	0,06
P.4.1													
P.4.2													
M.1.1	8	0,04–0,05	0,06	0,07	0,08	0,09	0,12	0,12–0,16	0,16–0,18	8	0,04	0,06	0,07
M.2.1	8	0,04–0,05	0,06	0,07	0,08	0,09	0,12	0,12–0,16	0,16–0,18	8	0,04	0,06	0,07
M.3.1	8	0,04–0,05	0,06	0,07	0,08	0,09	0,12	0,12–0,16	0,16–0,18	8	0,04	0,06	0,07
K.1.1	12	0,06–0,10	0,12	0,14	0,18	0,20	0,25	0,25–0,27	0,27–0,36	12	0,08	0,13	0,16
K.1.2	12	0,06–0,10	0,12	0,14	0,18	0,20	0,25	0,25–0,27	0,27–0,36	12	0,08	0,13	0,16
K.2.1	10	0,06–0,10	0,12	0,14	0,18	0,20	0,25	0,25–0,27	0,27–0,36	10	0,08	0,13	0,16
K.2.2	10	0,06–0,10	0,12	0,14	0,18	0,20	0,25	0,25–0,27	0,27–0,36	10	0,08	0,13	0,16
K.3.1	12	0,06–0,10	0,12	0,14	0,18	0,20	0,25	0,25–0,27	0,27–0,36	12	0,08	0,13	0,16
K.3.2	10	0,06–0,10	0,12	0,14	0,18	0,20	0,25	0,25–0,27	0,27–0,36	10	0,08	0,13	0,16
N.1.1	35	0,08–0,10	0,12	0,14	0,18	0,22	0,26	0,26–0,34	0,34–0,40	35	0,09	0,13	0,16
N.1.2	35	0,08–0,10	0,12	0,14	0,18	0,22	0,26	0,26–0,34	0,34–0,40	35	0,09	0,13	0,16
N.2.1	25	0,08–0,10	0,12	0,14	0,18	0,22	0,26	0,26–0,34	0,34–0,40	25	0,09	0,13	0,16
N.2.2	25	0,08–0,10	0,12	0,14	0,18	0,22	0,26	0,26–0,34	0,34–0,40	25	0,09	0,13	0,16
N.2.3	25	0,08–0,10	0,12	0,14	0,18	0,22	0,26	0,26–0,34	0,34–0,40	25	0,09	0,13	0,16
N.3.1	35	0,10–0,12	0,14	0,18	0,20	0,24	0,30	0,30–0,42	0,42–0,46	35	0,11	0,16	0,18
N.3.2	35	0,10–0,12	0,14	0,18	0,20	0,24	0,30	0,30–0,42	0,42–0,46	35	0,11	0,16	0,18
N.3.3	35	0,10–0,12	0,14	0,18	0,20	0,24	0,30	0,30–0,42	0,42–0,46	35	0,11	0,16	0,18
N.4.1	60	0,10–0,13	0,16	0,20	0,23	0,26	0,30	0,30–0,42	0,42–0,46	60	0,12	0,18	0,21
S.1.1	8	0,04–0,05	0,06	0,07	0,08	0,09	0,12	0,12	0,12	8	0,04	0,06	0,07
S.1.2	8	0,04–0,05	0,06	0,07	0,08	0,09	0,12	0,12	0,12	8	0,04	0,06	0,07
S.2.1	8	0,04–0,05	0,06	0,07	0,08	0,09	0,12	0,12	0,12	8	0,04	0,06	0,07
S.2.2	8	0,04–0,05	0,06	0,07	0,08	0,09	0,12	0,12	0,12	8	0,04	0,06	0,07
S.2.3	8	0,04–0,05	0,06	0,07	0,08	0,09	0,12	0,12	0,12	8	0,04	0,06	0,07
S.3.1	8	0,04–0,05	0,06	0,07	0,08	0,09	0,12	0,12	0,12	8	0,04	0,06	0,07
S.3.2	8	0,04–0,05	0,06	0,07	0,08	0,09	0,12	0,12	0,12	8	0,04	0,06	0,07
S.3.3	8	0,04–0,05	0,06	0,07	0,08	0,09	0,12	0,12	0,12	8	0,04	0,06	0,07
H.1.1													
H.1.2													
H.1.3													
H.1.4													
H.2.1													
H.3.1													
O.1.1	35	0,10–0,12	0,14	0,18	0,20	0,24	0,30	0,30	0,30	35	0,11	0,16	0,18
O.1.2	35	0,10–0,12	0,14	0,18	0,20	0,24	0,30	0,30	0,30	35	0,11	0,16	0,18
O.2.1	35	0,10–0,12	0,14	0,18	0,20	0,24	0,30	0,30	0,30	35	0,11	0,16	0,18
O.2.2	35	0,10–0,12	0,14	0,18	0,20	0,24	0,30	0,30	0,30	35	0,11	0,16	0,18
O.3.1													

 The cutting data is strongly influenced by external conditions, such as the stability of the tool and workpiece clamping, material and type of machine. The specified values represent guideline cutting data that can be adjusted by approx. ±20% according to the usage conditions.

Cutting data standard values for HSS-E deburring countersink

Index	30 120 ..., 30 121 ...						
	HSS-E – 90°						
	TiN	uncoated	Ø 6,3	Ø 10,0	Ø 14,0	Ø 21,0	Ø 28,0
	v _c (m/min)		f (mm/rev)				
P.1.1	35	30	0,06–0,08	0,10	0,12	0,14	0,18
P.1.2	35	30	0,06–0,08	0,10	0,12	0,14	0,18
P.1.3	29	25	0,04–0,06	0,04–0,06	0,08	0,10	0,12
P.1.4	29	25	0,04–0,06	0,04–0,06	0,08	0,10	0,12
P.1.5	14	12	0,03–0,04	0,05	0,06	0,08	0,10
P.2.1	29	25	0,04–0,06	0,08	0,10	0,12	0,14
P.2.2	12	10	0,03–0,04	0,05	0,06	0,08	0,10
P.2.3	12	10	0,03–0,04	0,05	0,06	0,08	0,10
P.2.4	12	10	0,03–0,04	0,05	0,06	0,08	0,10
P.3.1	12	10	0,03–0,04	0,05	0,06	0,08	0,10
P.3.2	12	10	0,03–0,04	0,05	0,06	0,08	0,10
P.3.3	12	10	0,03–0,04	0,05	0,06	0,08	0,10
P.4.1							
P.4.2							
M.1.1	9	8	0,04–0,05	0,06	0,07	0,08	0,09
M.2.1	9	8	0,04–0,05	0,06	0,07	0,08	0,09
M.3.1	9	8	0,04–0,05	0,06	0,07	0,08	0,09
K.1.1	9	12	0,06–0,10	0,12	0,14	0,18	0,20
K.1.2	9	12	0,06–0,10	0,12	0,14	0,18	0,20
K.2.1	9	10	0,06–0,10	0,12	0,14	0,18	0,20
K.2.2	14	10	0,06–0,10	0,12	0,14	0,18	0,20
K.3.1	14	12	0,06–0,10	0,12	0,14	0,18	0,20
K.3.2	12	10	0,06–0,10	0,12	0,14	0,18	0,20
N.1.1	40	35	0,08–0,1	0,12	0,14	0,18	0,22
N.1.2	40	35	0,08–0,1	0,12	0,14	0,18	0,22
N.2.1	29	25	0,08–0,1	0,12	0,14	0,18	0,22
N.2.2	29	25	0,08–0,1	0,12	0,14	0,18	0,22
N.2.3	29	25	0,08–0,1	0,12	0,14	0,18	0,22
N.3.1	40	35	0,1–0,12	0,14	0,18	0,20	0,24
N.3.2	40	35	0,1–0,12	0,14	0,18	0,20	0,24
N.3.3	40	35	0,1–0,12	0,14	0,18	0,20	0,24
N.4.1	69	60	0,1–0,13	0,16	0,20	0,23	0,26
S.1.1	9	8	0,04–0,05	0,06	0,07	0,08	0,09
S.1.2	9	8	0,04–0,05	0,06	0,07	0,08	0,09
S.2.1	9	8	0,04–0,05	0,06	0,07	0,08	0,09
S.2.2	9	8	0,04–0,05	0,06	0,07	0,08	0,09
S.2.3	9	8	0,04–0,05	0,06	0,07	0,08	0,09
S.3.1	9	8	0,04–0,05	0,06	0,07	0,08	0,09
S.3.2	9	8	0,04–0,05	0,06	0,07	0,08	0,09
S.3.3	9	8	0,04–0,05	0,06	0,07	0,08	0,09
H.1.1	4		0,04–0,05	0,06	0,07	0,08	0,10
H.1.2							
H.1.3							
H.1.4							
H.2.1							
H.3.1	4		0,04–0,05	0,06	0,07	0,08	0,10
O.1.1	40	35	0,1–0,12	0,14	0,18	0,20	0,24
O.1.2	40	35	0,1–0,12	0,14	0,18	0,20	0,24
O.2.1	40	35	0,1–0,12	0,14	0,18	0,20	0,24
O.2.2	40	35	0,1–0,12	0,14	0,18	0,20	0,24
O.3.1							

4

 The cutting data is strongly influenced by external conditions, such as the stability of the tool and workpiece clamping, material and type of machine. The specified values represent guideline cutting data that can be adjusted by approx. ±20% according to the usage conditions.

REAMAX TS – Assembly instructions

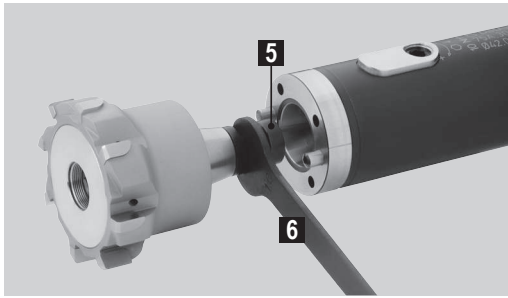

Clean the Morse taper adapter/face contact → grease-free.
Screw the pull stud (5) into the reaming head and tighten using the open-ended spanner (6).

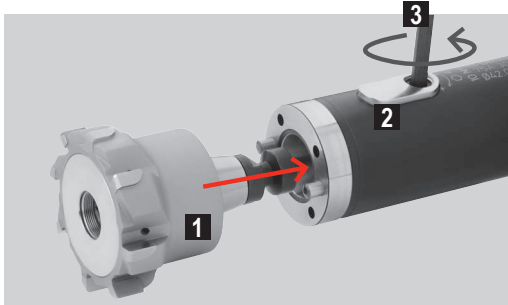

Use key (3) to open jaws (2), but do not fully release, and insert reaming head (1).

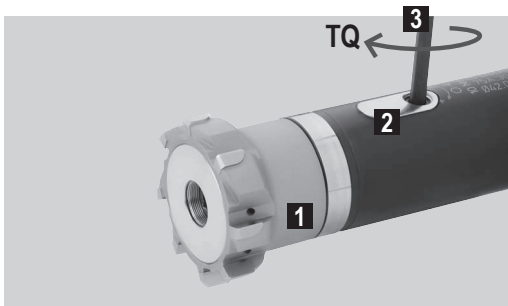

Use the key (3) to close the jaws (2), observe the recommended tightening torque.
When inserting the reaming head (1), this is pulled into its final position when the jaws (2) are closed.

Ø Range	Tightening torque (TQ)
18,000 – 19,999	1,5 Nm
20,000 – 21,999	2,5 Nm
22,000 – 26,999	4 Nm
27,000 – 34,999	5 Nm
35,000 – 41,999	6 Nm
42,000 – 51,999	10 Nm
52,000 – 65,000	13 Nm

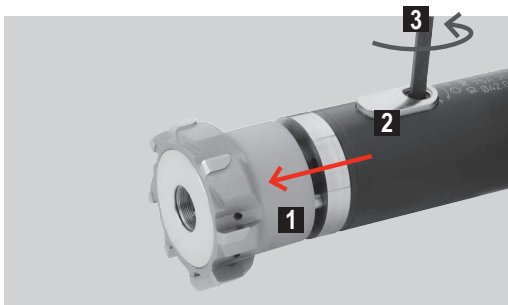

When removing the reamer head (1), this is pressed out of its position by the jaws (2) and can thus be easily removed from the holder:
Use key (3) to open the jaws (2) but do not fully release, and remove reamer head (1).

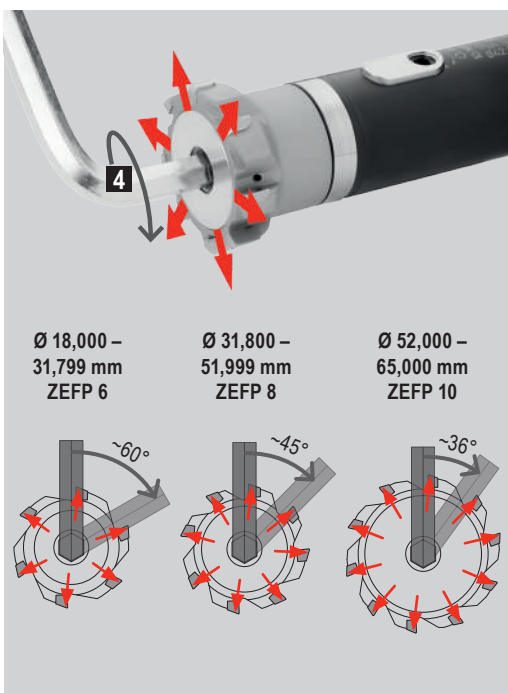

Adjustment for wear compensation:
The smallest drilling tolerances up to IT4 can be achieved through adjustment with the hex key (4).

ZEFP = Number of effective cutting edges, around the periphery	ZEFP 6		ZEFP 8		ZEFP 10	
Pitch	~ 60°		~ 45°		~ 36°	
Turning the hex key by ~ ...°, results in an adjustment of ~ ... mm in diameter	~ 15°	~ 0,006 mm in the Ø	~ 15°	~ 0,003 mm in the Ø	~ 18°	~ 0,005 mm in the Ø
	~ 30°	~ 0,012 mm in the Ø	~ 30°	~ 0,006 mm in the Ø	~ 36°	~ 0,010 mm in the Ø
	~ 45°	~ 0,018 mm in the Ø	~ 45°	~ 0,009 mm in the Ø		
	~ 60°	~ 0,024 mm in the Ø				

Caution: For technical reasons, all REAMAX TS reaming heads and Monomax reamers have an irregular cutting edge pitch. For this reason, the angles specified above are approximate values, to make handling easier. If the required diameter is over turned, turning back the adjustment screw is not enough! If this occurs, the reaming head/reamer must be fully released and re-set again. This adjustment facility is only intended to compensate for wear. Therefore, an adjustment of 0.015 mm in diameter should not normally be exceeded!
The adjustment values given above are recommended values based on empirical values and test results. However, these may vary slightly from case to case.

REAMAX TS – Operating instructions

Aligning the DAH Zero holder

The tool is recommended for radial alignment of max. 20 µm.

1. Loosen all adjustment screws and pre-load with 1 Nm (new tools are already supplied like this).
2. Place dial gauge with µm display on the ground bezel diameter.
3. Turn the tool to determine the point with the largest runout error using the dial gauge.
4. Adjust the corresponding adjustment screw with the hex key clockwise (1) until half the runout error has been corrected. In doing so, over-tighten by approx. 5 µm.
5. Release the opposite adjustment screw (2) by the over-tightened amount.
6. Adjust all 4 adjustment screws until the runout is < 2 µm.

4

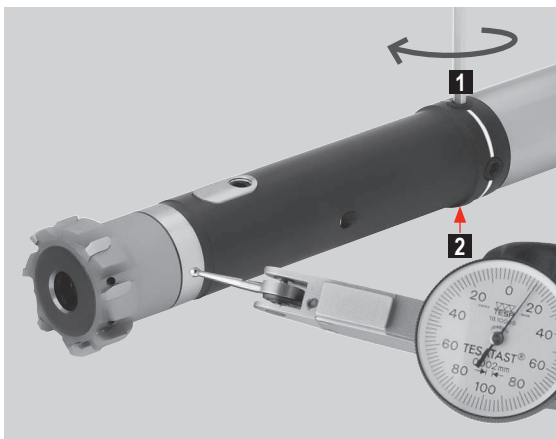

Please note:

- ▲ The runout must be checked and if necessary re-aligned after an adapter changeover, change of application, after any adjustment for wear compensation and before every re-commissioning, using adjustment steps 1 to 6
- ▲ Adjustment screws must always be tightened during usage with at least 1 Nm
- ▲ The max. re-adjustment torque is 4.5 Nm

Please note:

- ▲ Both measurement cutting edges are marked on the reaming head by a dot. Please use only this pair of cutting edges for mechanical measurement. Using other pairs of cutting edges will result in measurement errors.
- ▲ Measure the diameter at the front on the cutting edge due to back taper (see diagram)
- ▲ Please also avoid damage to the cutting edges during the measurement process.

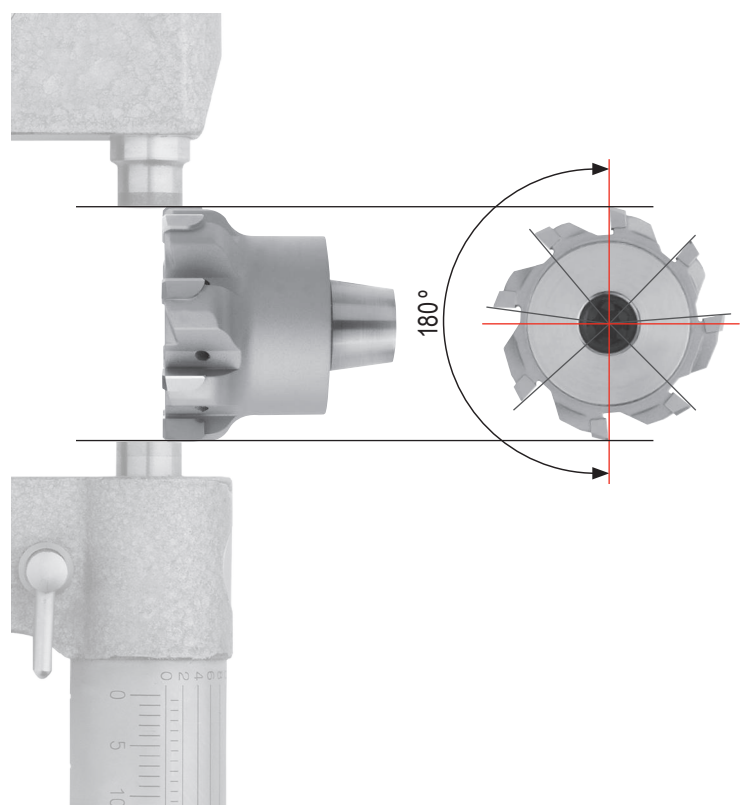

Problems / possible causes / solutions

Hole too large

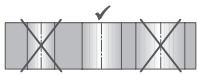

- ▲ Runout error for reamer in the spindle → use DAH compensation system and correct runout
- ▲ Inaccurate alignment, reamer back-cuts → correct alignment and use DPS floating holder
- ▲ Built-up edge → reduce cutting speed v_c for uncoated carbide cutting material, increase it for DST and coated cutting material or increase the oil content of the coolant
- ▲ Reamer too large → have reamer adapted

Hole too small

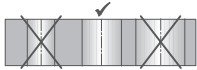

- ▲ Worn reamer → have reamer adjusted, replaced or repaired
- ▲ Reaming allowance too small → increase reaming allowance
- ▲ Cutting force too high → reduce feed or select other lead geometry (ASG)
- ▲ Reamer too small → have reamer adjusted, replaced or repaired

Conical hole, tapered backwards

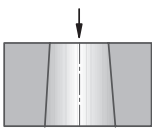

- ▲ Inaccurate alignment → correct alignment and use DPS floating holder
- ▲ Misalignment between headstock and turret → correct turret and use DPS floating holder

Conical hole, tapered forwards

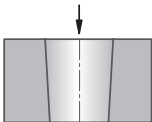

- ▲ Poor alignment, cutting edges push initially → correct alignment and use DPS floating holder

Hole is not round

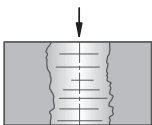

- ▲ Reamer runout error too large → correct the runout with DAH compensation system
- ▲ Alignment error → correct alignment error and use DPS floating holder
- ▲ Asymmetric initial cutting through angled entry surface → countersink hole
- ▲ Workpiece tensioning → correct clamping of the workpieces
- ▲ Poor pre-machining → optimise pre-machining
- ▲ Feed too high → reduce feed

Hole exhibits chatter marks

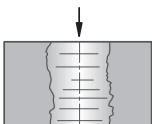

- ▲ Cutting speed v_c too high → reduce cutting speed
- ▲ L to D ratio too high → reduce the speed of entry, pilot the bore or select other lead geometry (ASG)

Non clean-up

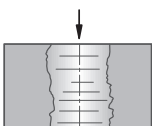

- ▲ Built-up edge → reduce cutting speed v_c for uncoated carbide cutting material, increase it for DST and coated cutting material or increase the oil content of the coolant
- ▲ Cutting edge worn → have cutting edge repaired or replace the tool
- ▲ Reamer runout error → correct the runout with DAH compensation system
- ▲ No or insufficient cooling, chips are getting trapped → use thro' coolant supply and increase coolant pressure
- ▲ Unsuitable coolant → increase the oil content of the coolant
- ▲ Incorrect cutting data → use data according to catalogue recommendation

Grooves in the hole "Feed marking"

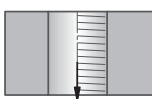

- ▲ Faulty cutting edge (edge breakage) → have reamer replaced or repaired
- ▲ Built-up edges → reduce cutting speed v_c for uncoated carbide cutting material, increase it for DST and coated cutting material or increase the oil content of the coolant

Grooves in the hole "Retraction marking"

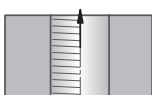

- ▲ Cutting edges moved too far out of the hole → move no more than lead length + 2 mm out of the hole
- ▲ Material springs back → do not retract at high speed but with increased (2-3 times) feed rate

Types of wear

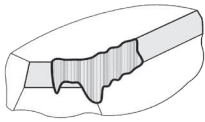

Wear on clearance face

Reduce the cutting speed and select a more wear resistant cutting material or coating.

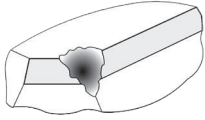

Cutting edge breakage

Reduce feed and reaming allowance. In the case of interrupted holes, use coated carbide instead of DST.

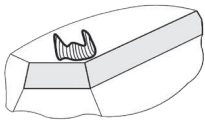

Cratering

Reduce the cutting speed and use a positive cutting edge geometry.

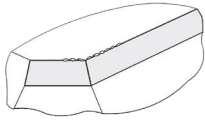

Edge breakages

Increase the cutting speed and use larger rake angle.

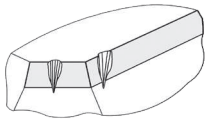

Notch wear

Reduce the cutting speed and select a more wear resistant cutting material or coating.

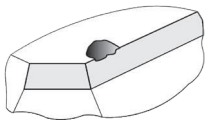

Fatigue fracture

Reduce feed, increase reamer stability.

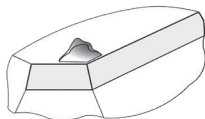

Built-up edge

Use positive cutting edge geometry, increase the oil content of the coolant, reduce the cutting speed v_c for uncoated carbide cutting material, increase it for DST and coated cutting material.

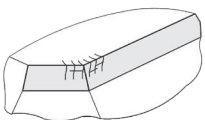

Cracks at right angles to the cutting edge

Use sufficient coolant and thro' coolant, reduce the cutting speed.

Common cutting edge geometries in the performance area

REAMAX, REAMAX TS, Monomax			
Standard geometries			
Cutting edge geometry	Flute type	Chip flow	Lead angle
Through hole			
ASG4000	straight		
Through hole-Blind hole			
ASG3000	straight		
ASG0706	straight		
ASG0106	straight		
Special geometries			
Cutting edge geometry	Flute type	Chip flow Comments	Lead angle
ASG0703	straight	Leading edge	
ASG0704	straight	Leading edge with increased positional accuracy	
ASG09B	straight	Swarf control $\lt; \varnothing 32 \text{ mm}$	
ASG1402	straight	Swarf control $\gt; \varnothing 32 \text{ mm}$	
ASG02	straight		
ASG03	straight		
ASG05	left-handed		

Fullmax			
Standard geometries			
Cutting edge geometry	Flute type	Chip flow	Lead angle
Through hole			
ASG2210	left-hand helix		
ASG2231	left-hand helix		
ASG2270	straight		
Blind hole			
ASG2110	straight		
ASG2131	straight		
ASG2170	straight		
Through hole-Blind hole			
ASG2350	straight		
ASG2360	straight		

Numerous other cutting edge geometries, especially for your application, are available on request. Simply contact our technicians or use the form „Semi standard – Solid carbide reamer“ on our homepage in the download area.

Achievable surface quality

		Roughness ▶	N11	N10	N9	N8	N7	N6	N5	N4	N3	N2	N1
Average roughness R_a ▶			25	12,5	6,3	3,2	1,6	0,8	0,4	0,2	0,1	0,05	0,025
Surface roughness R_z ▶			100	63	40	25	16	10	6,3	4	2,5	1,6	1
Material group	P	1.0 – 4.2											
	M	1.1 – 3.1											
	K	1.1 + 2.1 + 3.1											
		1.2 + 2.2 + 3.2											
	N	1.1 – 2.3											
		3.1 – 3.3											
	S	1.1 – 3.3											
H	1.1 – 1.3												

reachable conditionally reachable

This information is based on experience and may vary from case to case, depending on the prevailing conditions.
(all other surface values on request)

Manufacturer's tolerance of the reamers

T = Hole tolerance field

D = Manufacturer's tolerance of the reamer

max. hole-Ø

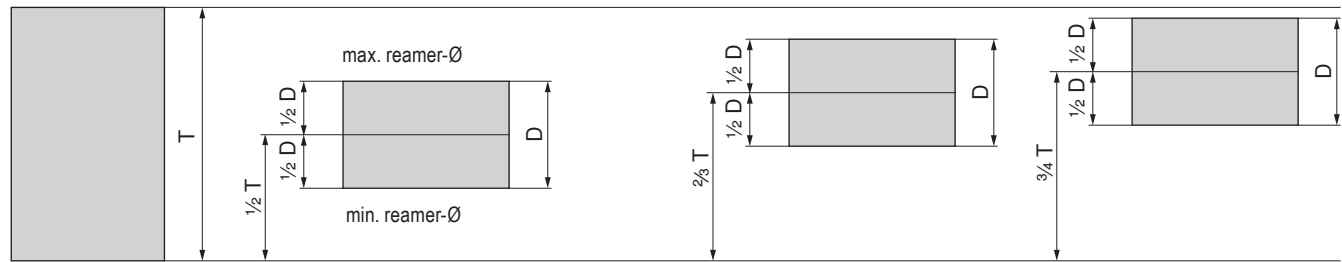

min. hole-Ø

Manufacturer's tolerance of adjustable reamers

The diameter of an adjustable reamer is ground to the middle of drilling tolerance T (REAMAX TS / Monomax). The adjustment capability of the reamer facilitates wear compensation.

Manufacturer's tolerance of fixed reamers

The manufacturer tolerance D of fixed reamers is two thirds (REAMAX) or three quarters (Fullmax) of the drilling tolerance T.

Coatings – Reaming and Countersinking

<p>HPC TiN</p>	<ul style="list-style-type: none"> ▲ Nanostructured TiN multilayer coating ▲ Friction-optimised top layer enables process-secure dry hard machining ▲ Extreme resistance to oxidation and elevated-temperature hardness ▲ Maximum application temperature: 900 °C 	<p>DBG-U</p>	<ul style="list-style-type: none"> ▲ AlTiN Multilayer coating ▲ Especially for universal use in a variety of materials as well as for the machining of tempered materials < 62 HRC ▲ For high cutting speeds and suitable for MMS application ▲ Maximum application temperature: 1000 °C
<p>TiN</p>	<ul style="list-style-type: none"> ▲ TiN coating ▲ Maximum application temperature: 450 °C 	<p>DBG-P</p>	<ul style="list-style-type: none"> ▲ AlTiN Multilayer coating ▲ Especially for universal use in a variety of materials at high cutting speeds ▲ Suitable for MMS application ▲ Maximum application temperature: 1000 °C
<p>TiAlN</p>	<ul style="list-style-type: none"> ▲ TiAlN multilayer coating ▲ Maximum application temperature: 900 °C 	<p>DBC-N</p>	<ul style="list-style-type: none"> ▲ Diamond-like ta-C-Multilayer-carbon coating ▲ Particularly hard and smooth coating and therefore especially for machining non-ferrous metals ▲ Maximum application temperature: 500 °C
<p>TiAlSiN</p>	<ul style="list-style-type: none"> ▲ TiAlSiN- Multilayer coating ▲ Maximum application temperature: 800 °C ▲ Specially designed for machining hardened steels: high hardness and heat resistance with low thermal conductivity. 	<p>DBQ</p>	<ul style="list-style-type: none"> ▲ AlCrN-Multilayer-Beschichtung ▲ Particularly suitable for machining stainless steels and titanium ▲ Low formation of built-up edges ▲ Maximum application temperature: > 1000 °C
<p>DBC</p>	<ul style="list-style-type: none"> ▲ Diamond-like carbon coating ▲ Specially for machining non-ferrous metals ▲ Maximum application temperature: 400 °C 	<p>DBF-A</p>	<ul style="list-style-type: none"> ▲ AlCrN Multilayer coating ▲ specially developed for the machining of tempered materials < 62 HRC ▲ maximum application temperature: > 1100 °C

Grade description – Reamers

DST

- ▲ Cermet, uncoated
- ▲ ISO | **P15** | **M10** | K10
- ▲ The uncoated cermet grade for finish machining stainless and hardened steel
- ▲ Particularly wear resistant thanks to high heat resistance

K10

- ▲ Carbide, uncoated
- ▲ ISO | **K10**
- ▲ Uncoated carbide grade for machining grey cast iron or non-ferrous metals, depending on the cutting edge geometry

CWC10

- ▲ Cermet, uncoated
- ▲ ISO | **P15** | **M10** | K10
- ▲ The uncoated cermet grade for finish machining of stainless and hardened steel
- ▲ Particularly wear-resistant due to high heat resistance

4

Grade description – Indexable insert countersink

BK8425

- ▲ Carbide, TiAlN/TiN-coated
- ▲ ISO | **P25** | **M25** | **K25**
- ▲ Universal grade with greater wear resistance thanks to innovative PVD multi-layer coating

K10

- ▲ Carbide, uncoated
- ▲ ISO | **K10**
- ▲ Uncoated carbide grade for machining grey cast iron or non-ferrous metals, depending on the cutting edge geometry

Chip breakers

-01

- ▲ Rake angle 12°
- ▲ All-round topography chamfered, rounded
- ▲ Very smooth-cutting thanks to positive cutting edge geometry
- ▲ Also suitable for less-powerful machines and unstable workpieces
- ▲ Easily controllable chip formation also in less solid materials

-G06

- ▲ Rake angle 6°
- ▲ For P / M / K materials
- ▲ High stability due to significant wedge angle

-U877

- ▲ Rake angle 6°
- ▲ circumferentially ground
- ▲ Three-ground chip breaker with second clearance angle for clearance with small tool diameters

-G12

- ▲ Rake angle 12°
- ▲ For P / N / S materials
- ▲ Extremely smooth-cutting thanks to positive cutting edge geometry
- ▲ Extremely suitable for less-powerful machines and unstable workpieces
- ▲ Easily controllable chip formation also in less solid materials

 Adapters which are ideal for reaming operations (such as the DAH compensation holder) can be found in the → **Clamping technology catalogue, Chapter 16**